

DYNAMO™ 1000

user's manual

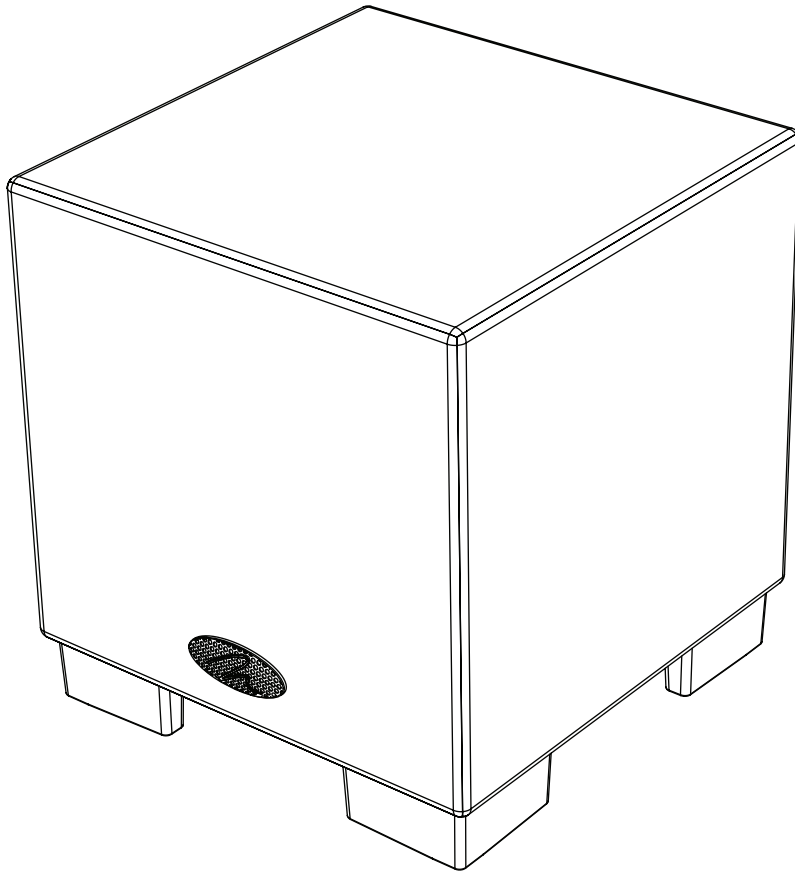

IMPORTANT SAFETY INSTRUCTIONS

- 1 Read these instructions.
- 2 Keep these instructions.
- 3 Heed all warnings.
- 4 Follow all instructions.
- 5 Do not use this apparatus near water.
- 6 Clean only with dry cloth.
- 7 Do not block any ventilation openings. Install in accordance with the manufacturer's instructions.
- 8 Do not install near any heat sources such as radiators, heat registers, stoves, or other apparatus (including amplifiers) that produce heat.
- 9 Do not defeat the safety purpose of the polarized or grounding-type plug. A polarized plug has two blades with one wider than the other. A grounding type plug has two blades and a third grounding prong. The wide blade or the third prong are provided for your safety. If the provided plug does not fit into your outlet, consult an electrician for replacement of the obsolete outlet.
- 10 Unplug this apparatus during lightning storms or when unused for long periods of time.
- 11 Refer all servicing to qualified service personnel. Servicing is required when the apparatus has been damaged in any way, such as power-cord or plug is damaged, liquid has been spilled or objects have fallen into the apparatus, the apparatus has been exposed to rain or moisture, does not operate normally, or has been dropped.
- 12 The mains plug of the power supply cord shall remain readily operable.
- 13 To completely disconnect this equipment from the mains, disconnect the power supply cord plug from the receptacle.
- 14 Protect the power cord from being walked on or pinched particularly at plugs, convenience receptacles, and the point where they exit from the apparatus.
- 15 Only use attachments/accessories specified by the manufacturer.
- 16 Use only with the cart, stand, tripod, bracket, or table specified by the manufacturer, or sold with the apparatus. When a cart is used use caution when moving the cart/apparatus combination to avoid injury from tip-over.
- 17 **WARNING:** To reduce the risk of fire or electric shock, this apparatus should not be exposed to rain or moisture and objects filled with liquids, such as vases, should not be placed on this apparatus.

Serial Numbers: _____

Record your serial numbers here for easy reference. You will need this information when filling out your warranty registration. Dynamo 1000's serial number is located near the bottom of the backplate and on the shipping container.



This device complies with part 15 of the FCC Rules. Operation is subject to the following two conditions: (1) This device may not cause harmful interference, and (2) this device must accept any interference received, including interference that may cause undesired operation.

Dynamo 1000
 Tested to Comply with FCC Standards
FC
 FOR HOME OR OFFICE USE



WARNING!

- Hazardous voltages exist inside—do not remove cover.
- Refer servicing to a qualified technician.
- To prevent fire or shock hazard, do not expose this module to moisture.
- Unplug subwoofer should any abnormal conditions occur.



In accordance with the European Union WEEE (Waste Electrical and Electronic Equipment) directive effective August 13, 2005, we would like to notify you that this product may contain regulated materials which upon disposal, according to the WEEE directive, require special reuse and recycling processing.

For this reason MartinLogan has arranged with our distributors in European Union member nations to collect and recycle this product at no cost to you. To find your local distributor please contact the dealer from whom you purchased this product, email info@martinlogan.com or visit the distributor locator at www.martinlogan.com.

Please note, only this product itself falls under the WEEE directive. When disposing of packaging and other related shipping materials we encourage you to recycle these items through the normal channels.



The lightning bolt flash with arrowhead symbol, within an equilateral triangle, is intended to alert the user to the presence of uninsulated "dangerous voltage" within the product's enclosure that may be of sufficient magnitude to constitute a risk of electric shock.

Important Safety Instructions 2
Contents 3
Packaging 4
Introduction 5
Installation in Brief. 6
About the Controls 7
Connections and Control Settings 8
 Before Connecting the Dynamo 1000
 2-Channel Mode
 Multi-Channel/LFE Mode. 9
 AC Power Connection 10
 Replacing the Fuse
 Break-In
 Optional Wireless Connection
Placement 11
 Listening Position
 Ask Your Dealer
 Enjoy Yourself
 Installing in a Cabinet
 Changing Woofer Orientation 12
Room Acoustics 13
 Your Room
 Terminology
 Solid Footing
Home Theater 14
FAQ & Troubleshooting 15
 FAQ
 Troubleshooting
General Information 16
 Specifications
 Warranty and Registration
 Service
Dimensional Drawings 17
Glossary of Audio Terms 18



The exclamation point within an equilateral triangle is intended to alert the user to the presence of important operating and maintenance (servicing) instructions in the literature accompanying the appliance.



WARNING! Do not use your Dynamo 1000 loudspeakers outside of the country of original sale—voltage requirements vary by country. Improper voltage can cause damage that will be potentially expensive to repair. The Dynamo 1000 is shipped to authorized MartinLogan distributors with the correct power supply for use in the country of intended sale. A list of authorized distributors can be accessed at www.martinlogan.com or by emailing info@martinlogan.com.

PACKAGING

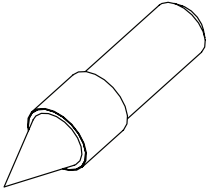
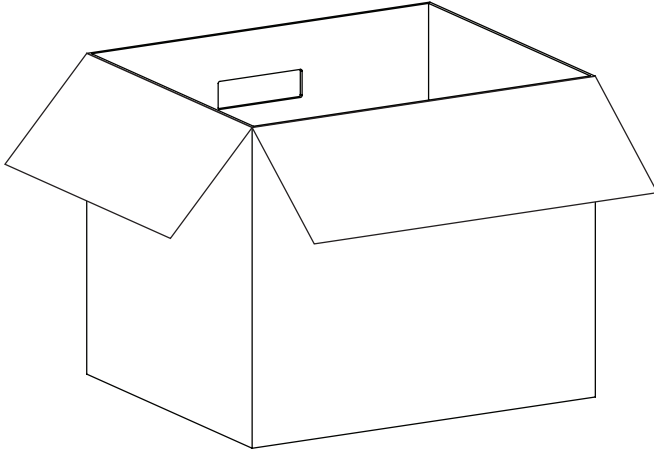
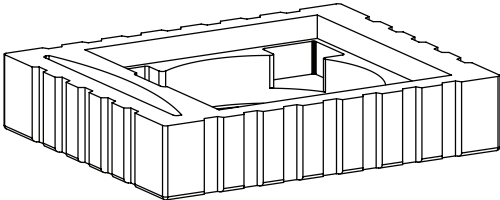
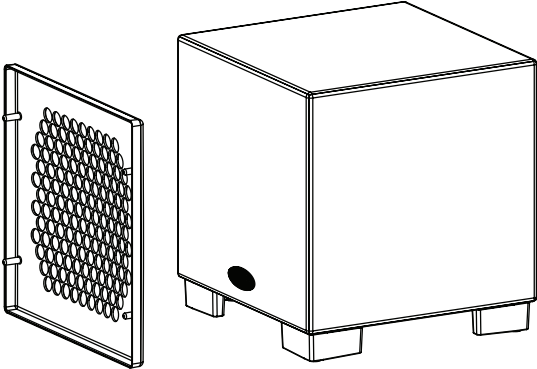
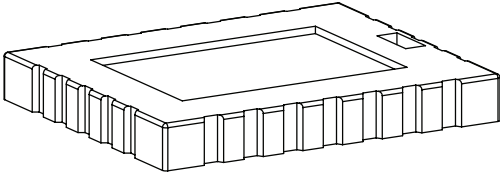

x 4

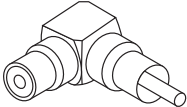

x 2

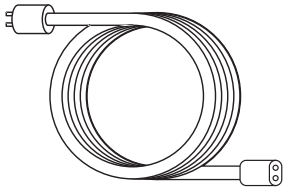

x 1

Thank you—the MartinLogan owner,
for loving what we do,
and
making it possible for us to do what we love.

Congratulations! You have invested in one of the world's premier subwoofers.

The MartinLogan Dynamo 1000 represents the extension of an intensive, dedicated team research program directed toward establishing a world class line of reference subwoofers using leading-edge technology, without compromising durability, reliability, craftsmanship or aesthetics.

The Dynamo 1000 subwoofer uses a 12-inch high-excursion driver to achieve deep, tight, well-defined bass. A proprietary amplifier is used to drive the output stage with precision and extremely high efficiency. Low-pass filtering and phase control have been designed to make integrating the Dynamo 1000 subwoofer with MartinLogan and non-MartinLogan products both seamless and simple.

The materials in your new Dynamo 1000 subwoofer are of the highest quality and will provide years of enduring enjoyment and deepening respect. The cabinet is constructed from the finest composite material for acoustical integrity and is finished with an attractive custom coating.

This User's Manual will explain in detail the operation of your Dynamo 1000 subwoofer and the philosophy applied to its design. A clear understanding will insure that you obtain maximum performance and pleasure from this most exacting subwoofer.

INSTALLATION IN BRIEF

We know that you are eager to hear your new Dynamo 1000 subwoofer, so this section is provided to allow fast and easy set up. Once you have it operational, please take the time to read, in depth, the rest of the information in this manual. It will give you perspective on how to attain the greatest possible performance from this most exacting subwoofer system.

If you experience any difficulties in setup or operation of the Dynamo 1000, please refer to the Placement, Room Acoustics and Connections and Control Settings sections.

Should you encounter a persistent problem that cannot be resolved, please contact your authorized MartinLogan dealer. They will provide you with the appropriate technical analysis to alleviate the situation.

Step 1: Unpacking

Remove your new subwoofer from its packing.

Step 2: Placement

Ideally, place the Dynamo 1000 in a corner near the front of the room. This is a good place to start. Please see the Placement section (page 11) of this manual for more details.

Step 3: Signal Connection

Use the best cables you can. High quality cables, available from your specialty dealer, are recommended and will give you superior performance.

Attach your preamplifier/processor outputs through cables to the signal input area located on the Dynamo 1000's rear panel. Please see the Connections and Control Settings section (pages 8–10) of this manual for more details.

Step 4: Power Connection (AC) (see warning)

Make sure the level knob is set at 'Min'. Plug the Dynamo 1000 subwoofer into a wall outlet. Review the AC Power Connection section (page 10) of this manual for more details.

Step 5: Setting the Controls

Set the level knob to a medium volume position (12 o'clock). Set the power switch to 'Auto On'.

Step 6: Listen and Enjoy

Now, you may adjust your system and enjoy!

ABOUT THE CONTROLS

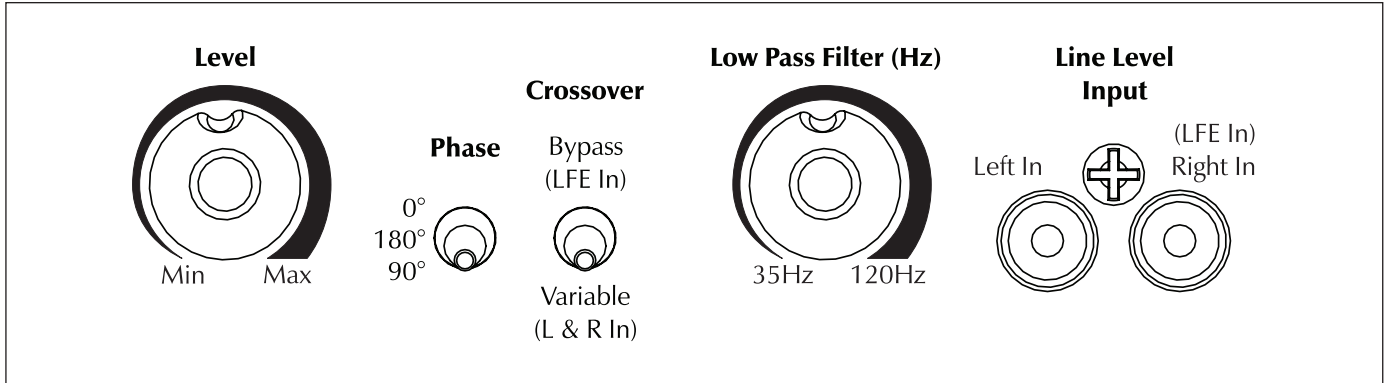

Figure 1. Dynamo 1000 controls.

Level Knob

Setting the level too high will cause the bass to seem bloated and is the single most common cause of bad sounding subwoofers. A rule of thumb is that the subwoofer should not draw attention to itself, but should simply make the systems low end seem more extended and accurate.

Phase Control Switch

The phase control is entirely dependent on the size and configuration of your listening environment, the placement of the unit, and your seating arrangement. Due to the way bass sound waves develop in different rooms, there is no rule of thumb for setting phase. For instance, if your room has a peak at the subwoofer crossover area, you may wish to set the phase so the actual acoustic outputs of the subwoofer and main speakers are out of phase. Experiment, try different settings and be patient.

Crossover

When the Dynamo 1000 is connected in multi-channel mode (via its Right/LFE input), the crossover switch should be set to 'Bypass (LFE In)' so that the low pass filter is not active and your processor handles the bass management.

When connected in 2-channel mode (via its line level left/right input), the crossover switch should be set to 'Variable (L&R In)' so that the low-pass filter is active.

Low Pass Filter Knob

When the Dynamo 1000 is connected in multi-channel mode (via its LFE input), the low pass filter is not active

and your processor handles the bass management. When connected in 2-channel mode via its line level left/right input, the low-pass filter is active.

As a general rule the low pass filter should be set equal to approximately 70% of your speaker's lowest frequency response. Remember, this is a general rule. We advise that once you try the recommended setting using the formula above, you should try the surrounding settings to see which sounds best.

Wireless Sync Button and Status LED (not shown above)

The wireless sync button is used to establish connection to the optional SWT-1 MartinLogan Subwoofer Wireless Transmitter (sold separately and available from your authorized dealer or the Xtatic shop at www.MartinLogan.com). The Wireless status LED indicates the current status of the wireless connection (see page 10 for further details).

Status LED (not shown above)

When the status LED (located on the back of the subwoofer) is blue, the subwoofer is on. When the status LED is red the subwoofer is in standby mode.

Master Power Switch (not shown above)

Located on the back panel of the subwoofer, the Master Power switch must be set to 'Auto On' for the subwoofer to operate. When set to 'Auto On' the subwoofer will automatically enter a power saving mode when no audio signal is detected. The subwoofer will automatically come out of power saving mode when a signal is detected.

CONNECTIONS AND CONTROL SETTINGS

Before Connecting the Dynamo

MartinLogan's engineering and design team developed the Dynamo 1000 for easy setup and system integration. Before beginning to connect your Dynamo 1000, please review the controls discussed in the last section. An understanding of these will help speed you along as you connect and integrate your Dynamo 1000 with your system. All signal connections are done on the rear connections panel of the Dynamo 1000. Make certain that all of your connections are tight.



WARNING! Turn your Dynamo 1000 subwoofer to 'Off' before making or breaking any signal connections!

2-Channel Mode

This setup is recommended if your Dynamo 1000 will be used in a 2-channel system with main speakers playing full range. When a signal is connected to the Dynamo 1000's left/right inputs and the crossover switch is set to 'Variable (L&R In)', the Dynamo 1000's internal low pass filter is active.

If you will be using your system for both 2-channel and multi-channel listening we recommend connecting the Dynamo 1000 as recommended in 'Multi-Channel/LFE Mode' on the next page. Some modern receivers and processors allow users to route left and right channel low-frequency information, in addition to discrete LFE information, through the LFE output.

Signal Connection (see figure 2):

- 1 Connect the left and right outputs of your preamplifier to the left and right inputs of the Dynamo 1000 using quality RCA interconnects. If your preamplifier only has one set of outputs you may need to obtain Y adapters from your dealer.

Recommended Control Settings (see figure 3):

- 1 Set the crossover switch to 'Variable (L&R In)'.
- 2 Set the 'Low Pass Filter' knob to approximately 70% of your loudspeakers lowest frequency response.

- 3 While playing music with bass content, turn the level control up until the music has deep extended bass, being careful to avoid levels that become overwhelming.
- 4 Try the phase control in different settings until the best blending is obtained. If you are augmenting MartinLogan loudspeakers, we suggest you start with the phase set at 90°.

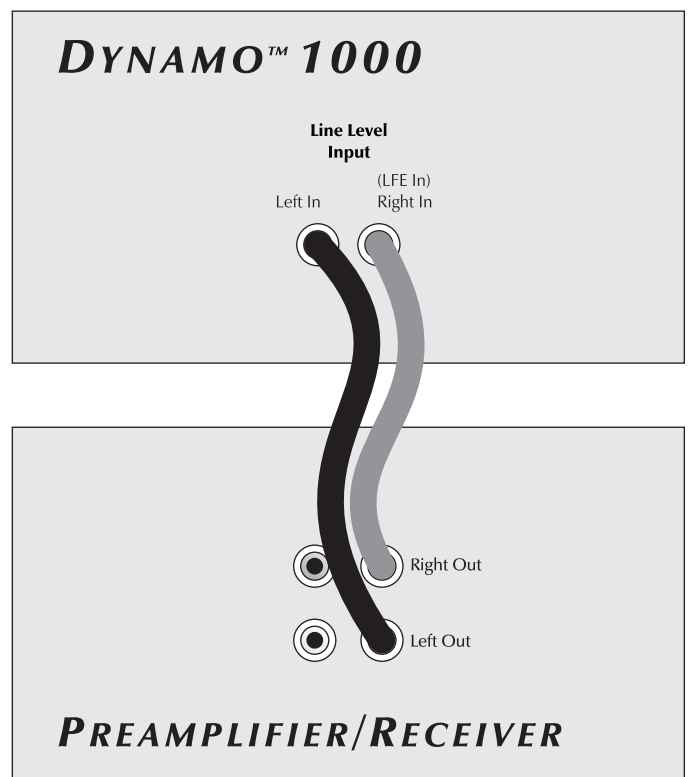

Figure 2. Signal connection for 2-channel mode.

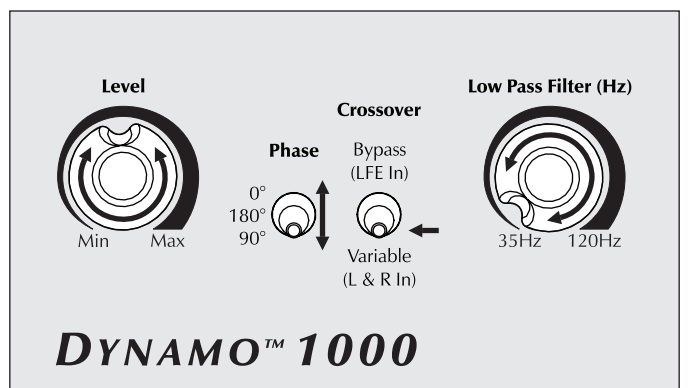

Figure 3. Control settings for 2-channel mode.

Multi-Channel/LFE Mode

This setup is recommended if your Dynamo 1000 will be used in a dedicated home theater or multi-channel system. When a signal is connected to the subwoofer's LFE input, and the crossover switch is set to 'Bypass (LFE In)' the internal low pass filter is not active. By following this setup, you will allow your processor to handle most of the bass management.

If you will be using your system for both 2-channel and multi-channel listening we recommend using this setup and connection method. Some modern receivers and processors allow users to route left and right channel low-frequency information, in addition to discrete LFE information, through the LFE output.

Signal Connection (see figure 4):

- 1 Connect the LFE output of the processor to the LFE input using a quality RCA interconnect.



WARNING!

Based on the performance of most processors, it is recommended that MartinLogan center and effects type speakers (i.e. Motif, Matinee, Stage, etc.) not be run in large, wide, or full range mode. Doing so may potentially damage the speaker if the processor attempts to drive the speaker beyond its rated frequency range. This warning also applies to products from other manufacturers.

It is recommended to run center and effects type speakers in limited or narrow mode. Some processors have an option to route the LFE channel to your main and/or surround speakers. We recommend that you do not use this option.

Recommended Control Settings (see figure 5):

- 1 Set the crossover switch to 'Bypass (LFE In)'.
- 2 Use the bass management section of your processor's speaker level setup option to set the subwoofer level at an appropriate level. Follow the instructions in your processor manual to fine-tune the subwoofer level.
- 3 If your processor offers the option to setup crossovers for a subwoofer, we recommend that you start with the following settings—Crossover: 70Hz, High-Pass: 12dB, and Low-

Pass: 24dB. The optimal setting for these options may vary depending on your room and listening preferences.

- 4 Adjust the phase control until ideal blending is obtained. If you hear no discernible difference leave the phase at 0°.
- 5 Follow the instructions in your processor manual to fine-tune the subwoofer level

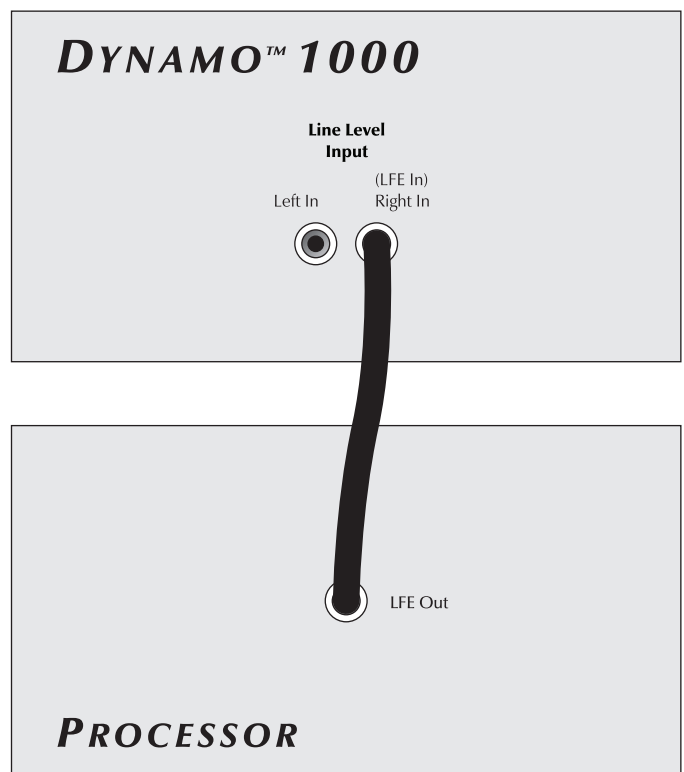

Figure 4. Signal connection for multi-channel mode.

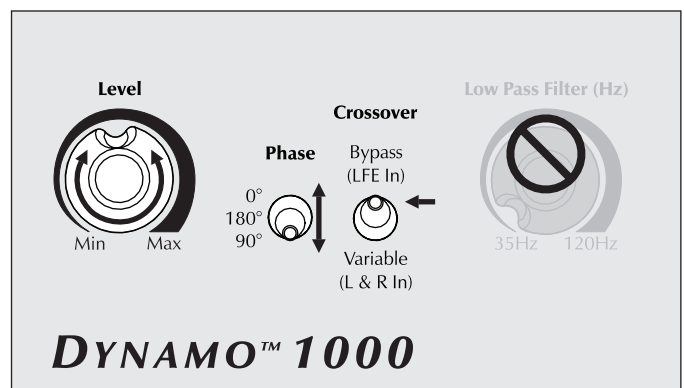

Figure 5. Control settings for multi-channel mode.

AC Power Connection



WARNING! The power cord should not be installed, removed, or left detached from the subwoofer while the other end is connected to an AC power source.

The IEC power cord should be firmly inserted into the AC power receptacle on the rear connection panel of the Dynamo, then to any convenient AC wall outlet. The Dynamo also integrates a signal sensing power supply that automatically switches off after sensing no music signal for several minutes (this will occur when the power switch is set to 'Auto').

Your Dynamo subwoofer is wired for the power service supplied in the country of original consumer sale. The AC power rating applicable to a particular unit is specified both on the packing carton and on the serial number plate attached to the subwoofer.

If you remove your Dynamo subwoofer from the country of original sale, be certain that AC power supplied in any subsequent location is suitable before connecting and operating the subwoofer. Substantially impaired performance or severe damage may occur to the Dynamo subwoofer if operation is attempted from an incorrect AC power source.

Replacing the Fuse

If the fuse in your Dynamo 1000 should require changing, turn off and unplug your Dynamo 1000 before removing the fuse. Replace the bad fuse with a matching T 5A L 250V (T 2.5A L 250V if you are in a region using 230V).

Break-In

Our custom made woofers require approximately 50 hours of break-in at moderate listening levels before their optimal performance occurs. This will factor in on any critical listening and judgment.

Optional Wireless Connection

The Dynamo 1000 incorporates a wireless receiver for use with the MartinLogan SWT-1 Subwoofer Wireless Transmitter (sold separately and available from your authorized dealer or the Xtatic shop at www.MartinLogan.com). To establish a wireless connection, connect a transmitter to your electronics and follow these two easy steps.

1. Press the Dynamo 1000's sync button once. The LED will blink quickly.
2. Press the sync button on the SWT-1 transmitter once. The LED will blink quickly. If pairing has completed successfully both LEDs will stop blinking and remain on. **Please note:** If a link is not established after 10 seconds this transmitter's LED will start blinking slowly. Repeat both steps.

WARNING! When operating wirelessly this subwoofer may be susceptible to RF interference in the 2.4GHz bandwidth from microwave ovens and wireless devices such as WiFi systems, video game consoles, cordless telephones, blue tooth devices, and baby monitors. Generally, this issue (popping noises) is easily resolved by physically separating problematic devices from one another—a distance as little as two feet will often alleviate the interference. In the case of microwave ovens, the interference will only occur when the microwave is operating.

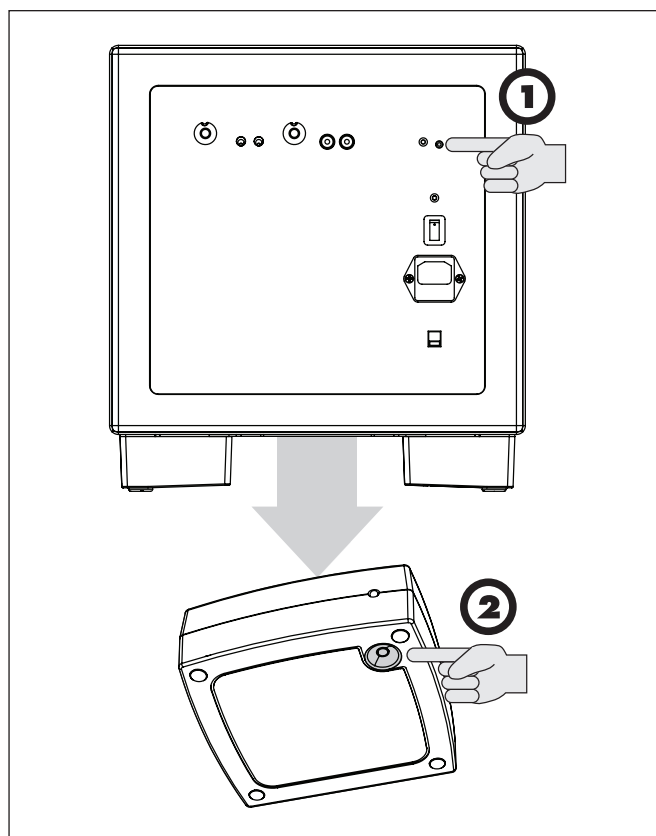

Figure 6. Establishing a connection between the Dynamo 1000 and the SWT-1 Subwoofer Wireless Transmitter (sold separately).

Listening Position

Generally, subwoofers have the most output when placed in the corner of a room. However, this can also exaggerate the subwoofers output making blending difficult. We recommend starting by placing the Dynamo 1000 in a corner. If, after the full range of tuning techniques have been employed, the subwoofer sounds like it has too much upper bass energy try pulling it away from the wall, toward the listening position. This will lessen the reinforcement of these problematic frequencies from the wall and likely smooth out the response. Repeat the tuning techniques with the woofer controls after you move it (see figure 7).

Ask Your Dealer

Your MartinLogan dealer can suggest many options for optimal subwoofer placement. They also have many tools at their disposal, such as experience, familiarity with the associated equipment, and even sound analysis equipment which may make the task of determining optimal subwoofer placement easier.

Enjoy Yourself

The Dynamo 1000 is a very refined subwoofer and will benefit from care in setup. With the above placement tips in mind you will find, over months of listening, that small changes can result in measurable differences. As you live with your subwoofer, do not be afraid to experiment with positioning until you find the optimal relationship between your room, settings and subwoofer that gives you the best results. Your efforts will be rewarded.

Installing in a Cabinet

When placing the Dynamo 1000 inside of a cabinet it is recommended that there be a minimum of three inches of open space between the cabinet and the front and back sides (see figure 8).

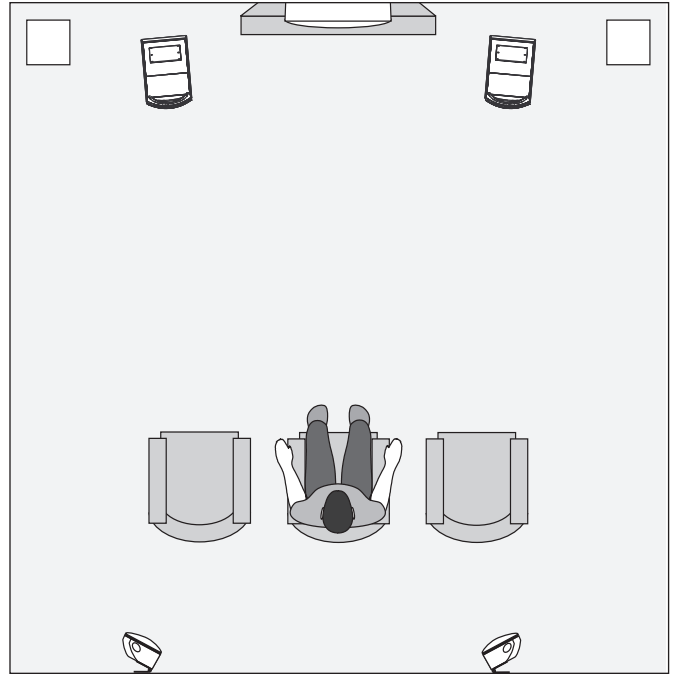

Figure 7. Dynamo 1000 Subwoofers as the LFE (effects) channels, MartinLogan Source™ speakers as front channels, and Fresco™ speakers as surround (effects) and center channels. Note the corner placement of the Dynamo 1000 at the front of the listening room.

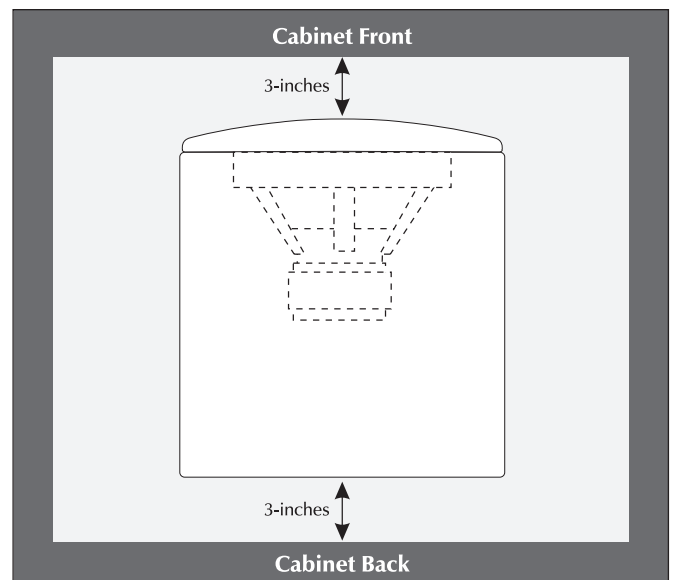

Figure 8. Placing the Dynamo 1000 in a cabinet requires a minimum of three inches of open space on the front and back.

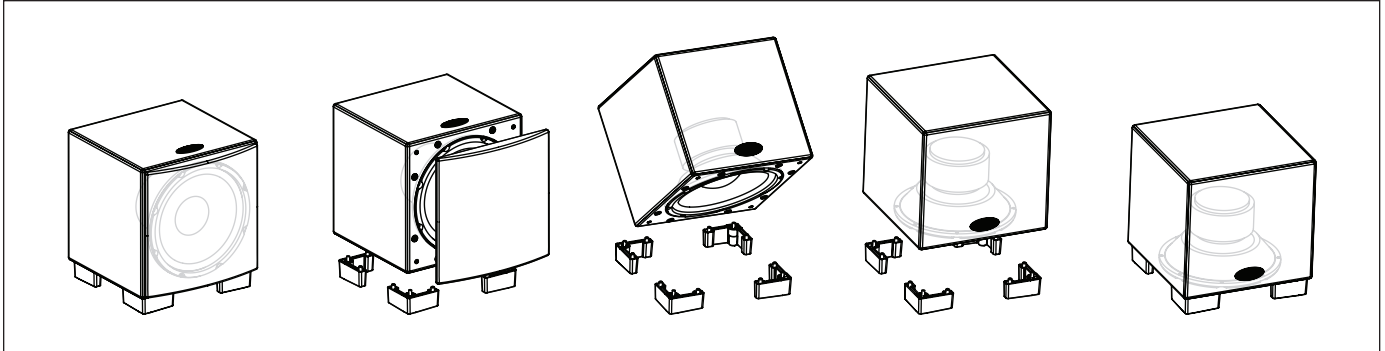

Figure 9. The Dynamo 1000 is capable of both front-firing and down-firing woofer orientations.

Changing Woofer Orientation

When installing the Dynamo 1000 in a cabinet it is recommended that the subwoofer be converted to a front firing configuration. (see figure 9).

- 1 Prepare a flat surface with a blanket to protect the Dynamo 1000's finish. Unplug signal and power connections. Remove the grill cloth.
- 2 Carefully lay the Dynamo 1000 on its side. Using a coin, unscrew the attached feet. (see figure 10).
- 3 Change the location of the four feet.
- 4 Using a coin, reinstall the feet (see figure 10).

Please note, 90° RCA adaptors may be required to make signal connections. Two 90° RCA adaptors are included with the Dynamo 1000 subwoofer.

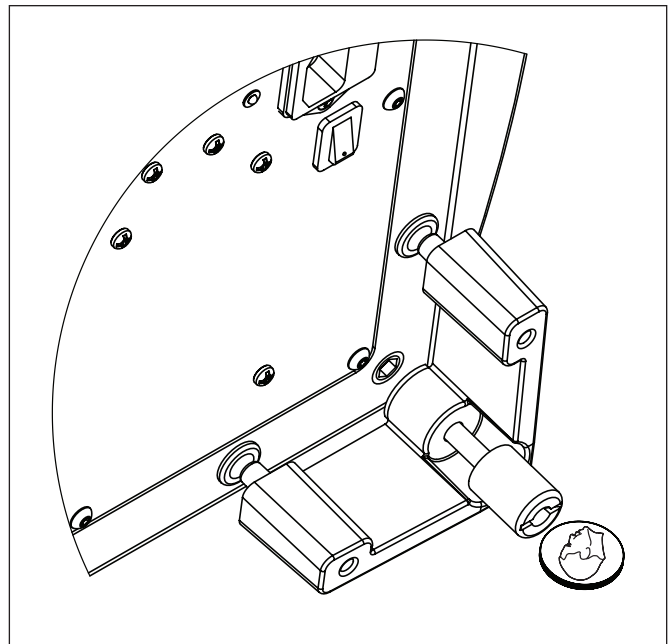

Figure 10. To change woofer orientation, use a coin to unscrew the attached feet, change location, and reinstall.

Your Room

This is an area that requires both a little background to understand and some time and experimentation to attain the best performance from your system. Your room is actually a component and an important part of your system. This component is a large variable and can dramatically add to or subtract from a great sonic experience.

All sound is composed of waves. Each frequency has its own wave size, with the lower, or bass frequencies literally encompassing from 10 feet to as much as 40 feet. Your room participates in this wave experience like a swimming pool with waves reflecting and becoming enhanced depending on the size and shape of the room and the types of surfaces in the room.

Remember that your audio system can actually generate all of the information required to recreate a sonic event in time, space, and tonal balance. Acoustically, the role of an ideal room would be to neither delete nor contribute to that information. However, nearly every room does to some degree.

Terminology

Standing Waves

Sound coming from a speaker bounces around in a room until a pattern emerges—this is called a standing wave. Typically, this is only a problem with frequencies below 100Hz. When this happens different parts of your room experience either an excess or a lack of bass.

Some people believe that having a room without parallel walls will eliminate this effect. The truth is that non-parallel walls only generate different standing wave patterns than those that occur in rectangular rooms.

Usually, you can excite most of the standing waves in a room by putting the Dynamo 1000 in a corner. Listening position determines which standing waves you will experience. For instance, if you sit in a corner you will hear most of the standing waves. This can be an overpowering experience. Sitting next to a wall can also intensify the levels of the standing waves that are experienced.

Resonant Surfaces and Objects

All of the surfaces and objects in your room are subject to the frequencies generated by your system. Much like an instrument, they will vibrate and "carry on" in syncopation

with the music, and may contribute in a negative way to the sound. Ringing, boominess, and even brightness can occur simply because surfaces and objects are "singing along" with your speakers.

Resonant Cavities

Small alcoves or closet type areas in your room can be chambers that create their own "standing waves" and can drum their own "one note" sounds.

Solid Footing

After living and experimenting with your Dynamo 1000, you may want to use ETC™ (Energy Transfer Coupler) Spikes (see figure 11). With the use of these spikes, the Dynamo 1000 will become more firmly planted on the floor and, consequently, bass will tighten. It is best not to implement the spikes, however, until you are secure in the positioning, as the spikes can damage the floor if the subwoofer is moved.

Spike Installation Instructions:

- 1 Carefully lay the Dynamo 1000 on its side to gain access to the bottom of the feet.
- 2 Firmly press the spikes into the feet of the Dynamo 1000.

Caution: Make sure your hands and any cabling are clear of the spikes. Do not slide the subwoofer as spikes are sharp and can damage your floor or carpet.

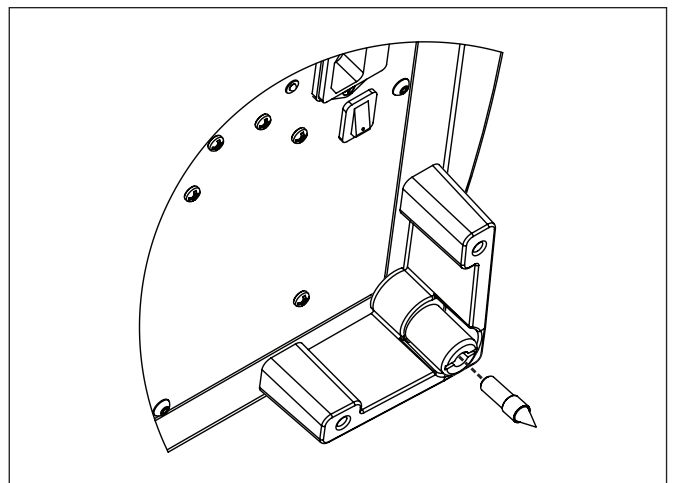

Figure 11. To install the spikes, press them into the feet.

HOME THEATER

It had long been the practice of stereo buffs to connect their television to a stereo system. The advantage was the use of the larger speakers and more powerful amplifier of the stereo system. Even though the sound was greatly improved, it was still mono and limited by the broadcast signal.

In the late 1970's and early 1980's two new home movie formats became widely available to the public: VCR and laser disc.

By 1985, both formats had developed into very high quality audio/video sources. In fact, the sonic performance of some video formats exceeded audio-only formats. Now, with theater-quality sound available at home, the only element missing was the "surround sound" presentation found in movie houses.

Fortunately, Dolby and DTS encoded DVD's emerged with the same surround sound information encoded on home releases as the theatrical release. Additionally, new high-resolution home-viewing formats such as Blu-ray as well as high-definition content provided via cable or satellite have evolved which include multi-channel encoded audio that is virtually master tape quality. All that is required to retrieve this information is a decoder and additional speakers and amps to reproduce it.

Home theater is a complex purchase and we recommend that you consult your local MartinLogan dealer, as they are well versed in this subject.

Each piece of a surround system can be purchased separately. Take your time and buy quality. No one has ever complained that the movie was too real. The following list and descriptions will give you only a brief outline of the responsibilities and demands placed on each speaker.

Front Left and Front Right

If these speakers will be the same two used for your stereo playback, they should be of very high quality and able to play loudly (over 102 dB) and reproduce bass below 80 Hz.

Center Channel

This is the most important speaker in a home theater system, as almost all of the dialogue and a large portion of the front speaker information is reproduced by the center speaker. It is important that the center speaker be extremely accurate and mate well with the front

speaker, and that it is recommended for use as a center speaker. This is not the place to cut corners.

Surround Speakers

We recommend (along with the film industry) that the surround speakers play down to at least 80 Hz. Surround speakers contain the information that makes it appear that planes are flying over your head. Some may suggest that this is the place to save money and purchase small, inexpensive speakers. If you choose to do so, be prepared to upgrade in the future as discrete multi-channel digital encoding is proliferating rapidly and the demands on surround speakers have increased.

Subwoofer

With any good surround system you will need one or more high-quality subwoofers (the .1 in a 5.1, 6.1, or 7.1 channel surround system). Most movie soundtracks contain large amounts of bass information as part of the special effects. Good subwoofers will provide a foundation for the rest of the system.

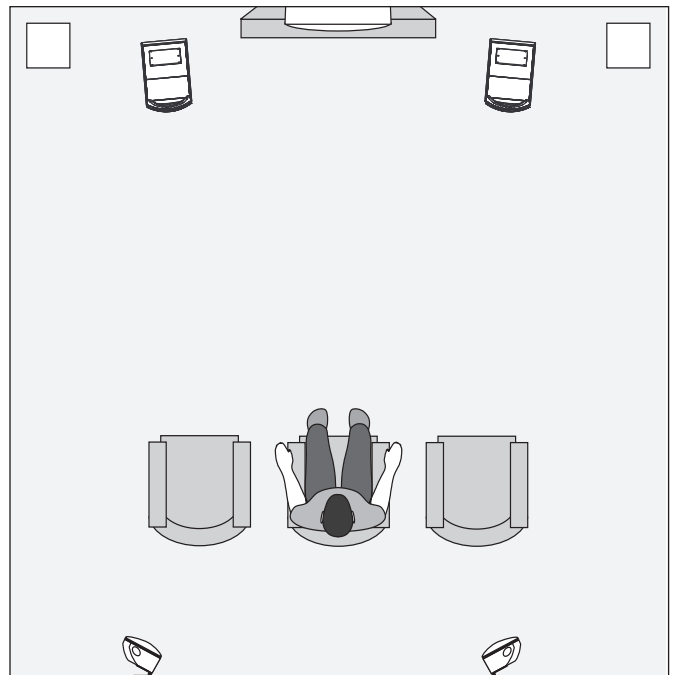

Figure 12. Dynamo 1000 Subwoofers as the LFE (effects) channels, MartinLogan Source speakers as front and surround (effects) channels, MartinLogan Fresco as the center channel.

FREQUENTLY ASKED QUESTIONS & TROUBLESHOOTING

Frequently Asked Questions

How do I clean my subwoofer?

Use a dust free cloth or a soft brush to clean your subwoofer. We recommend a specialty cloth (available through the Xtatic shop at www.martinlogan.com) that cleans better than anything else we have tried.

Is it safe to set things on my subwoofer?

While your Dynamo 1000 is designed with a durable, stain-resistant surface, we advise you not to set anything on your Dynamo 1000—especially containers holding liquids.

Is there likely to be any interaction between my subwoofer and the television in my Audio/Video system?

Yes. The Dynamo 1000 subwoofer doesn't use a shielded driver. We recommend 3 feet between the Dynamo 1000 subwoofer and video components that are susceptible to magnetic fields.

Is there likely to be any interaction between my subwoofer and other electrical devices in my house?

Yes. When operating wirelessly this subwoofer may be susceptible to RF interference in the 2.4GHz bandwidth from microwave ovens and wireless devices such as WiFi systems, video game consoles, cordless telephones, blue tooth devices, and baby monitors. Generally, this issue (popping noises) is easily resolved by physically separating problematic devices from one another—a distance as little as two feet will often alleviate the interference. In the case of microwave ovens, the interference will only occur when the microwave is operating.

Will my electric bill go 'sky high' by leaving my subwoofer plugged in all the time?

No. The Dynamo 1000, when the power switch is set to 'Auto On', will draw about 15 watts when idle and only 1 watt in standby mode.

Should I unplug my subwoofer during a thunderstorm?

Yes, or before. It's a good idea to disconnect all of your audio/video components during stormy weather.

Troubleshooting

No Output

- Check that all your system components are turned on.
- Check that the master power switch adjacent to the AC receptacle is set to 'Auto On'.
- Check your wires and connections.
- Check all interconnecting cables.
- Make sure the level control is not turned down.
- Turn off and unplug the Dynamo 1000 and check the fuse near the AC power cord receptacle on the back. If the fuse has blown, replace the bad fuse with a matching T 5A L 250V fuse (T 2.5A L 250V if you are in a region using 230V).
- If the problem persists, contact your dealer.

Muddy Bass

- Check placement. Try moving the subwoofer closer to the front and side walls.
- Check the type of feet that are being used. Try installing the ETC spikes.
- Decrease the level.
- Check your processor setup.
- If the problem persists, contact your dealer.

Hums or Unusual Sounds

- Turn the Dynamo 1000 off, unplug all signal inputs, turn the Dynamo 1000 back on and turn up the level. If the problem disappears, the hum is originating elsewhere in your system.
- Connect the Dynamo 1000's AC connection to the same AC circuit as the pre amp.
- If operating in wireless mode, move the subwoofer away from microwave ovens and/or any devices that use wireless technology.
- If the problem persists, contact your dealer.

GENERAL INFORMATION

Specifications

The Dynamo 1000 subwoofer system consists of a single woofer for high SPL output with minimal distortion. The equalization used is specifically designed to counteract the response of the woofers sealed box response. This equalization leads to minimal group delay and proper transient response.

System Frequency Response

22–200 Hz \pm 3 dB. Anechoic in LFE mode.

Low Pass Filter Frequencies

35Hz–120Hz

Low Pass Filter Switch

Bypass (LFE In), Variable (L&R In)

Phase

0°, 90°, 180°

Components

12" (30.5cm) high-excursion, polypropylene cone with extended throw driver assembly; sealed non-resonant cabinet design

Amplifier

500 watts RMS (1000 watts peak)

Impedance

Left & Right/LFE RCA – 20,000 Ohms

Inputs

Left & Right/LFE RCA Line Level

Weight

34 lbs. each (15.4 kg)

Mains Power Draw

Standby: 1W

Idle: 15W

Max: 650W

Size (Front-Firing Orientation)

13.69 inches W x 14.35 inches D x 15.46 inches H
(34.8cm W x 36.4cm D x 39.3cm H)

Size (Down-Firing Orientation)

13.69 inches W x 14.59 inches D x 14.54 inches H
(34.8cm W x 37.1cm D x 14.54cm H)

Warranty and Registration

Your Dynamo 1000 subwoofer is provided with an automatic Limited 90 Day Warranty coverage.

You have the option, at no additional charge, to receive Limited 3-Year Warranty coverage. To obtain the Limited 3-Year Warranty coverage you need to complete and return the Certificate of Registration, included with your subwoofer, and provide a copy of your dealer receipt, to MartinLogan within 30 days of purchase.

For your convenience MartinLogan also offers online warranty registration at www.martinlogan.com.

MartinLogan may not honor warranty service claims unless we have a completed Warranty Registration card on file!

If you did not receive a Certificate of Registration with your new Dynamo 1000 subwoofer you cannot be assured of having received a new unit. If this is the case, please contact your authorized MartinLogan dealer.

Service

Should you be using your MartinLogan product in a country other than the one in which it was originally purchased, we ask that you note the following:

- 1 The appointed MartinLogan distributor for any given country is responsible for warranty servicing only on units distributed by or through it in that country in accordance with its applicable warranty.
- 2 Should a MartinLogan product require servicing in a country other than the one in which it was originally purchased, the end user may seek to have repairs performed by the nearest MartinLogan distributor, subject to that distributor's local servicing policies, but all cost of repairs (parts, labor, transportation) must be born by the owner of the MartinLogan product.
- 3 If, after owning your subwoofer for six months, you relocate to a country other than the one in which you purchased your subwoofer, your warranty may be transferable. Contact MartinLogan for details.

DIMENSIONAL DRAWINGS

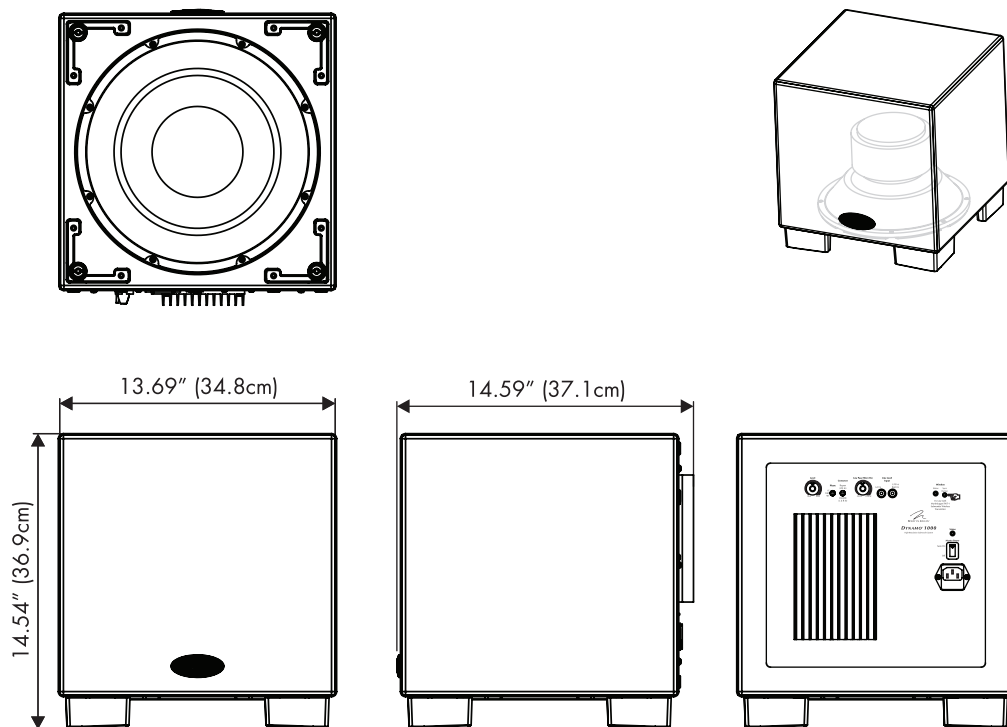
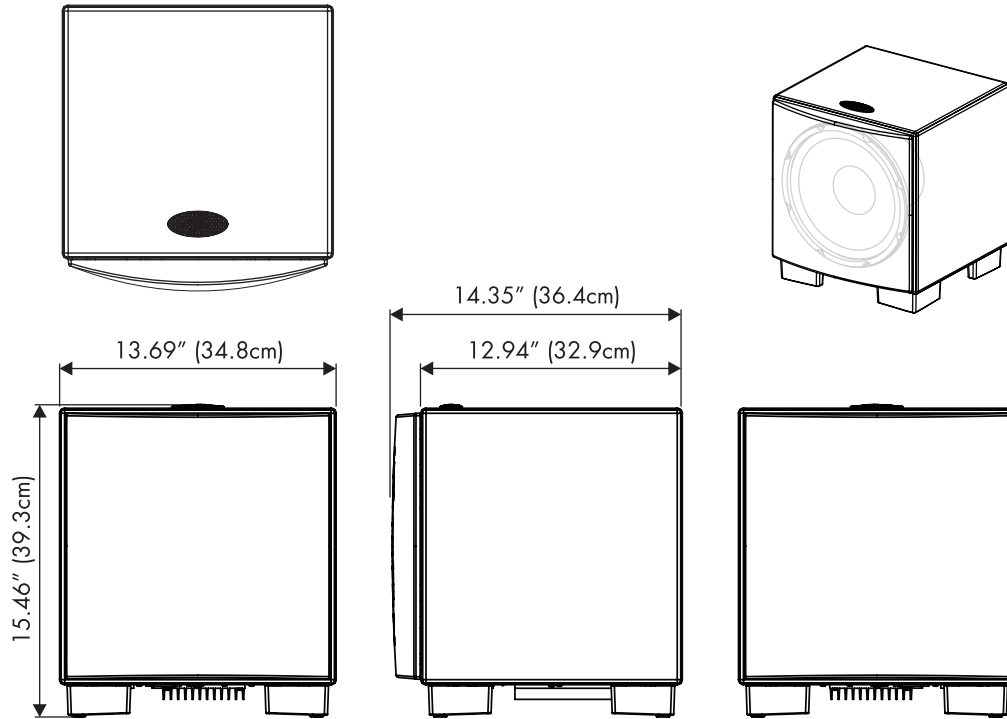

GLOSSARY OF AUDIO TERMS

AC. Abbreviation for alternating current.

Active crossover. Uses active devices (transistors, ICs, tubes) and some form of power supply to operate.

Amplitude. The extreme range of a signal. Usually measured from the average to the extreme.

Arc. The visible sparks generated by an electrical discharge.

ATF. The abbreviation for advanced thin film.

Bass. The lowest frequencies of sound.

Bi-Amplification. Uses an electronic crossover, or line-level passive crossover, and separate power amplifiers for the high and low frequency loudspeaker drivers.

Capacitance. That property of a capacitor which determines how much charge can be stored in it for a given potential difference between its terminals, measured in farads, by the ratio of the charge stored to the potential difference.

Capacitor. A device consisting of two or more conducting plates separated from one another by an insulating material and used for storing an electrical charge. Sometimes called a condenser.

Clipping. Distortion of a signal by its being chopped off. An overload problem caused by pushing an amplifier beyond its capabilities. The flat-topped signal has high levels of harmonic distortion which creates heat in a loudspeaker and is the major cause of loudspeaker component failure.

CLS. The abbreviation for curvilinear line source.

Crossover. An electrical circuit that divides a full bandwidth signal into the desired frequency bands for the loudspeaker components.

dB (decibel). A numerical expression of the relative loudness of a sound. The difference in decibels between two sounds is ten times the Base 10 logarithm of the ratio of their power levels.

DC. Abbreviation for direct current.

Diffraction. The breaking up of a sound wave caused by some type of mechanical interference such as a cabinet edge, grill frame or other similar object.

Diaphragm. A thin flexible membrane or cone that vibrates in response to electrical signals to produce sound waves.

Distortion. Usually referred to in terms of total harmonic distortion (THD) which is the percentage of unwanted harmonics of the drive signal present with the wanted signal. Generally used to mean any unwanted change introduced by the device under question.

Driver. See transducer.

Dynamic Range. The range between the quietest and the loudest sounds a device can handle (often quoted in dB).

Efficiency. The acoustic power delivered for a given electrical input. Often expressed as decibels/watt/meter (dB/w/m).

ESL. The abbreviation for electrostatic loudspeaker.

Headroom. The difference, in decibels, between the peak and RMS levels in program material.

Hybrid. A product created by the marriage of two different technologies. Meant here as the combination of a dynamic woofer with an electrostatic or ATF transducer.

Hz (Hertz). Unit of frequency equivalent to the number of cycles per second.

Imaging. To make a representation or imitation of the original sonic event.

Impedance. The total opposition offered by an electric circuit to the flow of an alternating current of a single frequency. It is a combination of resistance and reactance and is measured in ohms. Remember that a speaker's impedance changes with frequency, it is not a constant value.

Inductance. The property of an electrical circuit by which a varying current in it produces a varying magnetic field that introduces voltages in the same circuit or in a nearby circuit. It is measured in henrys.

Inductor. A device designed primarily to introduce inductance into an electrical circuit. Sometimes called a choke or coil.

Linearity. The extent to which any signal handling process is accomplished without amplitude distortion.

Midrange. The middle frequencies where the ear is the most sensitive.

NAC. The abbreviation for natural ambience compensation.

Passive crossover. Uses no active components (transistors, ICs, tubes) and needs no power supply (AC, DC, battery) to operate. The crossover in a typical loudspeaker is of the passive variety. Passive crossovers consist of capacitors, inductors and resistors.

Phase. The amount by which one sine wave leads or lags a second wave of the same frequency. The difference is described by the term phase angle. Sine waves in phase reinforce each other; those out of phase cancel.

Pink noise. A random noise used in measurements, as it has the same amount of energy in each octave.

Polarity. The condition of being positive or negative with respect to some reference point or object.

RMS. Abbreviation for root mean square. The effective value of a given waveform is its RMS value. Acoustic power is proportional to the square of the RMS sound pressure.

Resistance. That property of a conductor by which it opposes the flow of electric current, resulting in the generation of heat in the conducting material, usually expressed in ohms.

Resistor. A device used in a circuit to provide resistance.

Resonance. The effect produced when the natural vibration frequency of a body is greatly amplified by reinforcing vibrations at the same or nearly the same frequency from another body.

Sensitivity. The volume of sound delivered for a given electrical input.

Stator. The fixed part forming the reference for the moving diaphragm in a planar speaker.

THD. The abbreviation for total harmonic distortion. (See Distortion)

TIM. The abbreviation for transient intermodulation distortion.

Transducer. Any of various devices that transmit energy from one system to another, sometimes one that converts the energy in form. Loudspeaker transducers convert electrical energy into mechanical motion.

Transient. Applies to that which lasts or stays but a short time. A change from one steady-state condition to another.

Tweeter. A small drive unit designed to reproduce only high frequencies.

Wavelength. The distance measured in the direction of progression of a wave, from any given point characterized by the same phase.

White noise. A random noise used in measurements, as it has the same amount of energy at each frequency.

Woofers. A drive unit operating in the bass frequencies only. Drive units in two-way systems are not true woofers but are more accurately described as being mid/bass drivers.



WARNING! Do not use your Dynamo 1000 loudspeakers outside of the country of original sale—voltage requirements vary by country. Improper voltage can cause damage that will be potentially expensive to repair. The Dynamo 1000 is shipped to authorized MartinLogan distributors with the correct power supply for use in the country of intended sale. A list of authorized distributors can be accessed at www.martinlogan.com or by emailing info@martinlogan.com.



Lawrence, Kansas, USA tel 785.749.0133 fax 785.749.5320 www.martinlogan.com