

User's Manual

The Monolith III Speaker System



Important

Your Martin-Logan speakers are provided with automatic Limited 90 Day Warranty coverage.

You have the option, at no additional charge, to receive Limited 3 Year Warranty coverage. To obtain Limited 3 Year Warranty coverage you need only complete and return the *Certificate of Registration* that was included with your speakers to Martin-Logan, within 30 days of purchase.

If you did not receive a Certificate of Registration with your speakers, you cannot be assured of having received new units. If this is the case, please contact Martin-Logan.

We know you are anxious to listen to your new speakers. So, to speed you along, we have provided an *Installation in Brief* section ahead of the detailed descriptive information contained in this manual.

Please read and follow these instructions for installation in brief as you initially connect your speakers into your system. These instructions are important and will prevent you from experiencing any delay, frustration, or system damage which might occur in a trial-and-error procedure.

The other sections of your User's Manual will explain in detail the operation of your speakers and the philosophy applied to their design. A clear understanding of your speakers will insure that you obtain maximum performance and pleasure from this most exacting transducer.

Contents

Introduction	3
Installation in Brief	4
Monolith III Specifications	5
History	6
Connection	8
IIIp Connection	9
IIIx Connection	12
IIIx Operation	14
IIIx Technical Description	16
Room Acoustics	18
Placement	21
General Information	23
The Electrostatic Concept	24
Martin-Logan Exclusives	26
Questions	28
Troubleshooting	29
Glossary	30

Introduction

Congratulations, you have invested in one of the world's premier loudspeaker systems!

The Martin-Logan MONOLITH III represents the culmination of an intensive, dedicated group research program directed toward establishing a world class reference monitor utilizing leading-edge technology, without compromising durability, reliability, craftsmanship, or aesthetic design.

The original Monolith made its official debut in June of 1982 at the International Consumer Electronics Show where it was selected for the prestigious *Design and Engineering Exhibition* as one of the most innovative consumer electronics products of that year. Since then, the Monolith has become the speaker of choice by the most demanding musicians, electronics manufacturers, and recording studios, as well as the most discerning critical listeners.

As a result of our continuous research and development program here at Martin-Logan, we decided that it was time to incorporate some of our latest technologies into the already outstanding Monolith. So, in January of 1990 we introduced the MONOLITH III to the marketplace.

With the MONOLITH III, we have advanced the current state of the art in

many areas of loudspeaker design. Bass response has better extension, superior impact and improved definition, high frequency response also has better extension and is much more natural in character. Much effort was spent on minimizing all diffractive or reflective surfaces. This has improved overall transparency and image quality.

In addition, a great amount of energy was spent on the interface between the electrostatic element and the woofer, with astonishing results. The fruit of this labor has brought us the passive IIIp INTERFACE and the superior electronic IIIx CROSSOVER. With either of these two devices, the transition from the electrostatic element to the woofer becomes invisible and an unbelievable continuity of sound prevails. With the IIIx CROSSOVER another veil is lifted and you are brought even closer to the musical truth. Dynamic information suddenly becomes frightening. Power handling and system efficiency are enhanced as well.

Like the original Monoliths, all materials in your new MONOLITH III speakers are of the highest quality to provide years of enduring enjoyment and deepening respect. All trim pieces are constructed from selected hardwoods. They are then grain and color matched and finally hand finished. The cabinetry is constructed from a special high-density

hardwood powderboard for structural integrity and is finished with a durable and attractive leatherette.

Through rigorous testing, the curvilinear electrostatic panel manufactured and used by Martin-Logan has proven itself to be one of the most durable and reliable transducers available today. Fabricated from a specially tooled, high-grade steel, the panel is then coated with a special high dielectric nylon/Delrin based polymer that is applied via a proprietary electrostatic deposition process. This panel assembly houses a membrane 0.0005 of an inch thick! Ruggedly constructed and insulated, as much as 200 watts of continuous power has driven the MONOLITH III's energized diaphragm into massive excursions with no deleterious effects.

We again thank you for purchasing the MONOLITH III. By following the *Installation in Brief* instructions you may connect them to your system, sit back, relax, and enjoy this most exacting transducer. It has been designed and constructed to give you years of trouble-free listening enjoyment.

Happy Listening!

Installation in Brief

We know you are eager to hear your new MONOLITH III loudspeakers, so this section is provided to allow fast and easy set up. Once you have them operational, please take the time to read, in depth, the rest of the information in this manual. It will give you perspective on how to obtain the best possible performance from this most exacting transducer.

If you should experience any difficulties in the set-up or operation of your MONOLITH III speakers please refer to the *Room Acoustics*, *Placement* or *Connection* section of this manual.

Should you encounter a persistent problem that cannot be resolved, please contact your Authorized Martin-Logan dealer. He will provide you with the appropriate technical analysis to alleviate the situation.

Step 1: Placement

Place each Monolith at least two feet from any wall and slightly angle them toward your listening area. This is a good place to start. Please refer to the *Room Acoustics* and *Placement* sections of this manual for more details.

Step 2: Power Connection (AC)

Martin-Logan Monoliths require AC power to energize their electrostatic cells. Using the AC power cords provided, plug them in, making sure that you have made a firm connection, first to the AC power receptacle on the rear panel of the speaker and then to the wall outlet. Extension cords may be used, if necessary, since the AC power requirement of the Monolith is extremely small.

Step 3: Signal Connection

WARNING !

*Turn your amplifier off before making or breaking any signal connections!
The chassis is earth grounded and can present a short circuit to your amplifier if contact is made!*

Use the best speaker cables you can! 16 gauge zip-cord is the minimum you should use, and higher quality cables, available from your specialty dealer, are recommended and will give you superior performance! Spade or banana connectors are suggested for optimum contact and ease of installation.

Be consistent when connecting speaker leads to the terminals on the back of the MONOLITH III: take great care to assign the same color to the (+) terminal on both the left and right channels. If bass is nonexistent and you cannot discern a tight, coherent image, reverse the (+) and (-) leads on one side to bring the system into proper polarity. Attach your speaker cables to the Amplifier Signal input section of the IIIp INTERFACE if you have the MONOLITH IIIp or directly to the appropriate Signal Input section on the back of the MONOLITH III if you are using the MONOLITH IIIx CROSSOVER. Please refer to the appropriate *Connection* section of this manual for further details and instructions.

Step 4: Listen and Enjoy

Now, you may turn on your system and enjoy!

Monolith III Specifications

The MONOLITH III hybrid speaker system consists of a broad-range single element electrostatic transducer integrated with a quick-response woofer. This approach takes maximum

advantage of the positive aspects that both technologies have to offer.

Dispersion is a controlled 30 degrees. This was achieved by curving the

electrostatic transducer element itself, an elegantly simple solution.

MONOLITH III SPEAKER

System Frequency Response

28-24,000 Hz +/-2dB

Electrostatic Frequency Response

95-24,000 Hz +/- 2dB

Woofer Frequency Response

28-2,000 Hz +/- 2dB

Dispersion

Horizontal: 30 Degrees
Vertical: 4' Line Source

Sensitivity

89dB/2.83 Volts/meter

Impedance

High-pass:

Nominal: 4 ohms, below 10kHz

Minimum: 1 ohm @ 20kHz

Low-pass:

Nominal: 4 ohms

Minimum: 4 ohms

Power Handling

250 watts per channel

Recommended Amplifier Power

80 - 250 watts per channel

Weight

120 lbs/speaker; 54.4 kg/speaker

Size (HWD)

73.75" x 26.75" x 11.75"

187.3cm x 67.9cm x 29.8cm

Components

Glass-epoxy boards, custom-wound audio transformers, 30-amp gold plated binding posts, regulated HV power supply

IIIp INTERFACE

Crossover Frequency

125 Hz @ 12dB/octave

Impedance

Nominal: 4 ohms, below 10kHz

Minimum: 1 ohms @ 20kHz

Components

Glass-epoxy boards, polypropylene capacitors, 100% OFC coils, wirewound resistors, 30-amp gold plated binding posts, non-ferrous enclosure

IIIx CROSSOVER

Crossover Frequency

125 Hz: @12dB/octave low-pass

@18dB/octave high-pass

Input Impedance

47,000 ohms

Output Impedance

100 ohms

Distortion

0.003% THD @ 1kHz @ 1Vrms

Signal to Noise

Greater than -95dB

Circuit Topology

Audio circuits are fully complimentary, class-A current-biased J-FET buffers that isolate passive filter networks.

Power supply employs a toroidal transformer, discrete voltage and self-tracking current regulation. 40-volt peak to peak swing allows for 30dB of dynamic headroom.

Components

Glass-epoxy boards, metal film resistors, polypropylene capacitors, hand picked J-FETs, TIFFANY input/output connectors

History

In the late 1800's, any loudspeaker was considered exotic. Today, most of us take the wonders of sound reproduction for granted.

It was 1880 before Thomas Edison had invented the first phonograph. This was a horn-loaded diaphragm that was excited by a playback stylus. In 1898, Sir Oliver Lodge invented a cone loudspeaker, which he referred to as a "bellowing telephone", that was very similar to the conventional cone loudspeaker drivers that we know today. However, Lodge had no intention for his device to reproduce music, because in 1898 there was no way to amplify an electrical signal! As a result, his speaker had nothing to offer over the acoustical gramophones of the period. It was not until 1906 that Dr. Lee DeForrest invented the triode vacuum tube. Before this, an electrical signal could not be amplified. The loudspeaker, as we know it today, should have ensued then, but it did not. Amazingly, it was almost twenty years before this would occur.

In 1921, the electrically cut phonograph record became a reality. This method of recording was far superior to the mechanically cut record and possessed almost 30 dB of dynamic range. The acoustical gramophone couldn't begin to reproduce all of the information on this new disc. As a result, further developments in loudspeakers were needed to cope with this amazing new recording medium.

By 1923, Bell Telephone Laboratories made the decision to develop a complete musical playback system consisting of an electronic phonograph

and loudspeaker to take advantage of the new recording medium. Bell Labs assigned the project to two young engineers, C.W. Rice and E.W. Kellogg.

Rice and Kellogg had a well equipped laboratory at their disposal. This lab possessed a vacuum tube amplifier with an unheard of 200 watts, a large selection of the new electrically cut phonograph records and a variety of loudspeaker prototypes that Bell Labs had been collecting over the past decade. Among these were Lodge's cone, a speaker that used compressed air, a corona discharge (plasma) speaker, and an electrostatic speaker.

After a short time, Rice and Kellogg had narrowed the field of "contestants" down to the cone and the electrostat. The outcome would dictate the way that future generations would refer to loudspeakers as being either "conventional", or "exotic".

Bell Laboratory's electrostat was something to behold. This enormous bipolar speaker was as big as a door. The diaphragm, which was beginning to rot, was made of the membrane of a pig's intestine that was covered with fine gold leaf to conduct the audio signal.

When Rice and Kellogg began playing the new electrically cut records through the electrostat, they were shocked and impressed. The electrostat performed splendidly. They had never heard instrumental timbres reproduced with such realism. This system sounded like real music rather than the honking, squawking rendition of the acoustic gramophone. Immediately, they knew they were on to something big. The

acoustic gramophone was destined to become obsolete.

Due to Rice and Kelloggs enthusiasm, they devoted a considerable amount of time researching the electrostatic design. However, they soon encountered the same difficulties that even present designers face; planar speakers require a very large surface area to reproduce the lower frequencies of the audio spectrum. Because the management at Bell Labs considered large speakers unacceptable, Rice and Kelloggs work on electrostatics would never be put to use for a commercial product. Reluctantly, they advised the Bell management to go with the cone. For the next thirty years the electrostatic design lay dormant.

During the Great Depression of the 1930's, consumer audio almost died. The new electrically amplified loudspeaker never gained acceptance, as most people continued to use their old Victrola-style acoustic gramophones. Prior to the end of World War II, consumer audio saw little, if any, progress. However, during the late 1940's, audio experienced a great rebirth. Suddenly there was tremendous interest in audio products and with that, a great demand for improved audio components. No sooner had the cone become established than it was challenged by products developed during this new rebirth.

In 1947, Arthur Janszen, a young Naval engineer, took part in a research project for the Navy. The Navy was interested in developing a better instrument for testing microphone arrays. The test instrument needed an

extremely accurate speaker, but Janszen found that the cone speakers of the period were too nonlinear in phase and amplitude response to meet his criteria. Janszen believed that electrostats were inherently more linear than cones, so he built a model using a thin plastic diaphragm treated with a conductive coating. This model confirmed Janszen's beliefs, for it exhibited remarkable phase and amplitude linearity.

Janszen was so excited with the results that he continued research on the electrostatic speaker on his own time. He soon thought of insulating the stators to prevent the destructive effects of arcing. By 1952 he had an electrostatic tweeter element ready for commercial production. This new tweeter soon created a sensation among American audio hobbyists. Since Janszen's tweeter element was limited to high frequency reproduction, it often found itself used in conjunction with woofers, most notably, woofers from Acoustic Research. These systems were highly regarded by all audio enthusiasts.

As good as these systems were, they would soon be surpassed by another electrostatic speaker.

In 1955, Peter Walker published three articles on electrostatic loudspeaker design in *Wireless World*, a British electronics magazine. In these articles Walker demonstrated the benefits of the electrostatic loudspeaker. He explained that electrostatics permit the use of diaphragms that are low in mass, large in area, and uniformly driven over their

surfaces by electrostatic forces. Due to these characteristics, electrostats have the inherent ability to produce a wide bandwidth, flat frequency response with distortion products being no greater than the electronics driving them.

By 1956 Walker backed up his articles by introducing a consumer product, the now famous Quad ESL. This speaker immediately set a standard of performance for the audio industry due to its incredible accuracy. However, in actual use the Quad had a few problems. It could not play very loud, it had poor bass performance, it presented a difficult load that some amplifiers did not like, its dispersion was very directional, and its power handling was limited to around 70 watts. As a result, many people continued to use box speakers with cones.

In the early 1960's Arthur Janszen joined forces with the KLH loudspeaker company and together they introduced the KLH 9. Due to the large size of the KLH 9, it did not have as many limitations as the Quad. The KLH 9 could play markedly louder and lower in frequency than the Quad ESL. Thus a rivalry was born.

Janszen continued to develop electrostatic designs. He was instrumental in the design of the Koss Model One, the Acoustech, and the Dennesen speakers. Roger West, the chief designer of the JansZen Corporation became the president of Sound Lab. When JansZen Corporation was sold, the RTR loudspeaker company bought half of the production tooling. This tooling was used to make the electrostatic panels

for the Servostatic, a hybrid electrostatic system that was Infinity's first speaker product. Other companies soon followed; each with their own unique applications of the technology. These include Acoustat, Audiostatic, Beverage, Dayton Wright, Sound Lab, and Stax to name a few.

Electrostatic speakers have progressed and prospered because they actually do what Peter Walker claimed they would. The limitations and problems experienced in the past were not inherent to the electrostatic concept. They were related to the applications of these concepts.

Today, these limitations have been addressed. Advancements in materials due to the U.S. space program give designers the ability to harness the superiority of the electrostatic principle. Today's electrostats use advanced insulation techniques or provide protection circuitry. The poor dispersion properties of early models have been addressed by using delay lines, acoustical lenses, multiple panel arrays or, as in our own products, by curving the diaphragm. Power handling and sensitivity have been increased.

These developments allow the consumer the opportunity to own the highest performance loudspeaker products ever built. It's too bad Rice and Kellogg were never able to see just how far the technology would be taken.

Connection

AC Power Connection

Electrostatic speakers use an internal power supply to energize their electrostatic elements with high-voltage DC (low current). As such, they must be connected to an AC wall outlet. For this reason we have provided your speakers with the proper IEC standard power cords. These cords should be firmly inserted into the AC power receptacles on the rear connection panel of the speakers, then to any convenient AC wall outlet. Extension cords may be used, if necessary, since the AC power requirement of the speaker is extremely small (less than 2.5 watts).

We do not recommend the use of "super cords", as many of these designs eliminate the ground prong of the male plug and therefore do not follow IEC convention standards. If proper plugs are fitted, then the choice is up to you.

Your Martin-Logan speakers have been designed to remain on continuously and should remain connected to a continuous AC power source. As mentioned earlier, power consumption of the MONOLITH III is very small and the life expectancy of its components will not be reduced by continuous operation.

The power cord should not be installed, removed, or left detached from the speaker while the other end is connected to an AC wall outlet.

Your Martin-Logan speakers are wired for the power service supplied in the country of original consumer sale unless manufactured on special order. The AC power rating applicable to a particular unit is specified both on the packing carton and on the serial number plate attached to the speaker.

If you remove your Martin-Logan speakers from the country of original sale, be certain that AC power supplied in any subsequent location is suitable before connecting and operating the speakers. Substantially impaired performance or severe damage may occur to a Martin-Logan speaker if operation is attempted from an incorrect AC power source.

If your home is not equipped with three-prong wall outlets, you may use "cheater" plugs to connect the speakers to AC power. However, please make certain that you connect the grounding wire or tab of the plug to a ground. These may be obtained at your dealer or any hardware department.

Signal Connection

Use the best speaker cables you can! The length and type of speaker cable used in your system will have an audible effect. Under no circumstance should a wire of gauge higher (thinner) than #16 be used. In general, the longer the length used, the greater the necessity of a lower gauge, and the lower the gauge, the better the sound, with diminishing returns setting in around #8 to #12.

A variety of speaker cables are now available whose manufacturers claim better performance than with standard heavy gauge wire. We have verified this in some cases, and the improvements available are often more noticeable than the differences between wires of different gauge.

We would also recommend, if possible, that short runs of speaker cable connect the power amplifier(s) and speakers and that high quality long interconnect cables be used to connect the preamplifier and power amplifier. This results in the power amplifiers being close to the speakers, which may be practically or cosmetically difficult, but if the length of the speaker cables can be reduced to a few meters, sonic advantages may be obtained. The effects of cables may be masked if the equipment is not of the highest quality.

Connections are done at the SIGNAL INPUT section on the rear electronics panel of the MONOLITH III. Use spade or banana connectors for optimum contact and ease of installation. Make certain that all your connections are clean, tight and positive.

Be consistent when connecting the speaker cables to the SIGNAL INPUT terminals. Take care to assign the same color cable lead to the (+) terminal on both the left and right channel speakers. If bass is nonexistent and you cannot discern a tight, coherent image, you probably need to reverse the (+) and (-) leads on one speaker to bring the system into proper polarity.

The MONOLITH IIIp INTERFACE provides you with three different methods for connecting the MONOLITH III to your audio system, while the superior MONOLITH IIIx CROSSOVER uses active bi-amplification.

IIIp Connection

ONE: Standard Connection for MONOLITH IIIp.

Please take note of the jumpers installed across the binding posts of the IIIp INTERFACE. These jumpers attach the high-pass and the low-pass sections of the interface together. Leaving these in place, connect the (+) wire from your amplifier to either of the red AMPLIFIER SIGNAL binding posts of the Interface and the (-) wire to either of the black posts. Next, connect the IIIp INTERFACE to the MONOLITH III with the provided cables. See *Figure 1*.

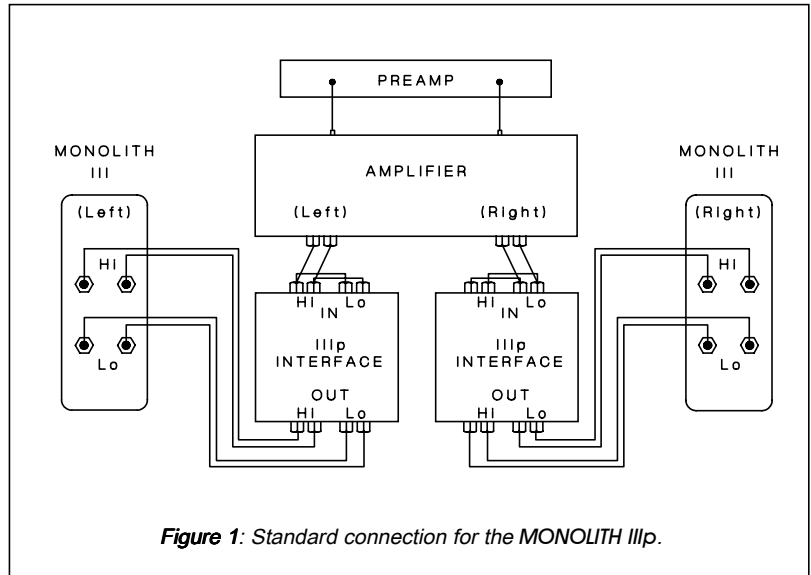

Figure 1: Standard connection for the MONOLITH IIIp.

TWO: Bi-wire Connection for the MONOLITH IIIp.

This method of connection replaces the jumpers installed across the binding posts of the IIIp INTERFACE with individual runs of speaker wire from your amplifier. This doubles the signal carrying conductors from the amplifier to the speaker thus, direct-coupling each portion of the crossover to the amplifier.

To bi-wire you must first remove the jumpers from the IIIp INTERFACE. Connect one set of wires to the HI+ and HI- binding posts of the IIIp INTERFACE. Then connect a second set of wires to the LO+ and LO- binding posts. Next, connect both sets of wires to the appropriate terminals on your amplifier. See *Figure 2*. Please take care to connect both (+) wires to the (+) amplifier terminals and both (-) wires to the (-) amplifier terminals. This is known as a parallel connection.

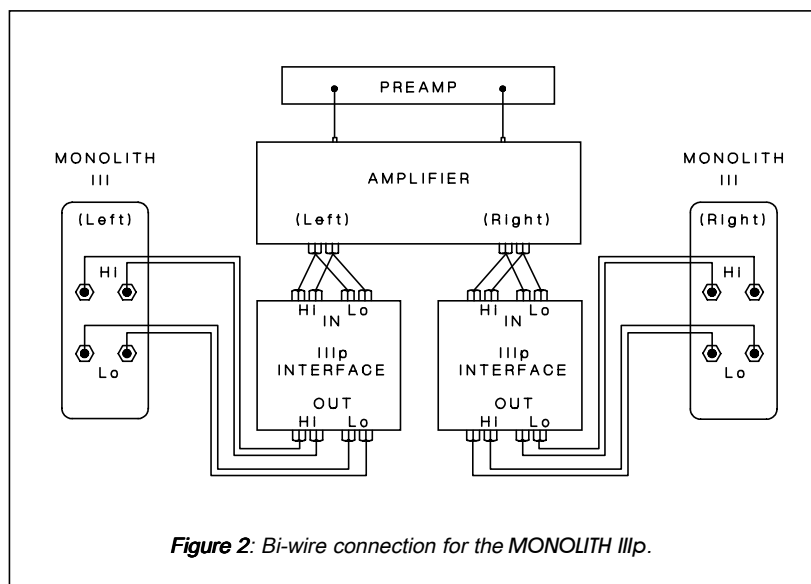

Figure 2: Bi-wire connection for the MONOLITH IIIp.

IIIp Connection

THREE: Passive Bi-amplification.

The MONOLITH III may be passively bi-amplified using the IIIp INTERFACE.

You cannot use an external electronic crossover with the MONOLITH III (other than the IIIx CROSSOVER which replaces the IIIp INTERFACE)!

Passive bi-amplification takes the bi-wiring concept one step further. Now you will have a dedicated channel of amplification directly connected to the high and low-pass sections of the crossover.

There are two different methods to passively bi-amplify. The first, and most common, is referred to as Horizontal Bi-amping. The second method that is gaining in popularity is referred to as Vertical Bi-amping. With either method you may use two stereo amplifiers, or four mono amplifiers, or two mono amplifiers and one stereo amplifier. Get the idea here? With either form of passive bi-amplification, your pre-amplifier must have dual

outputs. If your pre-amplifier is not so equipped then you must purchase or construct a "Y" adapter.

Horizontal bi-amping allows you to use two different types, models or brands of amplifiers (i.e. tubes on top, transistor on the bottom), assuming that they have identical gain or that one stereo pair has adjustable gain.

However, we recommend that you use two identical amplifiers (i.e. same brand and model). If the amplifiers of choice do not have the same gain characteristics, then a sonic imbalance will occur between the high-pass and low-pass sections of the speaker and integration between the two will suffer greatly. By using identical amplification on the high-pass and the low-pass you will

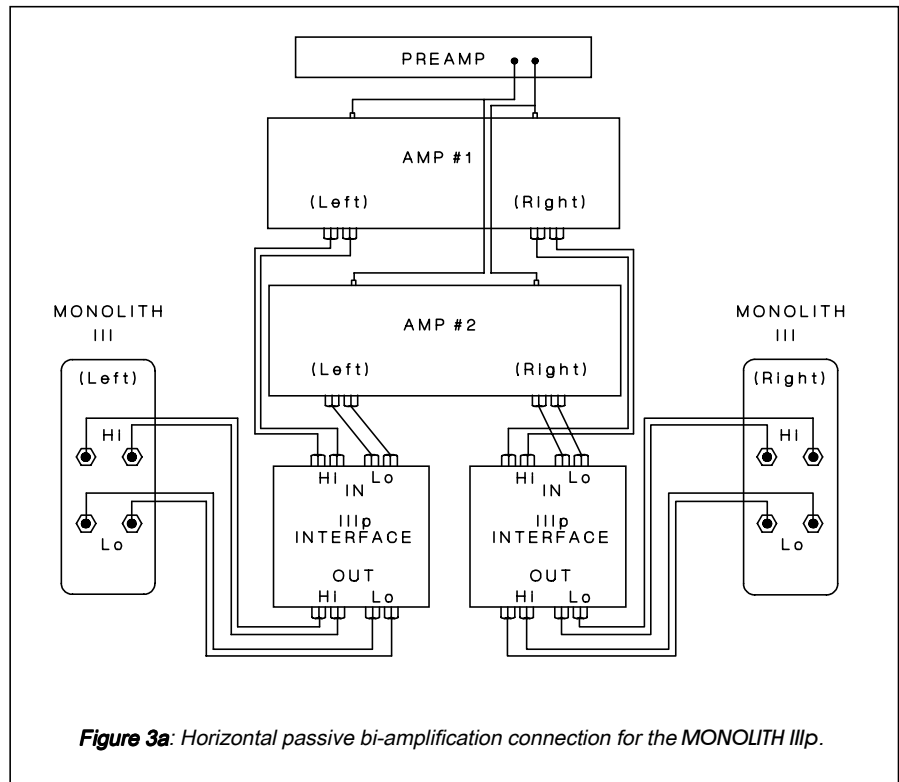

Figure 3a: Horizontal passive bi-amplification connection for the MONOLITH IIIp.

eliminate the negative effects of time delay (also referred to as group delay) that occurs when a signal passes through two dissimilar amplifiers. The very nature of vertical bi-amping dictates that both amplifiers be identical.

With **horizontal bi-amping**, one amplifier drives the high-pass section while the second amplifier drives the

low-pass section. To **horizontally bi-amp** your Monoliths you must remove the jumpers from the AMPLIFIER SIGNAL binding posts of the Illp INTERFACE. Connect the low frequency amplifier to the **LO+** and **LO-** AMPLIFIER SIGNAL binding posts of each Illp INTERFACE. Connect the high frequency amplifier to the **HI+** and **HI-** binding posts. Next connect the left and right preamplifier

outputs to the appropriate left and right inputs of both amplifiers. See *Figure 3a*.

With **vertical bi-amping**, each of the stereo amplifiers is dedicated to one speaker. For instance, the left channel of each amplifier drives the low-pass section while the right channel drives the high-pass section. To **vertically bi-amp** your Monoliths, you must remove the jumpers from the AMPLIFIER SIGNAL binding posts of each Illp INTERFACE. Start by connecting the left amplifier channel of amplifier #1 to the **LO+** and **LO-** binding posts and the right amplifier channel of amplifier #1 to the **HI+** and **HI-** binding posts of the Illp INTERFACE. Then repeat the same procedure for the other speaker with amplifier #2. Connect the left preamplifier outputs to both inputs of the left channel amplifier (#1) and the right preamplifier outputs to both inputs of the right channel amplifier (#2). See *Figure 3b*.

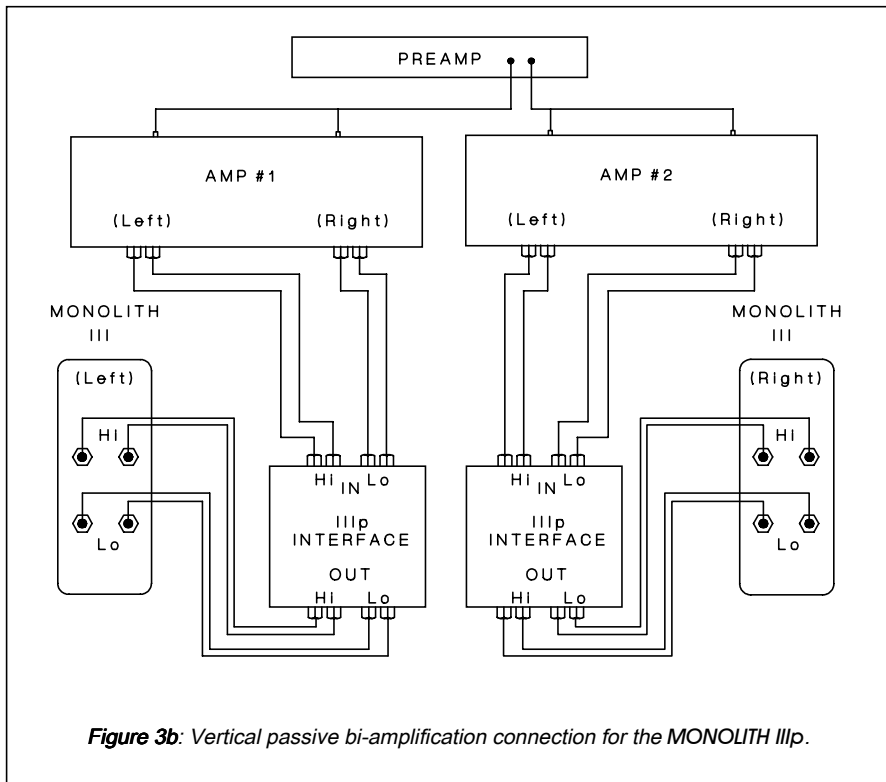

IIIx Connection

Introduction

The MONOLITH IIIx system utilizes the electronic IIIx CROSSOVER which incorporates technology developed for our STATEMENT SYSTEM CROSSOVER. Use of the MONOLITH IIIx CROSSOVER will result in substantial improvements in all aspects of your system's performance. Bass will be more extended with more impact and control. Special bass contour controls allow you to tailor the bass response to suit your particular room environment or listening tastes. The crossover region between the woofer and electrostatic panel is optimized, thus making the system blend much more homogeneous. Highs are much more extended, detailed and effortless. The system becomes much more dynamic with less strain. To understand why this occurs, we need to look at the differences between a single amplified system versus a properly interfaced bi-amplified system.

In a single amplified system, the left and right full-bandwidth signals pass from the preamplifier to a stereo power amplifier (or two mono amplifiers) and then to the loudspeaker's crossover, unchanged (we hope) except for amplitude. Once these signals reach

the crossover of the speaker they are divided into high and low frequency signals. The lower frequency signals are then directed to the woofers, while the high frequencies are routed to the electrostatic panels. This is known as a high-level passive crossover. This means that the frequency division of the signal is done after the power amplifier at high power (several volts) by means of passive components (capacitors, resistors, inductors and transformers).

When bi-amplifying with the MONOLITH IIIx CROSSOVER, the right and left full-bandwidth signals are divided into separate high and low frequency signals after the pre-amplifier by means of an active electronic crossover. These signals are then fed to dedicated high and low frequency amplifiers. This is referred to as a low-level active crossover, because all frequency division of the signal is done at line level at very low power (millivolts) with active components (transistors).

This configuration has several advantages. With the frequency division of the signal done prior to amplification, each amplifier has only to contend with

frequencies of a narrow bandwidth, thus it cannot combine high and low frequency signals and produce sum and difference by-products (intermodulation distortion or IM). For example, to reproduce deep bass such as an organ tone or kick drum, very high power (current) is needed. Since the low frequencies have their own dedicated amplifier, this demand for low frequency power will not affect the ability of the high frequency amplifier to perform its function normally, whereas if all frequencies were reproduced by the same amplifier, its power supply might temporarily be depleted by the deep bass passage, causing dynamic compression or clipping of the high frequency material.

Another added benefit of bandwidth limiting an amplifier, particularly the high frequency amplifier, is the slight increase in dynamic power output that occurs. The amplifier does not have to work as hard due to the reduction in the bandwidth amplification requirements. Therefore the amplifier can apply more power into the smaller frequency region.

Warnings

To prevent fire or shock hazard, do not expose the MONOLITH IIIx CROSSOVER to rain or moisture.

Hazardous voltage potentials exist in this crossover. Do not operate with the cover removed. There are no user serviceable components inside. Refer servicing to your authorized Martin-Logan dealer only.

Packaging

Please save all packaging and store in a dry place away from potential fire hazard. Your MONOLITH IIIx CROSSOVER is a precision electronic instrument and should be packaged properly in its original carton any time shipment is necessary. We hope that you will never

have occasion to return your unit to our factory for service, but in the event that servicing should prove necessary, or other occasion requiring shipment occurs, the original packaging will protect your unit from unnecessary damage or delay.

AC Power Connection

Plug in AC mains only after all signal connections have been made and you have verified that both amplifiers are switched off.

We have provided your MONOLITH IIIx CROSSOVER with the proper IEC standard 3-conductor power cords with 3-prong grounding plug. This cord should be firmly inserted into the AC power receptacle located on the rear panel of the crossover, then to any

convenient AC wall outlet. For absolute protection, *do not defeat the power plug ground.* This provides powerline grounding of the MONOLITH IIIx CROSSOVER chassis and will protect you from electrical shock.

We do not recommend the replacement or use of "deluxe" or "super" AC power cords. Many of these designs eliminate the ground prong of the male plug and therefore do not follow IEC convention standards. As such, they present the possibility of shock hazard.

Your MONOLITH IIIx CROSSOVER has no power switch as it has been designed to remain on continuously and should remain connected to a continuous AC power source.

Your crossover is wired for the power service supplied in the country of original consumer sale unless manufactured on special order. The AC power rating applicable to a particular unit is specified both on the packing carton and on the serial number plate attached to the crossover.

Signal Connection

Insert your pre-amps' output cables into the crossovers' INPUT jacks, then connect your low-pass amplifiers' input cables to the crossovers' LOW OUTPUT jacks, and your high-pass amplifiers' input cables to the HIGH OUTPUT jacks.

Plug in AC mains only after all signal connections have been made and you have verified that both amplifiers are switched off.

Next, connect the speaker leads from the high-pass amplifier to the HI SIGNAL INPUTS on the back of the MONOLITH III. Then connect the low-pass amplifier to the LO SIGNAL INPUTS. Please refer to the pictorial diagram, *Figure 4*, at right.

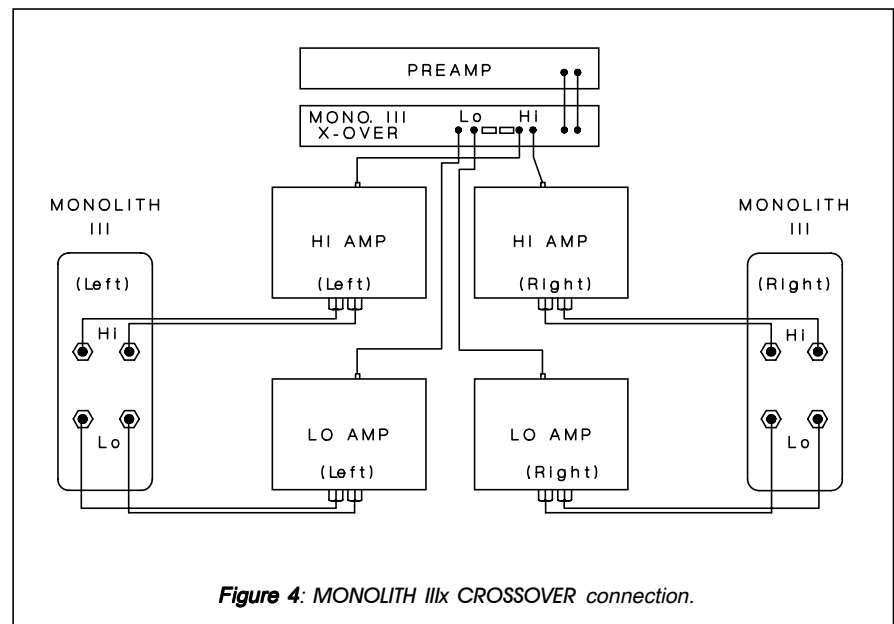

Figure 4: MONOLITH IIIx CROSSOVER connection.

IIIx Operation

Crossover Settings

Before you do any formal listening, you must set a pair of switches in the crossover. However, if you are using identical amplifiers (i.e. same make and model) for the high and low-pass sections of the Monolith, you may use the factory settings and skip this step.

On the back panel of the crossover there are two cut-outs that allow you to access two red dip switches. These switches adjust the low-pass gain so that you may balance the gain between the high-pass and low-pass amplifiers if they have different gain characteristics. We have even enclosed a red "dip stick" tool to assist you with this procedure.

The following formula will help you calculate the relative gain of your amplifiers:

Amplifier gain is defined as:

$$20 \log \left[\frac{\sqrt{(\text{Rated Output @ 8 ohms}) \times 8}}{\text{Input Sensitivity}} \right]$$

At right, in *Figure 5*, is a list of switch settings to help you select the proper gain switch settings.

As you detent the switch towards the **ON** position, you are engaging that switch. Each switch detent away from position **OFF** either increases or decreases the output of the low-pass amplifier. In order to properly engage a switch, you need to have all other switches in the **OFF** position. If the high-pass and low-pass amplifiers are identical or have the same gain, the system is designed to operate with both switches set to **OFF** (Position **OFF** represents 0dB of gain).

If equipped, the best way to obtain the

optimal setting is to locate the microphone of a spectrum analyzer in the room near your seating position, play pink noise through the system and begin to observe the relationship of the electrostatic transducer and the subwoofer at the crossover point which is 125 Hz. Your gain settings will be correct when the display is flat and consistent. You want the energy below 100 Hz to be roughly comparable to the energy above 100 Hz. If you now have reasonable tonal balance from 60 Hz onward to 200 Hz, then you have the optimal frequency balance at the crossover point.

Keep in mind that specifications and equipment can determine the best place to begin, but your ears are the most critical instruments available. Listen to music and adjust for your best personal balance.

Bass Contour Controls

You will notice that there are two controls on the front of the MONOLITH IIIx CROSSOVER. The left control is labeled *frequency* and the right control is labeled *boost/cut*. (See *Figure 6*.) These are a very accurate and precise pair of controls that allow you to adjust your speakers output in the most problematic area of music reproduction; the bass region.

Your Room and Bass

Today we are finding that all elements in the audio chain can and will affect your system's performance. Of these elements, your room is the worst offender. Once the precisely tailored musical signal is launched from your speaker system, your room then has

its way with that musical signal; particularly with the larger wavelengths of the bass region. Your room will enhance and cancel certain frequencies, making a perfect speaker look less than perfect in the best of instances and like a jumbled mess in the worst of instances. The front panel controls of the crossover can be used much like an accurate bass/

ON	GAIN	ON	GAIN
None	-6.0 dB	*5	+1.5 dB
*1	-4.5 dB	5&2	+2.0 dB
*2	-3.0 dB	5&3	+2.5 dB
2&1	-2.0 dB	*6	+3.0 dB
*3	-1.5 dB	6&3	+3.5 dB
3&1	-1.0 dB	6&5	+4.0 dB
*4	0 dB	*7	+4.5 dB
4&1	+0.5 dB	7&6	+5.0 dB
4&2	+1.0 dB	*8	+6.0 dB

Figure 5: Low-pass attenuation switch settings.
 NOTE: Start with "*" settings first, then fine tune using the intermediate settings.

room equalizer, designed to neutralize the specific problem areas of your room, thus helping you optimize the performance of the MONOLITH III.

Tuning Your Room

One of the best ways to assess how your room is affecting your system's performance is by doing a 1/3 octave analysis of your room. These devices, called 1/3 octave analyzers, may be obtained or rented from your dealer. Some dealers can even provide you with this analysis. The information gained by this analysis will help you establish the proper control settings for your MONOLITH IIIx CROSSOVER, thus allowing you to bring your system back to flat for optimal system performance.

If a real-time analyzer is not available, a simple sine-wave generator and your ears may be used. By attaching the sine-wave generator to your system and slowly and consistently

sweeping from 100 Hz to 20 Hz and back again, and listening in different places in your room for what we call room nodes, or depressions, you can hear where the room either emphasizes certain bass frequencies or cancels them. If you set the *frequency* control of the crossover to the same frequency as that of the "worst offender", and adjust the *boost/cut* control to its appropriate position (either up to cancel a void or down to cancel a peak), you should begin to establish a smooth progression from lows to highs. Your goal here is to have no lumps or recessions throughout the low frequency sweep.

If neither a real-time analyzer nor a sine-wave generator are available, put on your favorite musical cut with moving bass (bass information that moves up and down the scale). Listen carefully to this cut once or twice and note whether the progression of bass is smooth throughout the musical spectrum. If it is smooth and extended without any noticeable absences or

increases of music at each note, then you have an optimal sound with no need to adjust the crossover controls. However, if you note an absence or increase of energy at a specific area, adjust your *frequency* control to that frequency and boost or cut progressively depending on whether you want more bass or less bass. Here, experimentation will be the factor. Inevitably, this is the final experiment. Even after using a sine-wave generator or real-time analyzer you will want to listen and fine-tune your system with real music using your ears.

Remember, what we often perceive as deep bass actually occurs at 40 to 50 Hz. Energy below 30 Hz is virtually inaudible. You may sense it and feel it as pressurization and movement in your body, but you don't really hear it. So, when you are experiencing bass energy, you will probably want to set your controls in the 30 to 50 Hz range and adjust them accordingly.

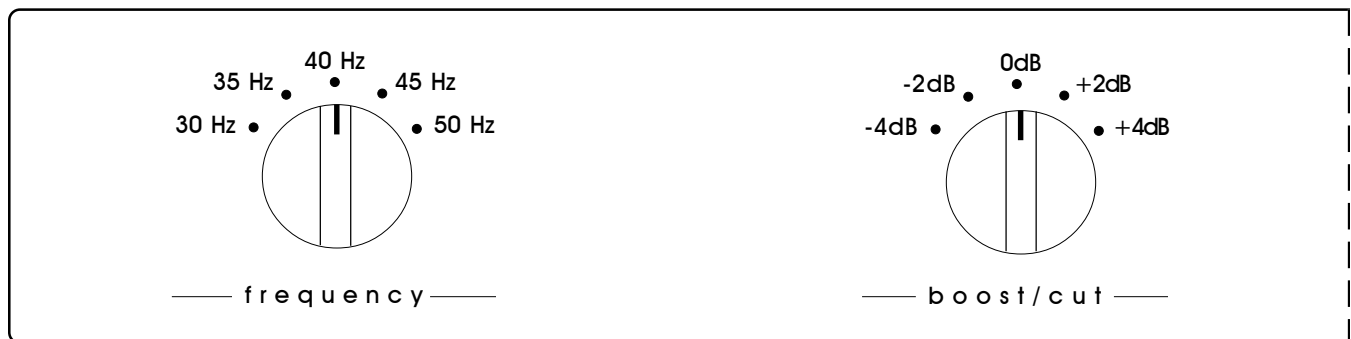

Figure 6: MONOLITH IIIx CROSSOVER Bass Contour controls.

Musical Tastes

An added benefit of the contour controls on the IIIx CROSSOVER, is the ability to adjust your speaker's personality to your style of listening.

It is well known that an "audiophile" listening priority is different from that of "rock" or "classic European" listening orientation. By setting your *frequency* control to 30 Hz and the *boost/cut* control to 0dB, you will have what is known as the "Audiophile setting". This setting allows the deepest bass extension and most linear theoretic performance. Experimenting slightly with the *boost/cut* control will give you either a drier or deeper and more extended performance. However, if a "rock" orientation is your preference, set the *frequency* control between 40 to 50 Hz with a slight boost, and you will get more of the emphasized percussive effect of rock music. The last priority, "classic European", consists of a dry, clean, very tight bass structure. It can be accomplished by resetting the *frequency* control to 30 Hz and turning down the *boost/cut* control. At this point, you will still have deep and extended bass, but it will be slightly rolled off to give you a very tight, defined performance level.

In the final evaluation, your ears will determine where these controls should be positioned. They have been established for your flexibility and use and can be used much like an accurate bass/room equalizer. So don't be afraid to experiment and have fun!

Theory of Operation

The audio signal coming from the pre-amplifier of your audio system is typically representative of a low impedance voltage source. There are a few preamplifiers, such as older tube designs, which may not conform to this, as they have a much higher output impedance. In addition many cables can change the preamplifiers output characteristics.

In order to assure a high level of performance with all types of preamps and cables, the MONOLITH IIIx CROSSOVER has a high input impedance, low output impedance buffer for its first stage. Furthermore, since there is no substitute for isolation to prevent various filter sections from interacting with each other (normally the high pass and low pass filters), the MONOLITH IIIx CROSSOVER has a separate buffer for the high-pass and the low-pass audio path.

These buffers are designed using two complimentary J-FET devices per buffer, strapped in unity gain, voltage follower topology. Two additional bipolar devices are used as current sources only, enabling the J-FETs to be completely current biased. This complimentary J-FET buffer is used repeatedly throughout the crossover, except for the output stage which requires gain.

In being a dedicated electronic crossover/equalizer, it is vital to tailor the system to the needs of the speaker. Planar speakers have two main areas of concern: 1) Rear wave cancellation, which causes a decrease in the speaker's output below 500 Hz, and 2) Primary resonance, which is the frequency the speaker is tuned to.

Rear wave cancellation requires corrective equalization beginning at 500 Hz and increasing to roughly 12dB at 100 Hz. Primary resonance affects this response as well, because the speaker is effectively out of control at primary resonance. A notch filter works well to negate the effects of this typically 12dB resonance. The decision of resonance tuning and rear wave cancellation compensation, combined in balance with the high frequency roll-off point, is a system decision based on the sonic properties of the speaker itself.

The MONOLITH IIIx CROSSOVER's high-pass pathway utilizes three separate filter sections; one for raising energy between 100 Hz and 500 Hz, emphasizing 100 Hz (referred to as a shelving filter), another for decreasing energy at the speaker resonance (notch filter) and a third high-pass filter.

The woofer has another set of requirements based upon its inherent displacement limitations. In order to recreate strong low frequency energy using a dynamic cone drive, a high QEQ driver in a large tuned (usually ported) box is required. The trade-off with this approach is poor speed, acceleration, and damping of the woofer driver. The superior performance of the electro-

static element demands that the woofer be a fast, quick-to-change, well damped driver so that it will blend with the electrostatic transducers characteristics properly. This is best obtained by using a low QEQ, low mass, small box design. However, to maintain good low frequency response with this approach, low frequency boost is required. Here, again, a shelving filter is used.

To prevent subsonic energy from taxing the listener, room, and driver, a subsonic high-pass filter is necessary. A third filter is reserved for low-pass filter operation. The characteristics of frequency and QEQ of each filter is affected by component value selection within each filter section.

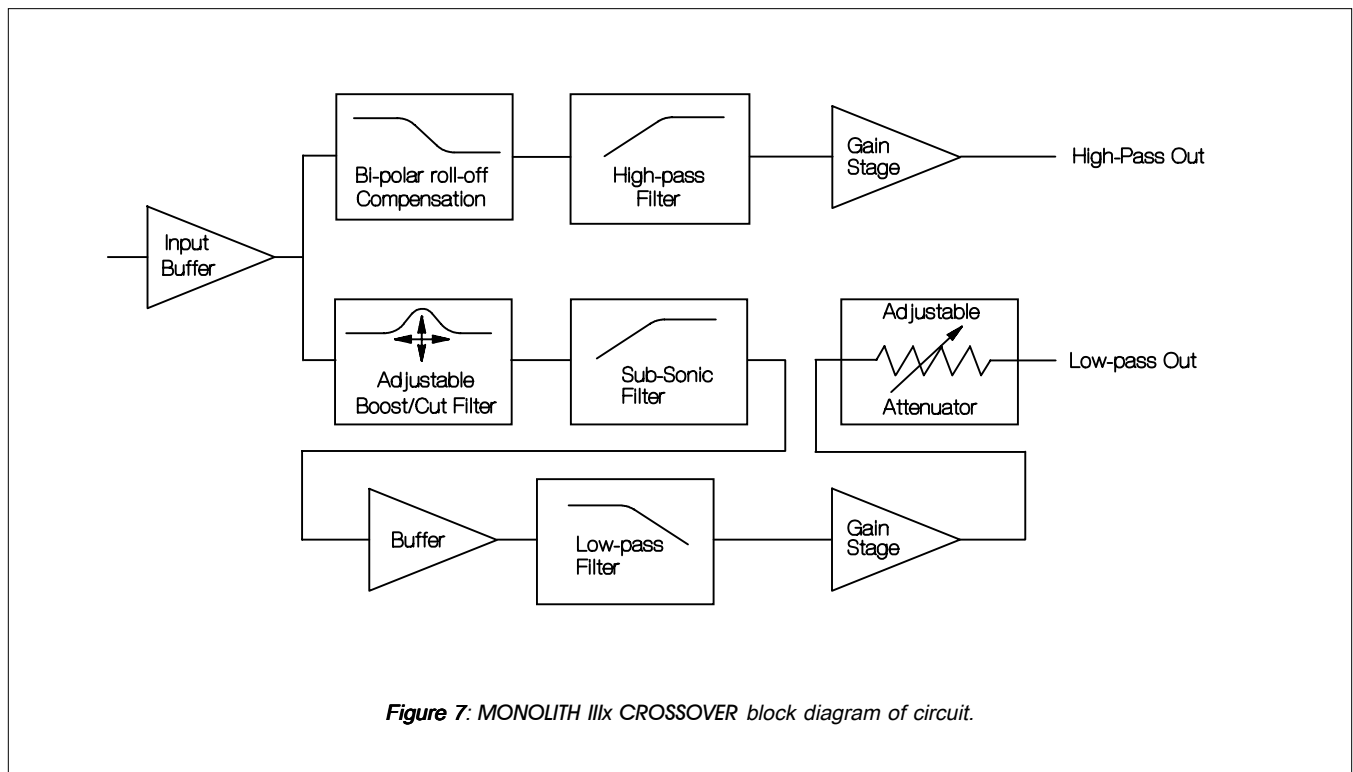

Room Acoustics

Your Room

This is one of those areas that requires a little background to understand and some time and experimentation to obtain the best performance from your system.

Your room is actually a component and an important part of your system. This component is a very large variable and can dramatically add to, or subtract from, a great musical experience, depending on how well you attend to it.

All sound is composed of waves. Each note has its own wave size, with the lower bass notes literally encompassing from 10' to as much as 40'! Your room participates in this wave experience like a 3 dimensional pool with waves reflecting and becoming enhanced depending on the size of the room and the types of surfaces in the room.

Remember, your audio system can literally generate all of the information required to recreate a musical event in time, space, and tonal balance. The purpose of your room, ideally, is to not contribute to that information. However, every room does contribute to the sound and the better speaker manufacturers have designed their systems to accommodate this phenomenon.

Let's talk about a few important terms before we begin.

Terminology

Standing Waves. The parallel walls in your room will reinforce certain notes to the point that they will sound louder than the rest of the audio spectrum and cause "one note bass", "boomy bass", or "tubby bass". For instance, 100Hz represents a 10' wavelength. Your room will reinforce that specific frequency if one of the dominant dimensions is 10'. Large objects in the room such as cabinetry or furniture can help to minimize this potential problem. Some serious "audiophiles" will literally build a special room with no parallel walls just to get away from this phenomenon.

Reflective Surfaces. The hard surfaces of your room, particularly if close to your speaker system, will reflect those waves back into the room over and over again, confusing the clarity and imaging of your system. The smaller sound waves are mostly affected here and occur in the mid and high frequencies. This is where voice and frequencies as high as the cymbals can occur.

Near Field Reflections. Those reflective surfaces of the room that are the closest to your speaker system, particularly if they are hard surfaces, can reflect the musical energy back into the room, confusing the imaging and tonal balance of your system. Excessive brightness can result from this condition and diffuse, ill defined imaging can easily occur if too many surfaces near your speakers are hard and sharp in their relative angle to your system.

Resonant Surfaces and Objects. All of the surfaces and objects in your room are subject to the frequencies generated by your system. Much like an instrument, they will vibrate and "carry on" in syncopation with the music and contribute in a negative way to the music. Ringing, boominess, and even brightness can occur simply because they are "singing along" with your music.

Resonant Cavities. Small alcoves or closet type areas in your room can be chambers that create their own "standing waves" and can drum their own "one note" sounds.

Clap your hands. Can you hear an instant echo respond back? You've got near-field reflections. Stomp your foot on the floor. Can you hear a "boom"? You've got standing waves or large panel resonances such as a poorly supported wall. Put your head in a small cavity area and talk loudly. Can you hear a booming? You've just experienced a cavity resonance.

Rules of Thumb

Hard vs. Soft Surfaces. If one surface of your room (wall, floor, ceiling) is hard, a good rule of thumb suggests to try to have the opposing surface soft. So, if you have a hard wall of glass or paneling on one side of the room, it is best to have drapery or wall hangings on the opposing wall. If you have a hard ceiling, it generally is a good idea to have a soft floor of carpeting or area rugs. Large, soft furniture also counts to help damp a highly reflective room.

This rule suggests that a little reflection is good. As a matter of fact, some rooms can be so "over damped" with carpeting, drapes and sound absorbers that the music system can sound dull and lifeless. On the other hand, rooms can be so hard that the system can sound like a gymnasium with too much reflection and brightness. The point is that balance is the optimum environment.

Break-up Objects. Objects with complex shapes, such as bookshelves, cabinetry, and multiple shaped walls can help to break up those sonic gremlins and diffuse any dominant frequencies.

Solid Coupling. Your loudspeaker system generates frequency vibrations or waves into the room. This is how it creates sound. Those vibrations will vary from 20 per second to 20,000 per second. If your speaker system is not securely planted on the floor or solid surface, it can shake as it produces sound, and consequently the sound can be compromised. If your speaker is setting on the carpet and only foot gliders are used, the bass can be ill defined and even boomy. Additionally, the imaging can be poorly located and diffuse if the system is not on solid footing.

Bipolar Speakers and Your Room

Martin-Logan electrostatic loudspeakers are known as bipolar radiators. This means that they produce sound from both their fronts and their backs. Consequently, musical information is reflected by the wall behind them and may arrive either in or out of step with the information produced by the front of the speaker.

The low frequencies can either be enhanced or nulled by the position from the back wall. Your Monoliths have been designed to be placed 2 to 3 feet from the back wall to obtain the best results, however your room may see things differently. So, listening to the difference of the bass response as a result of the changes in distance from the back wall can allow you to get the best combination of depth of bass and tonal balance.

The mid-range and high frequencies can also be affected, but in a different way. The timing of the first wave as it is first radiated to your ears and then the reflected information as it arrives at your ears later in time, can result in confusion of the precious timing information that carries the clues to imaging and, consequently result in blurred imaging and excessive brightness. Soft walls, curtains, wall hangings, or sound dampeners (your dealer can give you good information here) can be effective if these negative conditions occur.

Vertical Dispersion

As you can see from the illustrations, your Monolith III speakers project a controlled dispersion pattern. Each Monolith is a four foot line source beginning two feet above floor level. This vertical dispersion profile minimizes interactions with the floor and the ceiling.

Horizontal Dispersion

Your Monoliths launch a 30 degree dispersion pattern when viewed from above. This horizontal dispersion field gives you a choice of good seats for the performance while minimizing interactions with side walls.

Make sure both speakers stand exactly at the same vertical angle, otherwise the image can be skewed or poorly defined. The wave launch of both speakers is extremely accurate in both the time and spectral domain and, consequently small refined adjustments can result in noticeable sonic improvements.

Room Acoustics

Dispersion Concepts

In the field of loudspeaker design, it is common knowledge that as the wave becomes progressively smaller than the transducer producing it, the dispersion of that wave becomes more and more narrow, or directional. This occurs as long as the transducer is a flat surface.

Historically, most attempts to achieve smooth dispersion from large flat panel transducers resulted in trade-offs. After exhaustive testing of these different solution attempts, we found an elegantly simple, yet very difficult to execute solution. By curving the radiating

surface, we create the effect of a horizontal arc. This allows the engineers at Martin-Logan to control the high frequency dispersion pattern of our transducers. That is why you see the gentle curve on our products.

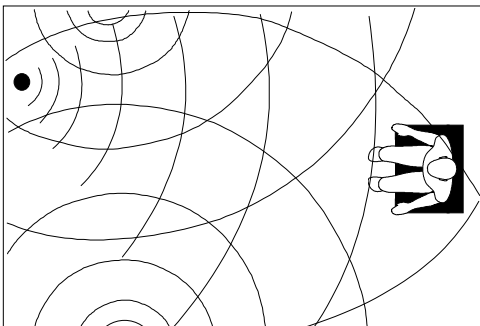

As can be seen, point source concepts invite a great deal of room interaction. While delivering good frequency response to a large listening audience, imaging is consequently confused and blurred.

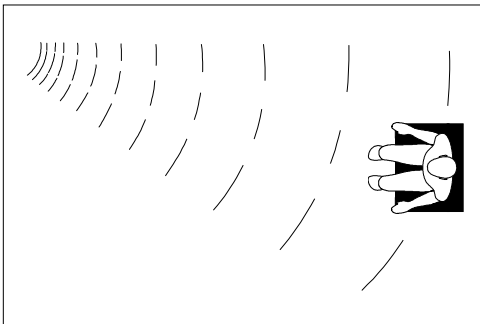
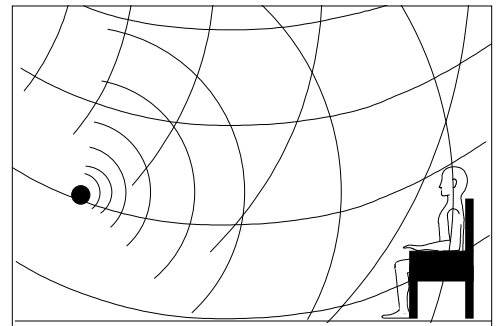

Even though they suffer from "venetian blind" effect, angled multiple panel speakers can deliver good imaging, but only to specific spots in the listening area.

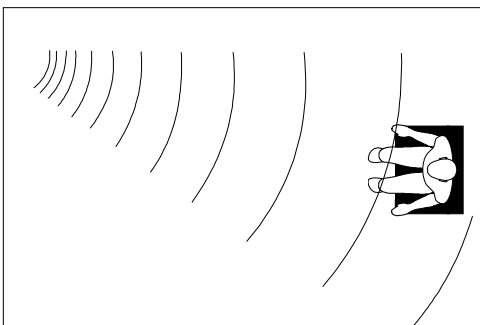
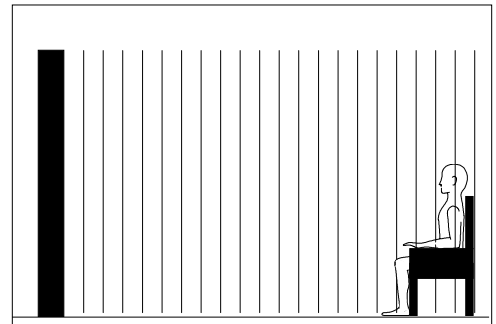

*A controlled 30-degree cylindrical wave-front, which is a **Martin-Logan exclusive**, offers optimal sound distribution with minimal room interaction. The result is solid imaging with a wide listening area.*

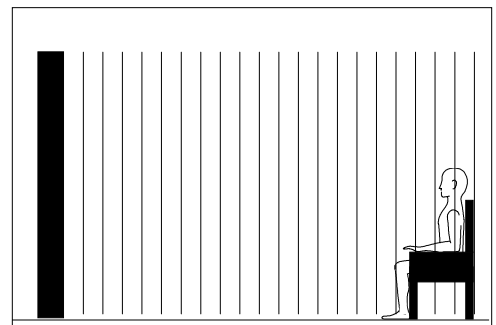

Placement

General Placement

Start by making certain that both speakers are the same distance from the walls behind or beside them and that their toe-in angle is the same. At this time you may want to enlist the help of a friend or family member to assist you.

It is generally true that, as you move your speakers farther forward into the listening environment, you will derive more spaciousness from them. Toeing them toward the middle of the listening area will enhance brightness.

As you place and listen, keep in mind that tight bass and clear resolution indicate proper placement and that the acoustical image is in focus. Don't hesitate to experiment, but give each new combination of positions a thorough test. The time and effort you invest here will be well spent.

By now your speakers should be placed approximately 2 to 3 feet from the back wall and at least 1 to 2 feet from the side walls. Your sitting distance should be further than the distance between the speakers themselves. What you are trying to attain is the impression of good center imaging and stage width.

There is no exact distance between speakers and listener, but there is a relationship. In long rooms, naturally, that relationship changes. The distance between the speakers will be far less than the distance from you to the speaker system. However, in a wide room you will still find that if the distance from the listener to the speakers becomes smaller than the distance between the speakers themselves, the image will no longer focus in the center.

Now that you have positioned your speaker system, spend some time listening. Wait to make any major changes in your initial set-up for the next few days as the speaker system itself will change subtly in its sound. Over the first 20 hours of play the actual tonal quality will change slightly with deeper bass and more spacious highs resulting.

After a few days of listening you can begin to make refinements and hear the differences of those refinements.

The Back Wall

Near-field reflections can also occur from your back wall. If your listening position is close to a back wall, these reflections can cause problems and confuse the quality of imaging. Actually it is better for the back wall to be soft than to be bright. If you have a hard back wall and your listening position is close to it, experiment with devices that will soften and absorb information, ie: wall hangings and possibly even sound absorbing panels.

The Front Wall

The wall behind your speakers should not be extremely hard or soft. For instance, a pane of glass will cause reflections, brightness, and confused imaging. Curtains, drapery, and objects such as bookshelving can be placed along the back wall to tame an extremely hard surface. A standard sheet rock or textured wall is generally an adequate back surface if the rest of the room is not too bright and hard.

Sometimes walls can be too soft. If the entire front wall consists of only heavy drapery, your system can literally sound too soft or dull. You will hear dull, muted music with little ambience. Harder room surfaces will actually help in this case.

The front surface should, optimally, be one long wall without any doors or openings. If you have openings, the reflection and bass characteristics from one channel to the other can be different.

The Side Walls

The same requirements exist for side walls. Additionally, a good rule of thumb is to have the side walls as far away from the speaker sides as possible, minimizing near field side wall reflections. Sometimes, if the system is bright or the imaging is not to your liking, and the sidewalls are very near, try putting curtains or softening material directly to the edge of each speaker. An ideal side wall, however, is no side wall at all.

Placement

Experimentation

Toe-in.

Now you can begin to experiment. First begin by toeing your speakers in towards the listening area and then toeing them out. You will notice that the tonal balance changes ever so slightly. You will also notice the imaging changing ever so slightly. Generally it is found that the ideal listening position is with the speakers slightly toed-in so that you are listening to the inner third of the curved transducer section.

Experimenting with the toe-in will help in terms of tonal balance. You will notice that as the speakers are toed-out, the system becomes slightly brighter than when toed-in. This design gives you the flexibility to modify a soft or bright room.

Tilting the Speakers.

(Backwards and Forwards)

As can be seen from the diagrams in the *Room Acoustics* section of this manual, the vertical dispersion is directional above and below the stat panel itself. If you sit in a tall chair, you may get better performance by tilting the speakers back so that the high frequencies are on axis with your ears. Otherwise, with a normal sofa and normal listening, tilt the speakers only slightly back if not straight up. Make sure, when listening, that the vertical alignment, distance from the back wall, and toe in is exactly the same from one speaker to the other. This will greatly enhance the quality of your imaging.

Imaging.

In their final location, your Monoliths should have a stage width somewhat wider than the speakers themselves. On well recorded music, the instruments should extend beyond the edges of each speaker to the left and to the right, yet a vocalist should appear directly in the middle. The size of the instruments should be neither too large nor too small. Additionally, you should find good clues as to stage depth.

Bass Response.

Your bass response should neither be one note nor should it be too heavy. It should extend fairly deep to all but the deepest organ passages yet it should be tight and well defined. Kick-drums should be tight and percussive, string bass notes should be uniform and consistent throughout the entirety of the run without any booming or thudding.

Tonal Balance.

Voices should be natural and full, cymbals should be detailed and articulate yet not bright and piercing, pianos should have a nice transient characteristic and deep tonal registers as well. If you cannot attain these virtues, re-read the section on *Room Acoustics*. This will give you clues on how to get closer to those ideal virtues.

A Final Word

Final Placement.

After obtaining good wall treatments and attaining proper angle, begin to experiment with the distance from the back wall. Move your speaker slightly forward into the room. What happened to the bass response? What happened to the imaging? If the imaging is more open and spacious and the bass response tightened, that is a superior position. Move the speakers back six inches from the initial set-up position. Again, listen to the imaging and bass response. There will be a position where you will have pin-point imaging and good bass response. That position becomes the point of the optimal placement from the back wall.

Now experiment with placing the speakers farther apart. As the speakers are positioned farther apart, listen again, not so much for bass response but for stage width and good pin-point focusing.

Your ideal listening position and speaker position will be determined by the following:

1. Tightness and extension of bass response.
2. The width of the stage.
3. The pin-point focusing of imaging.

Once you have found the best of all three of those considerations, you will have your best speaker location.

General Information

Associated Equipment

Your Martin-Logan Dealer was carefully selected by our company because they are knowledgeable, experienced and dedicated to musical excellence and customer satisfaction.

They have the ability to help you acquire the very best in audio equipment. They are likely to choose that equipment from among a small group of manufacturers that are committed to the faithful recreation of music.

Your new MONOLITH III speakers are quite honest in revealing the relative strengths and weaknesses of the equipment used with them. While the Monolith will bring to life the sonic delights of state-of-the-art components, it will with equal clarity bring out any system flaws. This does not mean that expensive equipment is a prerequisite to good sound from the Monolith, but rather that the equipment must be wisely selected and setup with care. The rewards will be well worth the effort.

As time goes by, you may find it instructive to discuss with your dealer the merits and advantages of carefully upgrading certain pieces of your associated equipment.

Care

The Martin-Logan Monolith has been carefully designed and precisely engineered. With a little care you can rest assured that they will continue to look as good as they sound for years to come.

Do not spray any cleaning solutions on the electrostatic element, as this could impair the speakers performance. Dust may be removed with a brush attachment on a vacuum cleaner or you may blow it off with compressed air. Silicone dusting sprays, abrasive or solvent-based cleaners should **not** be used on any portions of the speaker.

Solid Footing

It is best to have a the Monoliths coupled firmly with the floor. After living and experimenting with the placement of your Monoliths, you should use the spikes included in your owners kit. Bass response will tighten and imaging will become more coherent, fixed and detailed. It is best not to implement the spikes however, until you have decided upon the final placement of the speaker, as they can damage the floor if the speaker is moved.

Enjoy Yourself

The MONOLITH III is a very refined speaker and, as such, benefits from careful set-up. With the information in this manual in mind, you will find, over your months of listening, that small changes can result in demonstrable differences. As you live with your speakers, do not be afraid to experiment with their positioning until you find the optimal relationship between your room and your speaker system. Your efforts will be rewarded.

You are now armed with the basics of room acoustics and the specific fundamentals of the MONOLITH III loudspeaker system. Enjoy yourself and happy listening.

The Electrostatic Concept

How is it that music can be recreated by something that you are able to see through? Electrostatic energy makes this possible.

Where the world of traditional loud-speaker technology deals with cones, domes, diaphragms, and ribbons that are moved with magnetism, the world of electrostatic loudspeakers deals with charged electrons attracting and repelling each other.

To fully understand the electrostatic concept, some background information will be helpful. Remember when you learned, in a science or physics class back in high school, that like charges repel each other and that opposite charges attract each other? Well, this principle is the foundation of the electrostatic concept.

An electrostatic transducer consists of three pieces: the stators, the diaphragm and the spacers. (See *Figure 8.*) The

diaphragm is what actually moves to excite the air and create music. The stator's job is to remain stationary, hence the word stator, to provide a reference point for the moving diaphragm. The spacers provide the diaphragm with a fixed distance in which to move between the stators.

As your amplifier sends music signals to an electrostatic speaker, these

signals are changed into two high-voltage signals that are equal in strength but opposite in polarity. These high-voltage signals are then applied to the stators. The resulting electrostatic field, created by the opposing high voltage on the stators, works simultaneously with and against the diaphragm, consequently moving it back and forth, producing music. This technique is known as push-pull operation and is a

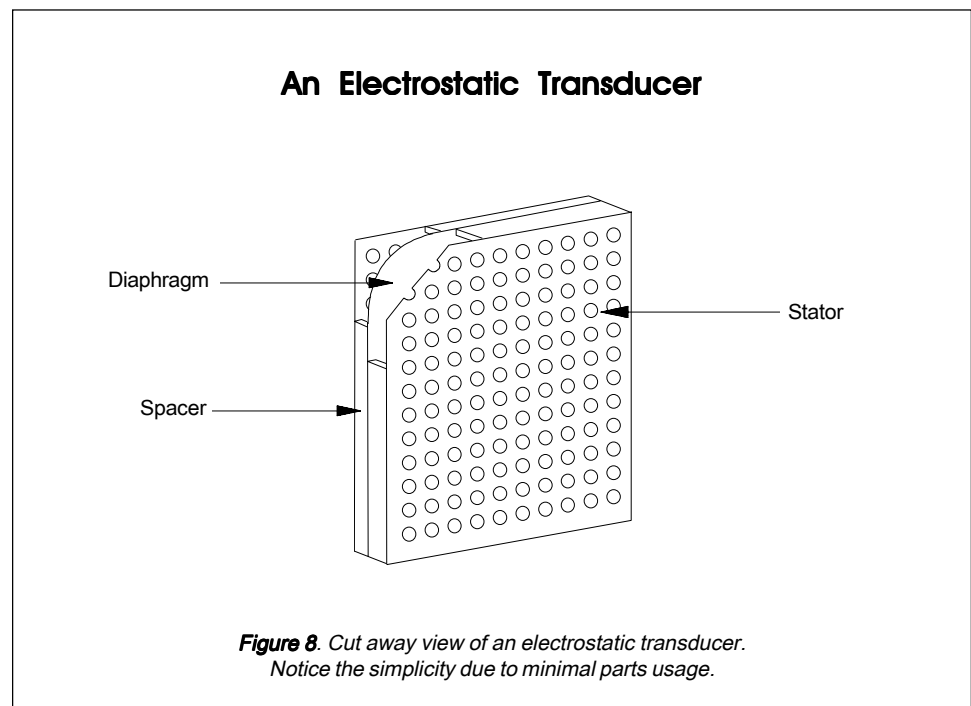

major contributor to the sonic purity of the electrostatic concept due to its exceptional linearity and low distortion.

Since the diaphragm of an electrostatic speaker is uniformly driven over its entire area, it can be extremely light and flexible. This allows it to be very responsive to transients, thus perfectly tracing the music signal. As a result, great delicacy, nuance and clarity is

possible. When you look at the problems of traditional electromagnetic drivers, you can easily see why this is so beneficial.

The cones and domes which are used in traditional electromagnetic drivers cannot be driven uniformly because of their design. Cones are driven only at the apex. Domes are driven at their perimeter. As a result, the rest of the

cone or dome is just "along for the ride". The basic concept of these drivers require that the cone or dome be perfectly rigid, damped and close to massless. Unfortunately these conditions are not available in our world today.

To make these cones and domes move, all electromagnetic drivers must use voice coils wound on formers, spider assemblies, and surrounds to keep the cone or dome in position (see *Figure 9*). These pieces, when combined with the high mass of the cone or dome materials used, make it an extremely complex unit with many weaknesses and potential for failure. These faults contribute to the high distortion products found in this type of driver and is a tremendous disadvantage when you are trying to change motion as quickly and as accurately as a loudspeaker must (40,000 times per second!).

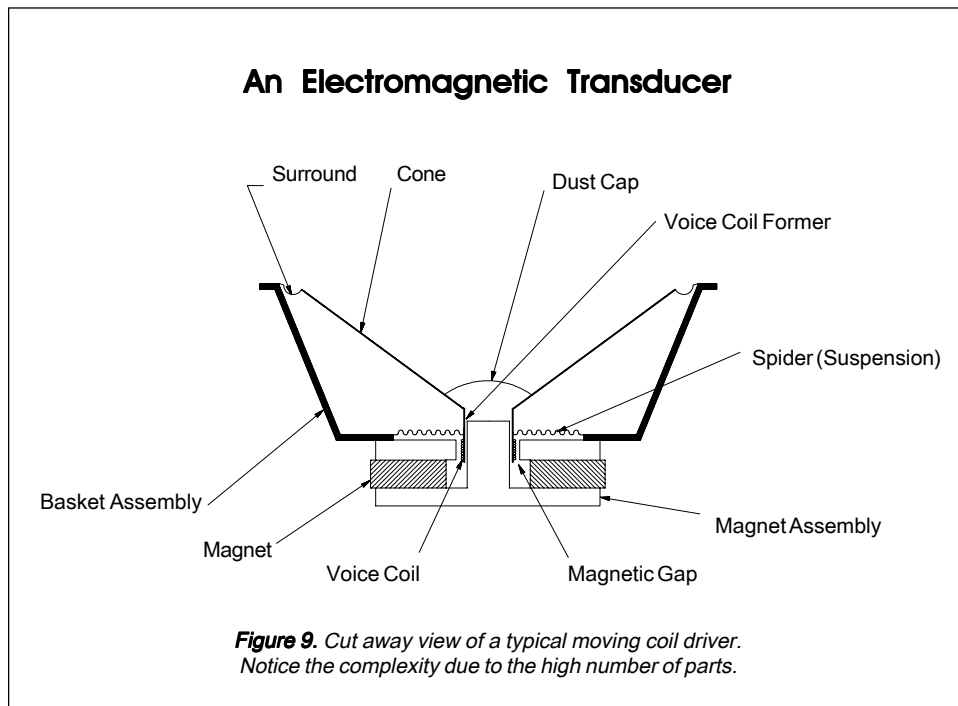

Martin-Logan Exclusives

1. Full Range Operation

The most significant advantage of Martin-Logan's exclusive transducer technology reveals itself when you look at examples of other loudspeaker products on the market today.

The MONOLITH III uses no crossover networks above 125 Hz because they are not needed. The MONOLITH III consists of a single, seamless electrostatic membrane reproducing all frequencies above 125 Hz simultaneously. How is this possible?

First we must understand that music is not composed of separate high, mid and low frequency pieces. In fact, music is comprised of a single complex waveform with all frequencies interacting simultaneously.

The electrostatic transducer of the Monolith essentially acts as an exact opposite of the microphones used to record the original event. A microphone, which is a single working element, transforms acoustic energy into an electrical signal that can be amplified or preserved by some type of storage media. The MONOLITH III's electrostatic transducer transforms electrical energy from your amplifier into acoustical energy. Due to the limitations of electromagnetic drivers, no single unit can reproduce the

full range of frequencies. Instead, these drivers must be designed to operate within narrow, fixed bandwidths of the frequency range and then combined electrically so that the sum of the parts equals the total signal. While nice in theory, we must deal with real-world conditions.

In order to use multiple drivers, a crossover network is enlisted to attempt

a division of the complex musical signal into the separate pieces (usually highs, mids, and lows) that each specific driver was designed to handle. Unfortunately, due to the phase relationships that occur within all crossover networks and during the acoustical recombination process, nonlinearities and severe degradation of the music signal takes place in the ear's most "critical zone". See *Figure 10*.

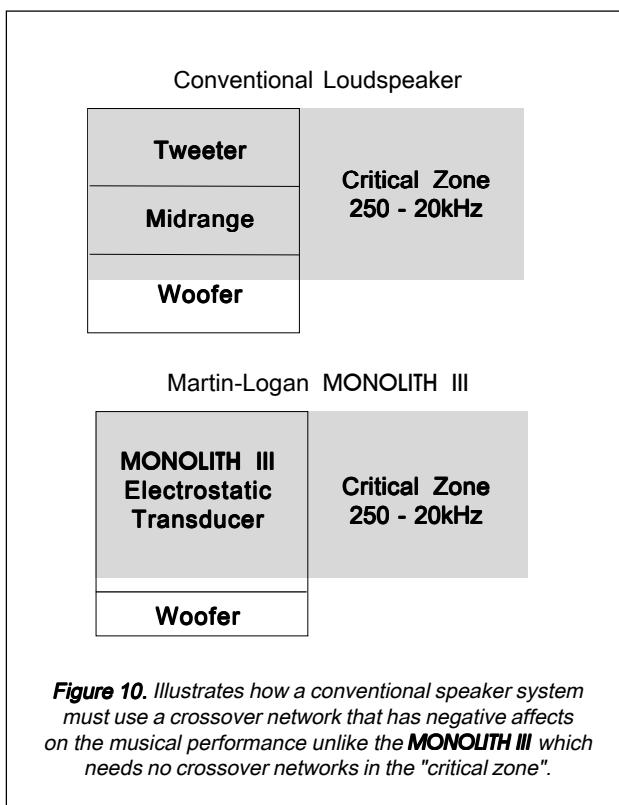

The MONOLITH III's electrostatic transducer can single-handedly reproduce all frequencies above 100 Hz simultaneously. So, you have, in one transducer, the ability to handle, in elegant simplicity, the critical frequencies above 100 Hz.

The crossover phase discontinuities that are associated with traditional tweeter, midrange, and woofer systems are eliminated. This results in a dramatic improvement in imaging and staging performance due to the minutely accurate phase relationship of the full-range panel wave launch.

2. Curvilinear Line Source

Since the beginning of Audio, achieving smooth dispersion has long been a problem for all loudspeaker designers. Large panel transducers present even more of a challenge because the larger the panel, the more directional the dispersion pattern becomes.

Full range electrostats have long been one of the most problematic transducers because they attain their full range capabilities via a large surface area. It looked as if they were in direct conflict to smooth dispersion and almost every attempt to correct this resulted in either poor dispersion or a serious compromise in sound quality.

After extensive research, Martin-Logan engineers discovered an elegantly simple solution to achieve a smooth pattern of dispersion without degrading sound quality. By curving the horizontal plane of the electrostatic transducer, a controlled horizontal dispersion pattern could be achieved, yet the purity of the almost massless electrostatic diaphragm remained uncompromised. After creating this technology, we developed the production capability to bring this technology out of the laboratory and into the market place.

You will find this proprietary Martin-Logan technology used in all of our products. It is one of the many reasons behind our reputation for high quality sound with practical usability. This is also why you see the unique "see through" cylindrical shape of all Martin-Logan products.

3. Hybrid Technology

When Martin-Logan introduced the Monolith back in 1982, it was the first company to commercially recognize the performance potential available by mating the air-moving capabilities of a dynamic woofer with the inherent speed and accuracy of an electrostatic panel.

Since then, refinements in the actual driver assemblies, crossover components, and materials used in the construction of our hybrid speakers have brought this concept to its full potential.

4. Vapor Deposited Film

The diaphragm material used in all Martin-Logan speakers employs an extremely sophisticated conductive surface that has been vapor deposited on the polymer surface at an atomic level. Copper oxide and palladium have been vaporized and electrostatically driven into the surface of the polymer film in a vacuum chamber. This process allows an optically transparent surface adding no mass to the diaphragm that is extremely uniform in its surface resistivity characteristics. This uniform surface resistivity controls the electrostatic charge on the diaphragm surface and regulates its migration. As a result, no discharging or "arcing" can occur.

5. Transducer Integrity

All Martin-Logan transducers begin with two pieces of high grade, cold rolled steel. The rear stator is manufactured from 16 gauge material while the front stator from 18 gauge. These steel pieces are then custom perforated and insulated with an exotic nylon composite coating. This proprietary coating insulates the stator to 3 times its actual needed working voltage and gives the Monolith a wide margin of safe operation. In addition to the electrical insulation properties, this coating also provides the Monolith with a durable, attractive finish that dampens the steel to prevent ringing. These pieces are then sandwiched with our exclusive vapor deposited diaphragm and spacers into a curved geometry and bonded together with aerospace adhesives whose strength exceeds that of welding.

When all of these various techniques are combined, we get a transducer that is attractive, durable, highly rigid, well dampened, and neutral.

Questions

Could my children, pets, or myself be shocked by the high-voltage present in the electrostatic panel?

No. High voltage with low current is not dangerous. As a matter of fact, the high-voltage present in our speakers is 10 times less than the static electricity that you generate when you take off a sweater. (About 30,000 volts!)

What size of an amplifier should I use with the Monoliths?

We recommend an amplifier with 100 to 200 watts per channel for most applications.

Do I need an amplifier with high current capability?

No. The Monolith's impedance characteristics do not require that a high current amplifier be used. However, it is important that the amplifier be stable operating into varying impedance loads.

Should I unplug my Monoliths during a thunderstorm?

Yes. Or before. It's a good idea to disconnect all of your audio/video components during stormy weather.

Will my electric bill go 'sky high' by leaving my speakers plugged in all the time?

No. A pair of Monoliths draw about 5 watts maximum.

Is there likely to be any interaction between the Monoliths and the television in my Audio/Video system?

Actually, there is less interaction between a television and an electrostatic speaker than between a television and a conventional system. The magnets in conventional speakers do interact with television tubes. However, we do recommend that you keep your speakers at least one foot away from the television because of the dynamic woofer they employ.

Will excessive smoke or dust cause any problems?

Exposure to excessive smoke or dust may potentially affect the performance of the electrostatic membrane. When not in use, you should unplug the speaker and cover with the plastic bags that the speakers were originally packed in.

If my child punctured the diaphragm with a pencil, stick, or similar item., how extensive would the damage to the speaker be?

You should probably replace the electrostatic element. However, this depends upon the extent of the damage.

Will exposure to sunlight affect the life or performance of the Monolith?

We recommend that you not place your Monoliths in direct sunlight as the ultraviolet (UV) rays from the sun can cause deterioration of the electrostatic membrane. However, small exposures to UV should not cause a problem.

Troubleshooting

No Output.

- Check that all your system components are turned on.
- Check your speaker wires and connections.
- Check all interconnecting cables.

Weak Output, Loss of Highs.

- Check the power cord. Is it properly connected to the speaker?
- If you are bi-amplifying, check your high frequency amplifier. Is it functioning properly?

Exaggerated Highs, Brightness.

- Check the toe-in of the speakers. Read *Room Placement* for more information.

Muddy Bass

- Check placement. Try moving the speakers closer to the back and side walls.
- Check the type of feet being used. Try attaching the coupling spikes.
- If you are using the IIIx CROSSOVER, adjust the bass contour controls until you get the desired response

Lack of Bass

- Check your speaker wires. Is the polarity correct?

Poor Imaging

- Check placement. Are both speakers the same distance from the walls? Do they have the same amount of toe-in? Try moving the speakers away from the back and side walls.
- Check the polarity of the speaker wires. Are they connected properly?

Popping and Ticking Sounds, Funny Noises

- These occasional noises are harmless and will not hurt your audio system or your speakers. All electrostatic speakers are guilty of making odd noises at one time or another.
- These noises may be caused by dirt and dust particles collecting on the speaker, by high humidity or by AC line fluctuations that may occur in your area.
- Dirt and dust may be vacuumed off with a brush attachment connected to your vacuum cleaner or you may blow them off with compressed air.
- DO NOT SPRAY ANY KIND OF CLEANING AGENT ON OR IN CLOSE PROXIMITY TO THEM.

Glossary

AC. Abbreviation for alternating current.

Active crossover. Uses active devices (transistors, IC's, tubes) and some form of power supply to operate.

Amplitude. The extreme range of a signal. Usually measured from the average to the extreme.

Arc. The visible sparks generated by an electrical discharge.

Bandwidth. The range of frequencies within a radiation band required to transmit a particular signal.

Bass. The lowest frequencies of sound.

Bi-Amplification. Uses an electronic crossover or line-level passive crossover and separate power amplifiers for the high and low frequency loudspeaker drivers.

Capacitance. That property of a capacitor which determines how much charge can be stored in it for a given potential difference between its terminals, measured in farads, by the ratio of the charge stored to the potential difference.

Capacitor. A device consisting of two or more conducting plates separated from one another by an insulating material and used for storing an electrical charge. Sometimes called a condenser.

Clipping. Distortion of a signal by its being chopped off. An overload problem caused by pushing an amplifier beyond its capabilities. The flat-topped signal has high levels of harmonic distortion which creates heat in a loudspeaker and is the major cause of loudspeaker component failure.

Crossover. An electrical circuit that divides a full bandwidth signal into the desired frequency bands for the loudspeaker components.

dB (decibel). A numerical expression of the relative loudness of a sound. The difference in decibels between two sounds is ten times the common logarithm of the ratio of their power levels.

DC. Abbreviation for direct current.

Diffraction. The breaking up of a sound wave caused by some type of mechanical interference such as a cabinet edge, grill frame, or other similar object.

Diaphragm. A thin flexible membrane or cone that vibrates in response to electrical signals to produce sound waves.

Distortion. Usually referred to in terms of total harmonic distortion (THD) which is the percentage of unwanted harmonics of the drive signal present with the wanted signal. Generally used to mean any unwanted change introduced by the device under question.

Driver. See transducer.

Dynamic Range. The range between the quietest and the loudest sounds a device can handle (often quoted in dB).

Efficiency. The acoustic power delivered for a given electrical input. Often expressed as decibels/watt/meter (dB/w/m).

ESL. Abbreviation for electrostatic loudspeaker.

Headroom. The difference, in decibels, between the peak and RMS levels in program material.

Hybrid. A product created by the marriage of two different technologies. Meant here as the combination of a dynamic woofer with an electrostatic transducer.

Hz (Hertz). Unit of frequency equivalent to the number of cycles per second.

Imaging. To make a representation or imitation of the original sonic event.

Impedance. The total opposition offered by an electric circuit to the flow of an alternating current of a single frequency. It is a combination of resistance and reactance and is measured in ohms. Remember that a speaker's impedance changes with frequency, it is not a constant

value.

Inductance. The property of an electric circuit by which a varying current in it produces a varying magnetic field that introduces voltages in the same circuit or in a nearby circuit. It is measured in henrys.

Inductor. A device designed primarily to introduce inductance into an electric circuit. Sometimes called a choke or coil.

Linearity. The extent to which any signal handling process is accomplished without amplitude distortion.

Midrange. The middle frequencies where the ear is the most sensitive.

Passive crossover. Uses no active components (transistors, IC's, tubes) and needs no power supply (AC, DC, battery) to operate. The crossover in a typical loudspeaker is of the passive variety. Passive crossovers consist of capacitors, inductors and resistors.

Phase. The amount by which one sine wave leads or lags a second wave of the same frequency. The difference is described by the term phase angle. Sine waves in

phase reinforce each other; those out of phase cancel.

Pink noise. A random noise used in measurements, as it has the same amount of energy in each octave.

Polarity. The condition of being positive or negative with respect to some reference point or object.

RMS. Abbreviation for root mean square. The effective value of a given waveform is its RMS value. Acoustic power is proportional to the square of the RMS sound pressure.

Resistance. That property of a conductor by which it opposes the flow of electric current, resulting in the generation of heat in the conducting material, usually expressed in ohms.

Resistor. A device used in a circuit primarily to provide resistance.

Resonance. The effect produced when the natural vibration frequency of a body is greatly amplified by reinforcing vibrations at the same or nearly the same frequency from another body.

Sensitivity. Volume of sound delivered for a given electrical input.

Stator. The fixed part forming the

reference for the moving diaphragm in a planar speaker.

THD. Abbreviation for total harmonic distortion. (See Distortion.)

TIM. Abbreviation for transient intermodulation distortion. (See Distortion.)

Transducer. Any of various devices that transmit energy from one system to another, sometimes one that converts the energy in form. Loudspeaker transducers convert electrical energy into mechanical motion.

Transient. Applies to that which lasts or stays but a short time. A change from one steady-state condition to another.

Transmit. To cause sound to pass through air or some other medium.

Tweeter. A small drive unit designed to produce only high frequencies.

Wavelength. The distance measured in the direction of progression of a wave, from any given point characterized by the same phase.

White noise. A random noise used in measurements, as it has the same amount of energy at each frequency.

Woofers. A drive unit operating in the bass frequencies only. Drive units in two-way systems are not true woofers but are more accurately described as being mid/bass drivers.

MARTIN·LOGAN, LTD.
THE ELECTROSTATIC TECHNOLOGY

2001 delaware street, p.o. box 741, lawrence, kansas 66044, phone: 913.749.0133, fax: 913.749.5320

© 1989 Martin-Logan Ltd. All rights reserved.