

HELOS™ 10

u s e r ' s m a n u a l

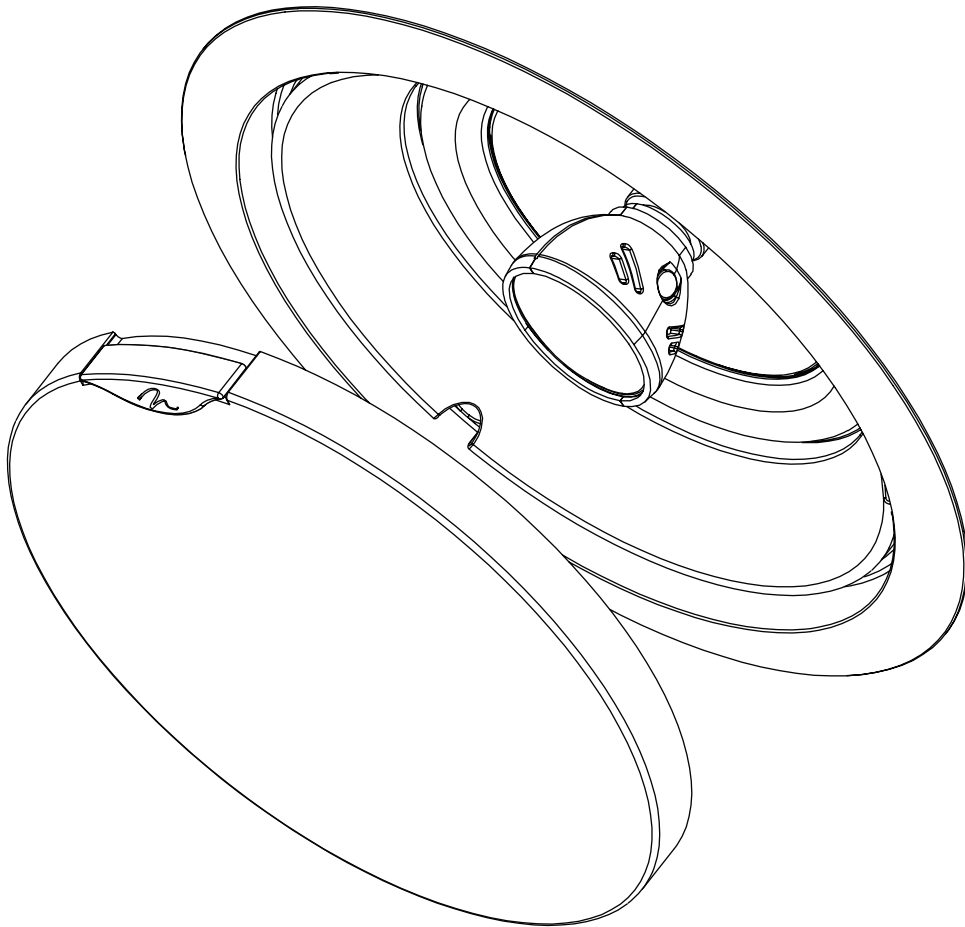

MARTIN LOGAN®
the loudspeaker technology company

CONTENTS AND INTRODUCTION





Contents

Contents and Introduction	2
Contents	
Introduction	
Placement	3
Installation	4
Painting and Customizing	8
Painting the Speaker Frame	
Painting the Speaker Grill	
Removing the Logo Badge	
Frequently Asked Questions and Troubleshooting	9
General Information	10
Specifications	
Warranty and Registration	
Serial Number	
Service	
Glossary of Audio Terms	11

Content Check List

You will find the following items enclosed for your new MartinLogan loudspeaker. Should you require assistance please call our service department at (785) 749-0133.

- ___ Installation Template
- ___ Grill Cover
- ___ Paint Shield
- ___ User's Manual
- ___ Warranty Registration Card

	The lightning bolt flash with arrowhead symbol within an equilateral triangle is intended to alert the user to the presence of uninsulated "dangerous voltage" within the product's enclosure that may be of sufficient magnitude to constitute a risk of electric shock.
	The exclamation point within an equilateral triangle is intended to alert the user to the presence of important operating and maintenance (servicing) instructions in the literature accompanying the appliance.
	The fire within an equilateral triangle is intended to alert the user to the potential of creating a fire hazard if they do not follow the instructions.
	The dollar sign within an equilateral triangle is intended to alert the user that they run the risk of causing damage that could be potentially expensive to repair if they don't follow the instructions.

Introduction

Congratulations! You have invested in a new world of high performance audio!

The MartinLogan Helos 10 represents the culmination of an intensive, dedicated group research program directed toward establishing a world class reference monitor utilizing leading-edge technology, without compromising durability, reliability, craftsmanship or aesthetic design. The materials in your new Helos 10 speaker are of the highest quality and will provide years of enduring enjoyment and deepening respect.

This User's Manual will explain in detail the operation of your Helos 10 speaker and the philosophy applied to its design. A clear understanding of your speaker will insure that you obtain maximum performance and pleasure from this most exacting transducer. It has been designed and constructed to give you years of trouble-free listening enjoyment.

	In accordance with the European Union WEEE (Waste Electrical and Electronic Equipment) directive effective August 13, 2005, we would like to notify you that this product may contain regulated materials which upon disposal, according to the WEEE directive, require special reuse and recycling processing.
	For this reason MartinLogan has arranged with our distributors in European Union member nations to collect and recycle this product at no cost to you. To find your local distributor please contact the dealer from whom you purchased this product, email info@martinlogan.com or visit the distributor locator at www.martinlogan.com .
	Please note, only this product itself falls under the WEEE directive. When disposing of packaging and other related shipping materials we encourage you to recycle these items through the normal channels.

	WARNING! <ul style="list-style-type: none">• Refer servicing to a qualified technician.• To prevent fire or shock hazard, do not expose this module to moisture.• Turn amplifier off should any abnormal conditions occur.• Do not drive speaker beyond its rated power.
---	--

PLACEMENT

When choosing placement for the Helos 10, follow these simple tips:

— Place the Helos 10 a minimum of 12" (30cm) from any wall.

— Place the front and center channels between 7 to 10 feet (214 to 305cm) from the primary listening position.

— Point the tweeter of all speakers towards the primary listening position.

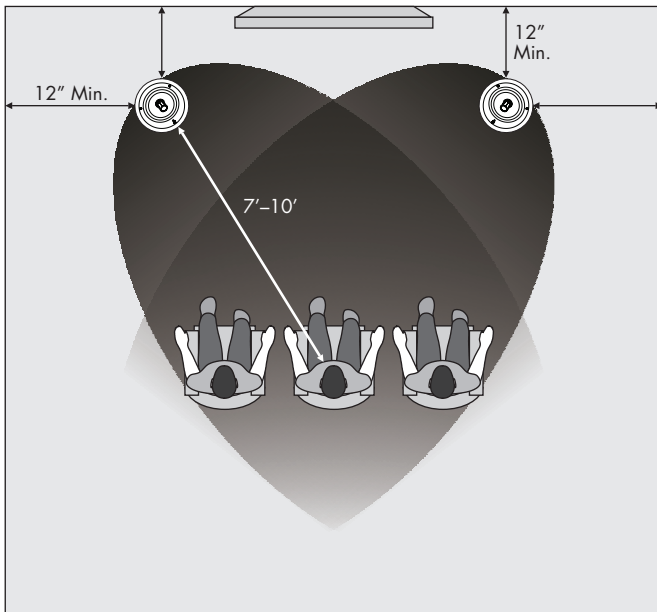

Figure 1. 2-channel installation.

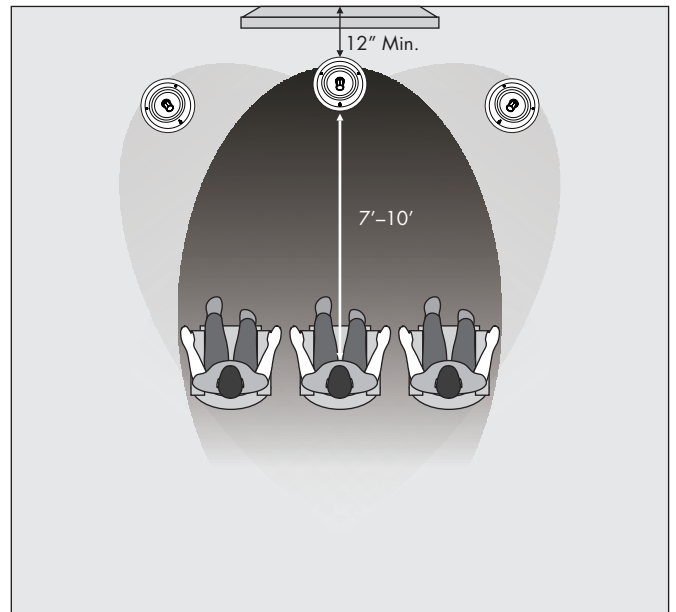

Figure 2. Adding a center channel to create a 3-channel installation.

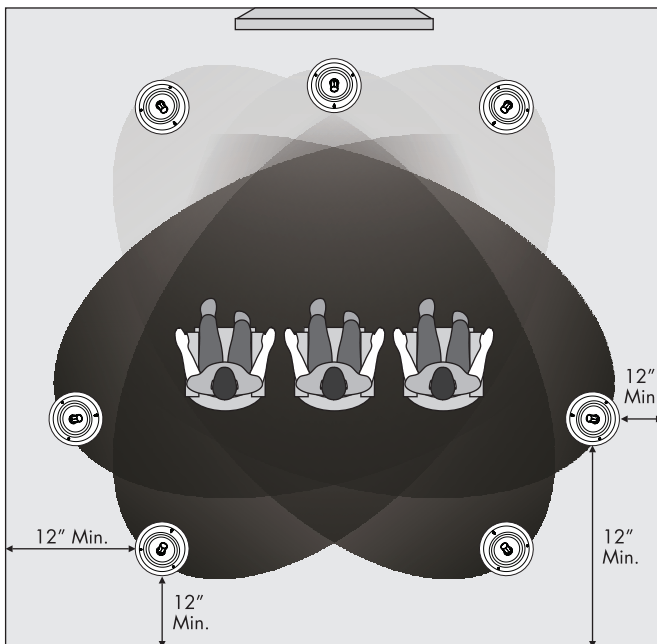

Figure 3. Adding surround channels to create a 5- or 7-channel installation.

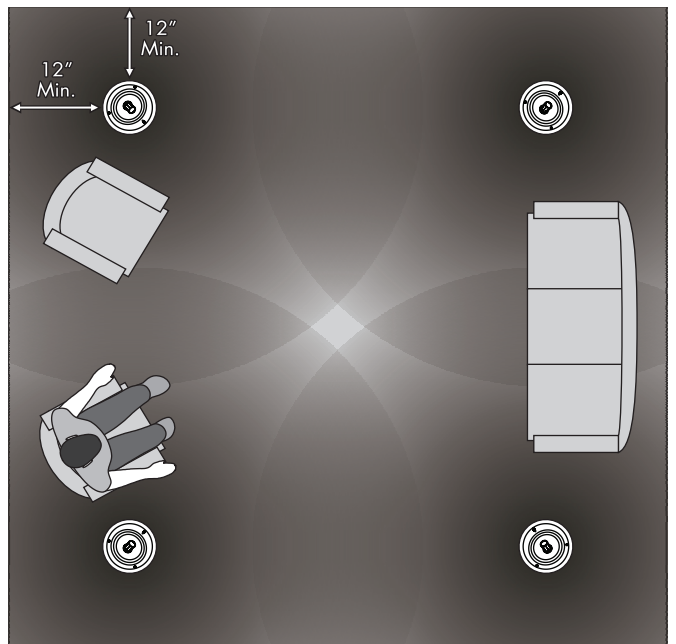

Figure 4. Using the Helos 10 for distributed audio.

INSTALLATION

NOTE: These instructions must be carefully followed to assure that your Helos 10 is safely installed. Study them thoroughly before installing your Helos 10.

NOTE: The following instructions assume the mounting surface is of standard wood frame and standard sheet rock construction. If you wish to mount the Helos 10 to another type of material, you should consult a bonded contractor.



Warning! Before installing check local building codes to verify compliance with local regulations.



Warning! Before installing check for obstructions behind the drywall (electrical, plumbing and other fixtures). To do this make a small hole, cutting at a 45° angle (this will make the hole easier to patch if obstructions are found). **Only cut the mounting hole after you have verified there are no obstructions behind the ceiling.**



Required tools (not included):

- Stud finder
- Sharp pencil or pen
- Dry wall knife/saw
- Wire strippers
- Electric drill (with clutch)
- 2-inch long #2 Phillips Driver bit
- Tape measure
- Push Pin

Depth required above ceiling surface:

4.5" (11.4cm)

Required ceiling opening (includes tolerance):

8.35" (21.2cm)

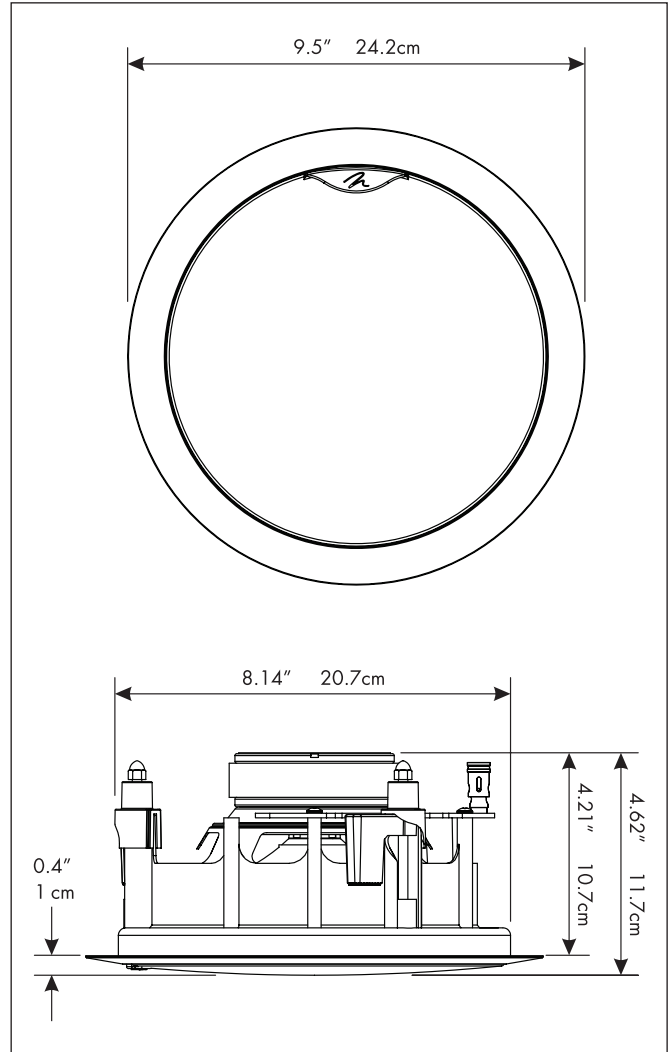

Figure 5. Dimensions of the Helos 10

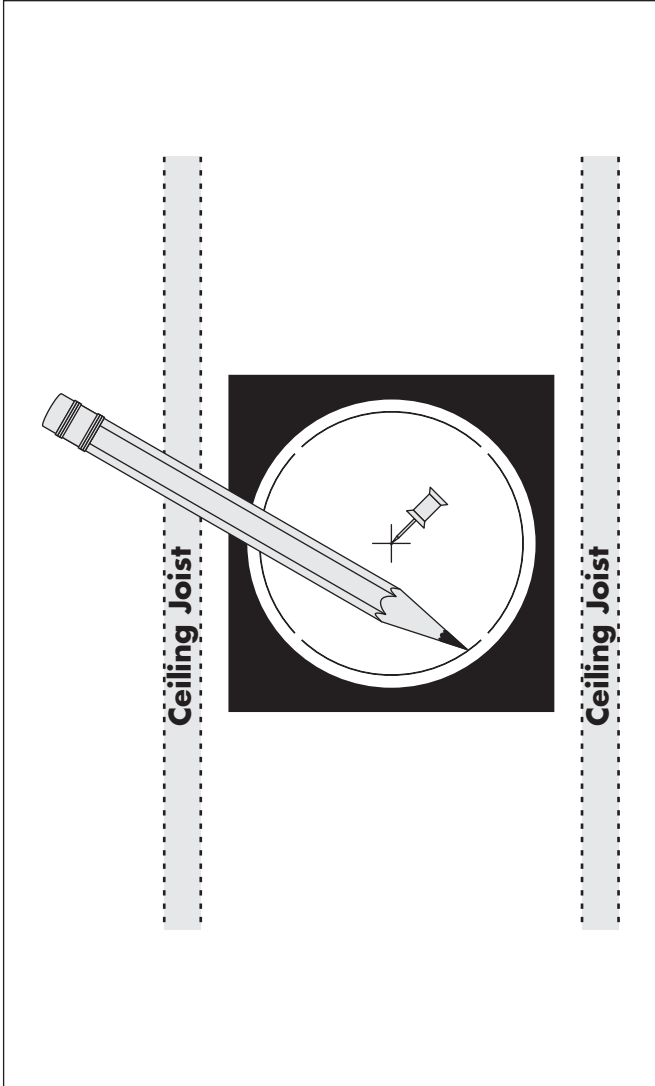

Figure 6. Installation steps 1–3.

- 1 Using a stud finder, locate the final speaker position between ceiling joists.

 **WARNING!** Absolutely no part of the template should overlap a joist.

- 2 Insert a push pin in the template center.
- 3 Mark cutout through slots in template. Remove Template.

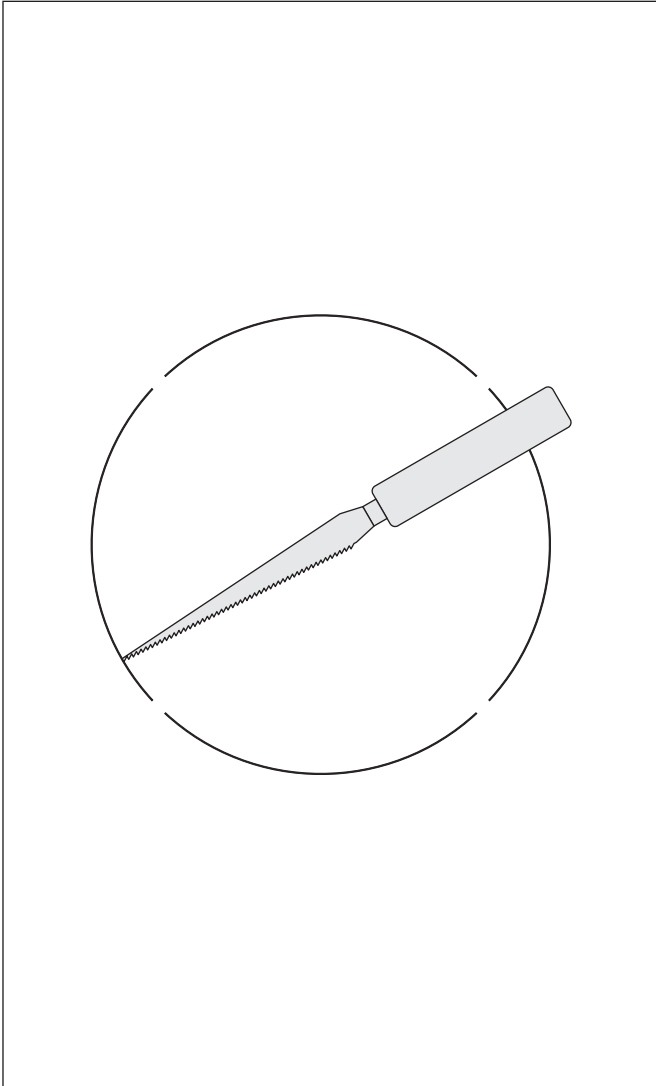

Figure 7. Installation step 4.

- 4 Use a dry wall knife/saw to cut out the opening.

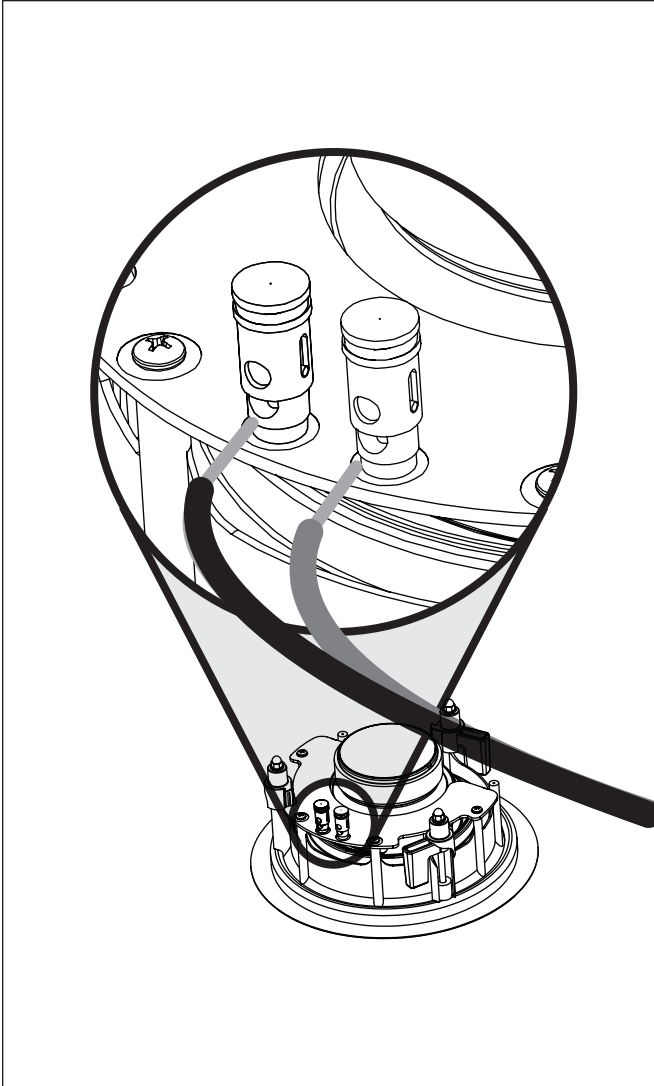

Figure 8. Connecting the Helos 10.

- 5 Connect speaker cable. Be consistent when connecting speaker leads to the terminals on the Helos 10. Take great care to assign the same color to the (+) terminal on both the speaker and the amplifier.



WARNING! Turn your amplifier off before making or breaking any signal connections!

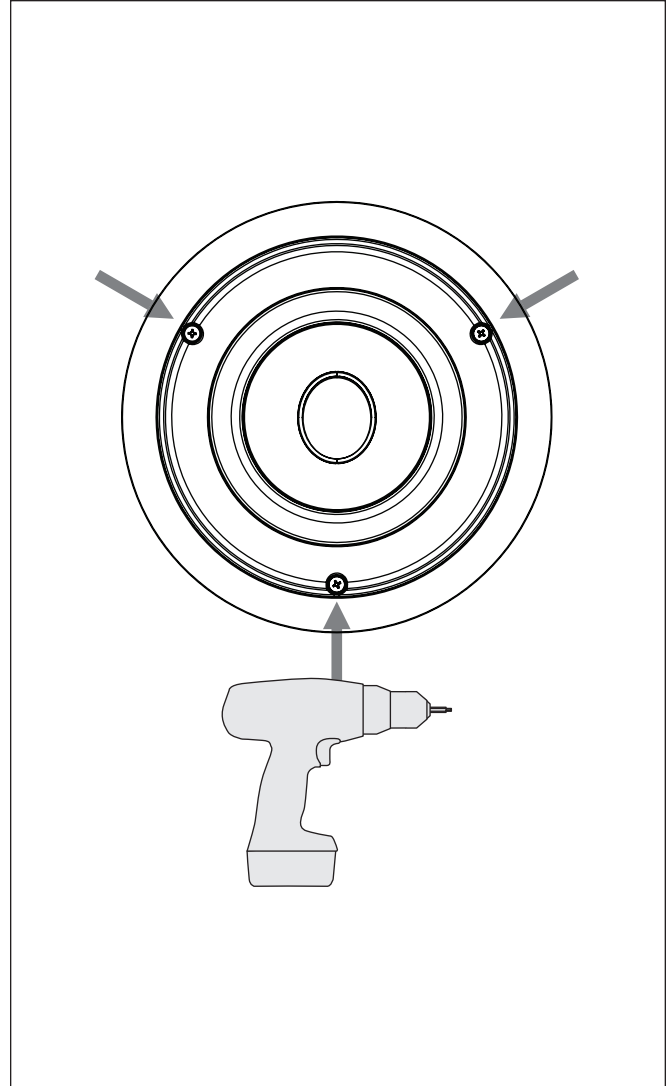

Figure 9. Installation step 6-7.

- 6 Place speaker in hole.
- 7 Use a 2-inch long #2 Phillips driver and an electric drill to lock all 3 mounting locks in place. Use a low clutch setting on the drill.

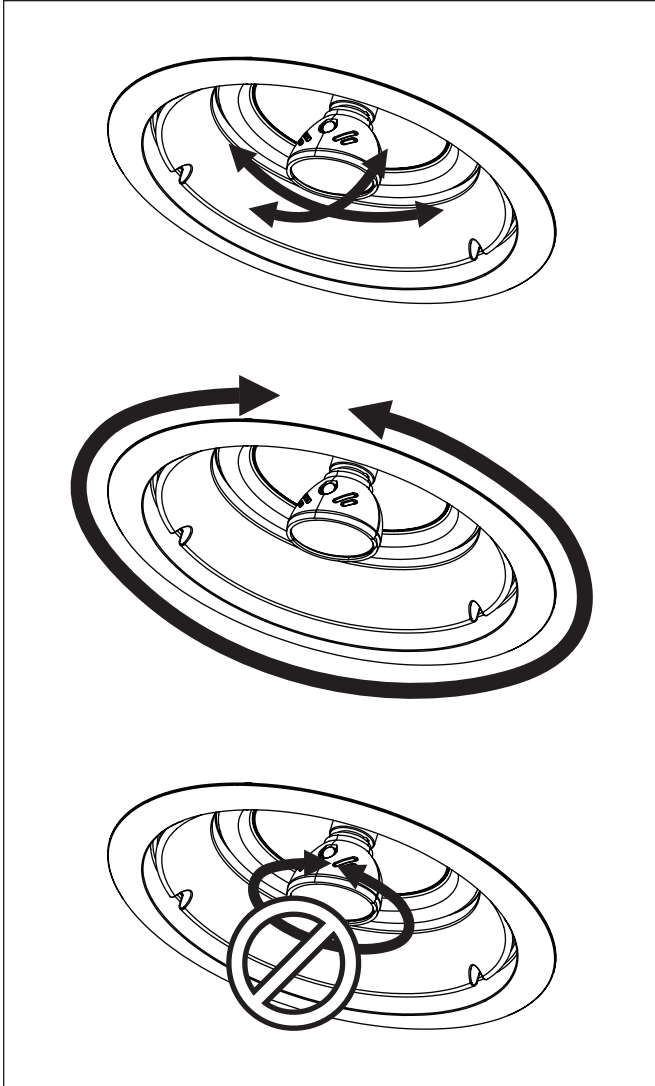

Figure 10. Installation step 8.

- 8 Gently pivot the tweeter stem to point towards the primary listening position. To rotate the speaker, rotate the entire speaker assembly. **DO NOT** rotate the tweeter stem.

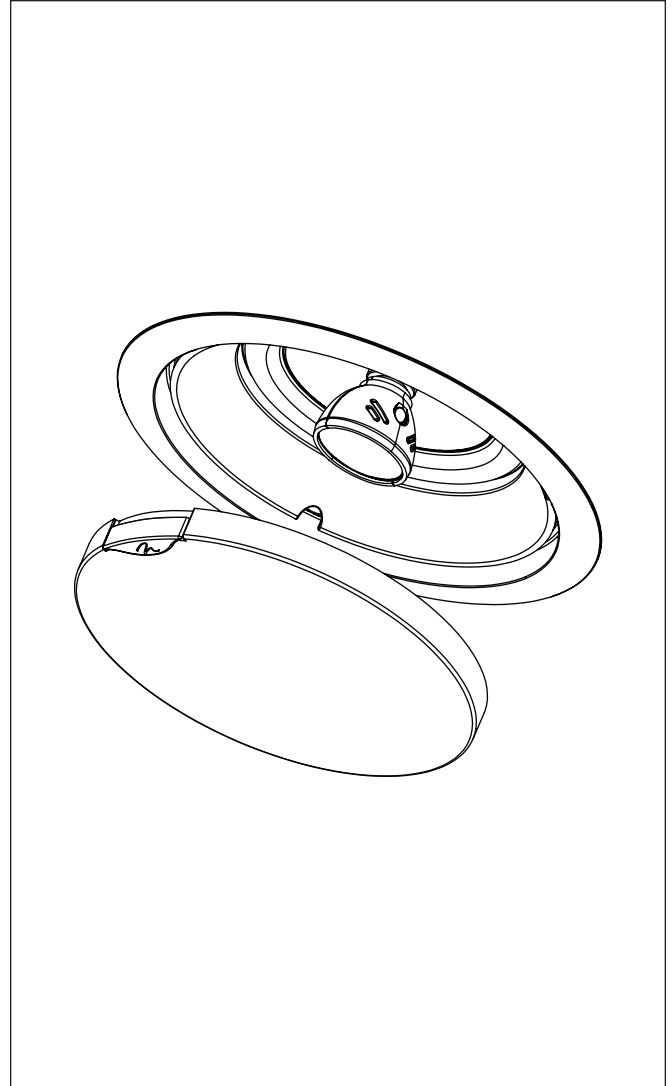

Figure 11. Installation step 9.

- 9 Gently press the grill cover into place.

CUSTOMIZING AND PAINTING

Painting the Speaker Frame

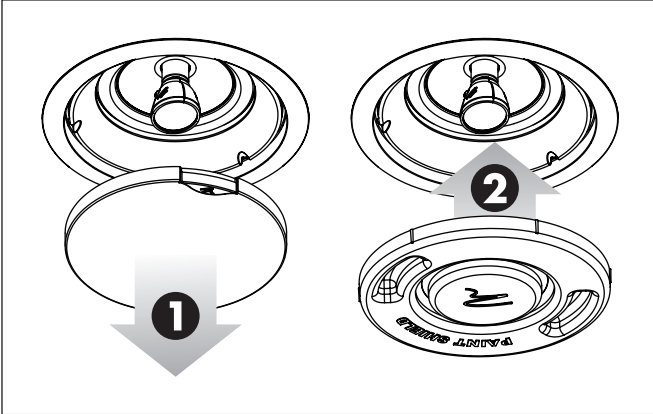

Figure 12. Painting the speaker frame.

NOTE: The Helos 10 can be either painted in place or removed from the ceiling for painting.

IMPORTANT! Do not paint the rear of the speaker or the surface behind the grill.

- 1 Remove the grill from the Helos 10 (see figure 12).
- 2 Press the paint shield into place (see figure 12).
- 3 In a well ventilated area paint the Helos 10 speaker frame, allowing frame to dry completely between coats.

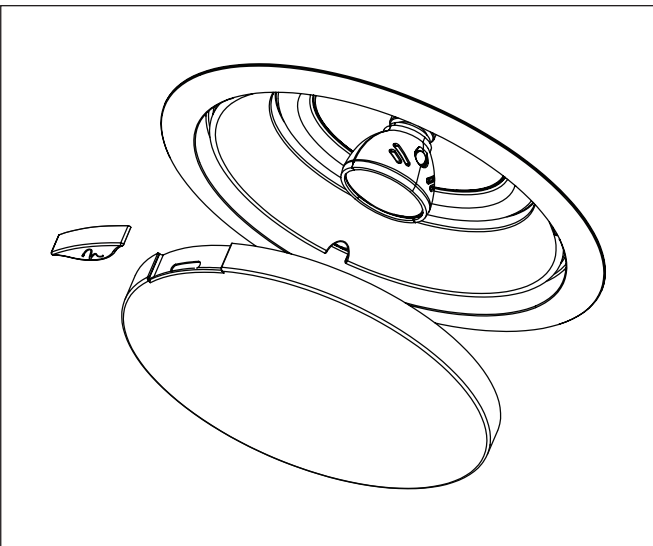

Figure 14. Removing the logo badge.

Painting the Speaker Grill

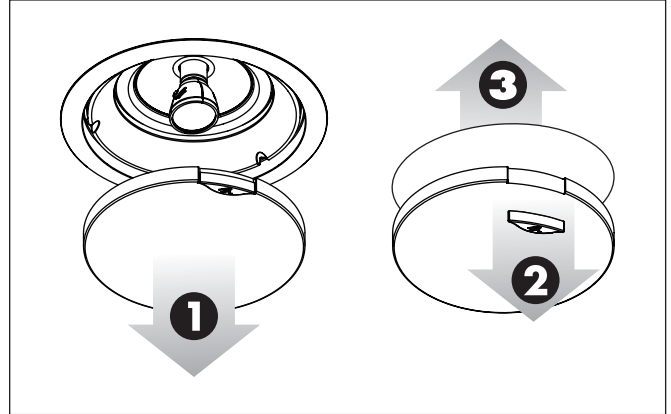

Figure 13. Painting the speaker grill.

IMPORTANT! The grill must be removed from the speaker before painting.

IMPORTANT! The scrim must be removed before painting the grill.

IMPORTANT! The logo badge must be removed before painting the grill.

- 1 Remove the grill from the Helos 10 (see figure 13).
- 2 Remove the logo badge (see below).
- 3 A protective scrim is attached to the back of the grill with low-tack adhesive. Remove this scrim by gently pulling it away from the grill cover (see figure 13).
- 4 Paint the grill being careful not to plug the holes. For best results use a spray rather than a brush. Allow paint to completely dry before proceeding.
- 5 Gently press the scrim and logo badge back into place before reinstalling the speaker grill.

Removing the Logo Badge

The MartinLogan logo badge on the Helos 10 is removable. To do this, gently depress the tabs on the back of the logo badge (see figure 14).

FREQUENTLY ASKED QUESTIONS AND TROUBLESHOOTING

Frequently Asked Questions

How do I clean my speakers?

Just use a dust free cloth or a soft brush to remove the dust from your speakers. We recommend a specialty cloth (available at the Xtatic shop at www.martinlogan.com) that cleans your speakers better than anything else we have tried. **Do not spray any kind of cleaning agent on or in close proximity to the drivers.**

What size amplifier should I use?

We recommend an amplifier with 100 watts per channel for most applications. Probably less would be adequate when used in home theater where a subwoofer is employed.

Could you suggest a list of suitable electronics and cables that would be ideal for MartinLogan speakers?

The area of electronics and cable choice is probably the most common type of question that we receive. It is also the most subjective. We have repeatedly found that brands that work well in one setup will drive someone else nuts in another. We use many brands with great success. Again, we have no favorites; we use electronics and cables quite interchangeably. We would suggest listening to a number of brands—and above all else—trust your ears. Dealers are always the best source for information when purchasing additional audio equipment or cables and will be well versed in the subject of special safety requirements for in-wall cable.

Will exposure to sunlight affect the life or performance of my speakers?

We recommend that you not place any loudspeaker in direct sunlight. The ultraviolet (UV) rays from the sun can cause deterioration of grill cloth, speaker cones, etc. Small exposures to UV will not cause a problem. In general, the filtering of UV rays through glass will greatly reduce the negative effects.

Troubleshooting

Output

- Check that all your system components are turned on.
- Check your speaker wires and connections.
- Check all interconnecting cables.

GENERAL INFORMATION

Specifications

System Frequency Response

47–20,000 Hz \pm 3 dB

Sensitivity

89 dB/2.83 volts/meter (mounted in ceiling)

Impedance

4 ohms

Crossover Frequency

2800 Hz

Components

Custom air core coils, polyester capacitors

Binding Posts

Push style binding posts, accommodates wire up to 5AWG

Tweeter Type

1" (2.5cm) neodymium soft dome

Woofer Type

6.5" (16.5cm) high rigidity aluminum cone with extended throw drive assembly, thermal protection

Power Handling

100 watts

Weight

4.5 lbs. each (2 kg)

Overall Size

9.5" inches W \times 4.62" inches D
(20.7cm W \times 11.7cm D)

Required ceiling opening (including tolerance)

8.35" (21.2cm)

Projection from wall surface

0.4" (1cm)

Depth required behind wall surface

4.5" (11.4cm)

Warranty and Registration

Your Helos 10 speaker is provided with an automatic Limited 90 Day Warranty coverage.

You have the option, at no additional charge, to receive a Limited 5 Year Warranty coverage. To obtain the Limited 5 Year Warranty coverage you need to complete and return the Certificate of Registration, included with your speakers, and provide a copy of your dealer receipt to MartinLogan within 30 days of purchase.

For your convenience MartinLogan also offers online warranty registration at www.martinlogan.com.

MartinLogan may not honor warranty service claims unless we have a completed Warranty Registration on file!

If you did not receive a Certificate of Registration with your new Helos 10 speaker, you cannot be assured of having received new units. If this is the case, please contact your authorized MartinLogan dealer.

Serial Number

The Helos 10's serial number is located on the back of the speaker and also on the product's shipping carton.

Service

Should you be using your MartinLogan product in a country other than the one in which it was originally purchased, we ask that you note the following:

- 1 The appointed MartinLogan distributor for any given country is responsible for warranty servicing only on units distributed by or through it in that country in accordance with its applicable warranty.
- 2 Should a MartinLogan product require servicing in a country other than the one in which it was originally purchased, the end user may seek to have repairs performed by the nearest MartinLogan distributor, subject to that distributor's local servicing policies, but all cost of repairs (parts, labor, transportation) must be borne by the owner of the MartinLogan product.
- 3 If, after owning your speakers for six months, you relocate to a country other than the one in which you purchased your speakers, your warranty may be transferable. Contact MartinLogan for details.

GLOSSARY OF AUDIO TERMS

AC. Abbreviation for alternating current.

Active crossover. Uses active devices (transistors, ICs, tubes) and some form of power supply to operate.

Amplitude. The extreme range of a signal. Usually measured from the average to the extreme.

Arc. The visible sparks generated by an electrical discharge.

ATF. The abbreviation for advanced thin film.

Bass. The lowest frequencies of sound.

Bi-Amplification. Uses an electronic crossover, or line-level passive crossover, and separate power amplifiers for the high and low frequency loudspeaker drivers.

Capacitance. That property of a capacitor which determines how much charge can be stored in it for a given potential difference between its terminals, measured in farads, by the ratio of the charge stored to the potential difference.

Capacitor. A device consisting of two or more conducting plates separated from one another by an insulating material and used for storing an electrical charge. Sometimes called a condenser.

Clipping. Distortion of a signal by its being chopped off. An overload problem caused by pushing an amplifier beyond its capabilities. The flat-topped signal has high levels of harmonic distortion which creates heat in a loudspeaker and is the major cause of loudspeaker component failure.

CLS. The abbreviation for curvilinear line source.

Crossover. An electrical circuit that divides a full bandwidth signal into the desired frequency bands for the loudspeaker components.

dB (decibel). A numerical expression of the relative loudness of a sound. The difference in decibels between two sounds is ten times the Base 10 logarithm of the ratio of their power levels.

DC. Abbreviation for direct current.

Diffraction. The breaking up of a sound wave caused by some type of mechanical interference such as a cabinet edge, grill frame or other similar object.

Diaphragm. A thin flexible membrane or cone that vibrates in response to electrical signals to produce sound waves.

Distortion. Usually referred to in terms of total harmonic distortion (THD) which is the percentage of unwanted harmonics of the drive signal present with the wanted signal. Generally used to mean any unwanted change introduced by the device under question.

Driver. See transducer.

Dynamic Range. The range between the quietest and the loudest sounds a device can handle (often quoted in dB).

Efficiency. The acoustic power delivered for a given electrical input. Often expressed as decibels/watt/meter (dB/w/m).

ESL. The abbreviation for electrostatic loudspeaker.

Headroom. The difference, in decibels, between the peak and RMS levels in program material.

Hybrid. A product created by the marriage of two different technologies. Meant here as the combination of a dynamic woofer with an electrostatic or ATF transducer.

Hz (Hertz). Unit of frequency equivalent to the number of cycles per second.

Imaging. To make a representation or imitation of the original sonic event.

Impedance. The total opposition offered by an electric circuit to the flow of an alternating current of a single frequency. It is a combination of resistance and reactance and is measured in ohms. Remember that a speaker's impedance changes with frequency, it is not a constant value.

Inductance. The property of an electrical circuit by which a varying current in it produces a varying magnetic field that introduces voltages in the same circuit or in a nearby circuit. It is measured in henrys.

Inductor. A device designed primarily to introduce inductance into an electrical circuit. Sometimes called a choke or coil.

Linearity. The extent to which any signal handling process is accomplished without amplitude distortion.

Midrange. The middle frequencies where the ear is the most sensitive.

NAC. The abbreviation for natural ambience compensation.

Passive crossover. Uses no active components (transistors, ICs, tubes) and needs no power supply (AC, DC, battery) to operate. The crossover in a typical loudspeaker is of the passive variety. Passive crossovers consist of capacitors, inductors and resistors.

Phase. The amount by which one sine wave leads or lags a second wave of the same frequency. The difference is described by the term phase angle. Sine waves in phase reinforce each other; those out of phase cancel.

Pink noise. A random noise used in measurements, as it has the same amount of energy in each octave.

Polarity. The condition of being positive or negative with respect to some reference point or object.

RMS. Abbreviation for root mean square. The effective value of a given waveform is its RMS value. Acoustic power is proportional to the square of the RMS sound pressure.

Resistance. That property of a conductor by which it opposes the flow of electric current, resulting in the generation of heat in the conducting material, usually expressed in ohms.

Resistor. A device used in a circuit to provide resistance.

Resonance. The effect produced when the natural vibration frequency of a body is greatly amplified by reinforcing vibrations at the same or nearly the same frequency from another body.

Sensitivity. The volume of sound delivered for a given electrical input.

Stator. The fixed part forming the reference for the moving diaphragm in a planar speaker.

THD. The abbreviation for total harmonic distortion. (See Distortion)

TIM. The abbreviation for transient intermodulation distortion.

Transducer. Any of various devices that transmit energy from one system to another, sometimes one that converts the energy in form. Loudspeaker transducers convert electrical energy into mechanical motion.

Transient. Applies to that which lasts or stays but a short time. A change from one steady-state condition to another.

Tweeter. A small drive unit designed to reproduce only high frequencies.

Wavelength. The distance measured in the direction of progression of a wave, from any given point characterized by the same phase.

White noise. A random noise used in measurements, as it has the same amount of energy at each frequency.

Woofers. A drive unit operating in the bass frequencies only. Drive units in two-way systems are not true woofers but are more accurately described as being mid/bass drivers.



MARTIN LOGAN[®]
the loudspeaker technology company