

# User's Manual

## The Aeries Speaker System

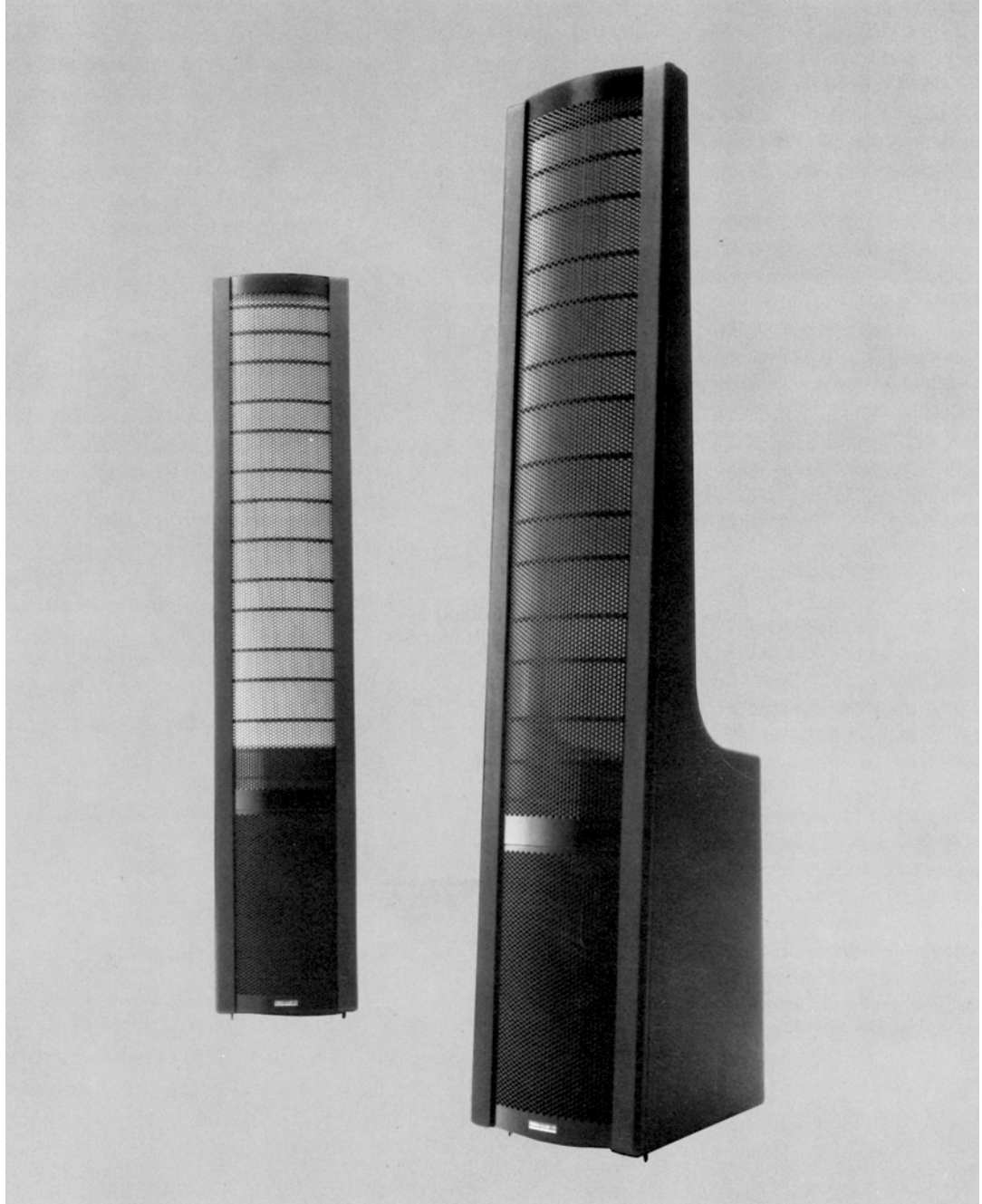

# Important

---

Your Aeries speakers are provided with an automatic Limited 90 Day Warranty coverage.

You have the option, at no additional charge, to receive Limited 3 Year Warranty coverage. To obtain Limited 3 Year Warranty coverage you need only complete and return the Certificate of Registration that was included with your speakers along with a copy of your invoice to Martin-Logan, within 30 days of purchase.

***Martin-Logan may not honor warranty service claims unless we have a completed Warranty Registration card on file!***

Should you be using your Martin-Logan product in a country other than the one in which it was originally purchased, we ask that you note the following:

- 1) The appointed Martin-Logan distributor for any given country is responsible for warranty servicing only on units distributed by or through it in that country in accordance with its applicable warranty.
- 2) Should a Martin-Logan product require servicing in a country other than the one in which it was originally purchased, the end user may seek to have repairs performed by the nearest Martin-Logan distributor, subject to that distributor's local servicing policies, but all cost of repairs (parts, labor, transportation) must be born by the owner of the Martin-Logan product.
- 3) If you relocate to a country, other than where you purchased your Martin-Logan's, after owning your speakers for 6 months your warranty may be transferable. Contact Martin-Logan for details.

If you did not receive a Certificate of Registration with your Aeries speakers you cannot be assured of having received new units. If this is the case, please contact your Authorized Martin-Logan dealer.

# Contents

---

---

Introduction	3
Installation in Brief	4
The Electrostatic Concept	5
History	6
Martin-Logan Exclusives	8
Operation	10
Room Acoustics	12
Placement	16
Questions	18
Troubleshooting	19
Recommended Music	20
Aeries Specifications	21
Glossary	22

---

# Introduction

---

Congratulations, you have invested in one of the world's premier loudspeaker systems!

The result of cumulative technology gleaned from twelve previous Research and Development projects, the Aeries represents the latest developments in Electrostatic and Hybrid loudspeaker technology.

Combining our proprietary curvilinear electrostatic transducer with a compact, but powerful subwoofer, we have designed a product, in one package, that reproduces music with uncompromised electrostatic clarity and deep extended bass, yet takes up little more than one square foot of floor space.

All materials in your new Aeries speakers are of the highest quality to provide years of enduring enjoyment and deepening respect. The cabinetry is constructed from a special high-density hardwood powderboard for structural integrity and is finished with a durable and attractive matte surface finish.

Through rigorous testing, the curvilinear electrostatic panel has proven itself to be one of the most durable and reliable transducers available today. Fabricated from a specially tooled, high-grade steel, the panel is then coated with a special high dielectric compound that is applied via a proprietary electrostatic deposition process.

This panel assembly houses a membrane 0.0005 of an inch thick! Ruggedly constructed and insulated, as much as 200 watts of continuous power has driven the Aeries energized diaphragm into massive excursions with no deleterious effects.

We know you are anxious to listen to your new speakers. So, to speed you along, we have provided an **Installation in Brief** section ahead of the detailed descriptive information contained in this manual.

Please read and follow these instructions as you initially connect your Aeries speakers into your system. These instructions are important and will prevent you from experiencing any delay, frustration, or system damage which might occur in a trial-and-error procedure.

The other sections of your **User's Manual** will explain in detail the operation of your Aeries speakers and the philosophy applied to their design. A clear understanding of your speakers will insure that you obtain maximum performance and pleasure from this most exacting transducer.

Happy Listening!

# Installation in Brief

---

We know you are eager to hear your new Aeries loudspeakers, so this section is provided to allow fast and easy set up. Once you have them operational, please take the time to read, in depth, the rest of the information in this manual. It will give you perspective on how to obtain the best possible performance from your system.

If you should experience any difficulties in the set-up or operation of your Aeries speakers please refer to the **Room Acoustics, Placement** or **Operation** section of this manual.

Should you encounter a persistent problem that cannot be resolved, please contact your Authorized Martin-Logan dealer. He will provide you with the appropriate technical analysis to alleviate the situation.

## Step 1: Unpacking

Remove your new Aeries speakers from their packing.

## Step 2: Placement

Place the front of each Aeries two feet from the wall behind the speakers and angle them slightly toward your listening area. This is a good place to start. Please see the **Placement** section of this manual for more details.

## Step 3: Power Connection (AC)

Martin-Logan speakers require AC power to energize their electrostatic cells. Using the AC power cords provided, plug them in, making sure that you have made a firm connection to the wall outlet. Extension cords may be used, if necessary, since the power requirement of the Aeries is extremely small.

### **WARNING !**

*Turn your amplifier off before making or breaking any signal connections!*

## Step 4: Signal Connection

Use the best speaker cables you can! Higher quality cables, available from your specialty dealer, are recommended and will give you superior performance! Spade connectors are suggested for optimum contact and ease of installation.

Attach your speaker cables to the **Signal Input** section on the rear panel of each Aeries. Be consistent when connecting speaker leads to the terminals on the back of the Aeries: take great care to assign the same color to the (+) terminal on both the left and right channels. If bass is nonexistent and you cannot discern a tight, coherent image, you may need to reverse the (+) and (-) leads on one side to bring the system into proper polarity. For optional Bi-Wiring instructions, turn to the **Operations** section of this manual for proper set-up of the Aeries system.

## Step 5: Listen and Enjoy!

# The Electrostatic Concept

How can sound be reproduced by something that you are able to see through? Electrostatic energy makes this possible.

Where the world of traditional loudspeaker technology deals with cones, domes, diaphragms and ribbons that are moved with magnetism, the world of electrostatic loudspeakers deals with charged electrons attracting and repelling each other.

To fully understand the electrostatic concept, some background information will be helpful. Remember when you learned, in a science or physics class, that like charges repel each other and opposite charges attract each other? Well, this principle is the foundation of the electrostatic concept.

An electrostatic transducer consists of three pieces: the stators, the diaphragm and the spacers. See *Figure 1*. The diaphragm is what actually moves to excite the air and create music. The stator's job is to remain stationary, hence the word stator, to provide a reference point for the moving diaphragm. The spacers provide the diaphragm with a fixed distance in which to move between the stators.

As your amplifier sends music signals to an electrostatic speaker, these signals are changed into two high-voltage signals that are equal in strength but opposite in polarity. These high voltage signals are then applied to the stators. The resulting electrostatic field, created by the opposing high voltage on the stators, works simultaneously with and against the diaphragm, consequently moving it back and forth, producing music. This technique

is known as push-pull operation and is a major contributor to the sonic purity of the electrostatic concept due to its exceptional linearity and low distortion.

Since the diaphragm of an electrostatic speaker is uniformly driven over its entire area, it can be extremely light and flexible. This allows it to be very responsive to transients, thus perfectly tracing the music signal. As a result, great delicacy, nuance and clarity is possible. When you look at the problems of traditional electromagnetic drivers, you can easily see why this is so beneficial. The cones and domes which are used in traditional electromagnetic drivers cannot be driven uniformly

because of their design. Cones are driven only at the apex. Domes are driven at their perimeter. As a result, the rest of the cone or dome is just "along for the ride". The very concept of these drivers require that the cone or dome be perfectly rigid, damped and massless. Unfortunately these conditions are not available in our world today.

To make these cones and domes move, all electromagnetic drivers must use voice coils wound on formers, spider assemblies, and surrounds to keep the cone or dome in position. See *Figure 2*. These pieces, when combined with the high mass of the cone or dome materials used, make it an extremely complex unit with many weaknesses and potential for failure. These faults contribute to the high distortion products found in these drivers and is a tremendous disadvantage when you are trying to change motion as quickly and as accurately as a loudspeaker must (40,000 times per second!).

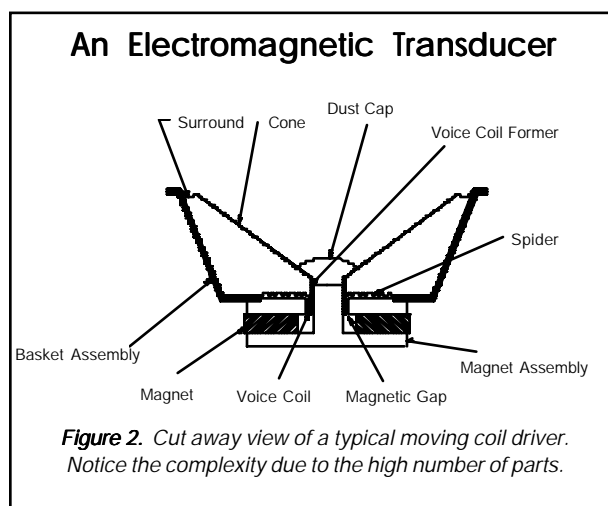
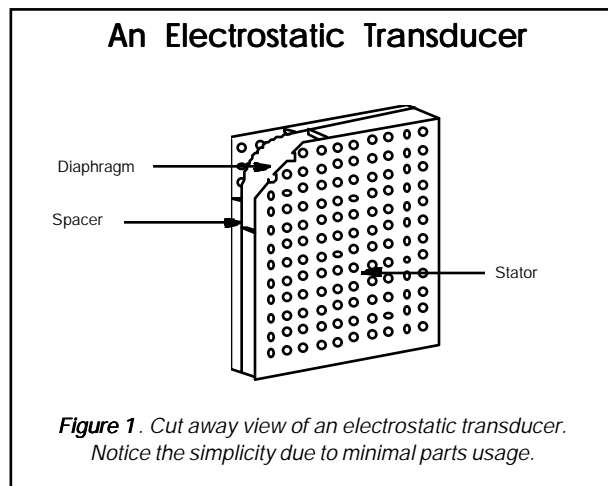

# History

---

In the late 1800's, any loudspeaker was considered exotic. Today, most of us take the wonders of sound reproduction for granted.

It was 1880 before Thomas Edison had invented the first phonograph. This was a horn-loaded diaphragm that was excited by a playback stylus. In 1898, Sir Oliver Lodge invented a cone loudspeaker, which he referred to as a "bellowing telephone", that was very similar to the conventional cone loudspeaker drivers that we know today. However, Lodge had no intention for his device to reproduce music, because in 1898 there was no way to amplify an electrical signal! As a result, his speaker had nothing to offer over the acoustical gramophones of the period. It was not until 1906 that Dr. Lee DeForrest invented the triode vacuum tube. Before this, an electrical signal could not be amplified. The loudspeaker, as we know it today, should have ensued then, but it did not. Amazingly, it was almost twenty years before this would occur.

In 1921, the electrically cut phonograph record became a reality. This method of recording was far superior to the mechanically cut record and possessed almost 30 dB of dynamic range. The acoustical gramophone couldn't begin to reproduce all of the information on this new disc. As a result, further developments in loudspeakers were needed to cope with this amazing new recording medium.

By 1923, Bell Telephone Laboratories made the decision to develop a complete musical playback system consisting of an electronic phonograph and loudspeaker to take advantage of the new recording medium. Bell Labs assigned the project to two young engineers, C.W. Rice and E.W. Kellogg.

Rice and Kellogg had a well equipped laboratory at their disposal. This lab possessed a vacuum tube amplifier with an unheard of 200 watts, a large selection of the new electrically cut phonograph records and a variety of loudspeaker prototypes that Bell Labs had been collecting over the past decade. Among these were Lodge's cone, a speaker that used compressed air, a corona discharge (plasma) speaker, and an electrostatic speaker.

After a short time, Rice and Kellogg had narrowed the

field of "contestants" down to the cone and the electrostat. The outcome would dictate the way that future generations would refer to loudspeakers as being either "conventional", or "exotic".

Bell Laboratory's electrostat was something to behold. This enormous bipolar speaker was as big as a door. The diaphragm, which was beginning to rot, was made of the membrane of a pig's intestine that was covered with fine gold leaf to conduct the audio signal.

When Rice and Kellogg began playing the new electrically cut records through the electrostat, they were shocked and impressed. The electrostat performed splendidly. They had never heard instrumental timbres reproduced with such realism. This system sounded like real music rather than the honking, squawking rendition of the acoustic gramophone. Immediately, they knew they were on to something big. The acoustic gramophone was destined to become obsolete.

Due to Rice and Kellogg's enthusiasm, they devoted a considerable amount of time researching the electrostatic design. However, they soon encountered the same difficulties that even present designers face; planar speakers require a very large surface area to reproduce the lower frequencies of the audio spectrum. Because the management at Bell Labs considered large speakers unacceptable, Rice and Kellogg's work on electrostatics would never be put to use for a commercial product. Reluctantly, they advised the Bell management to go with the cone. For the next thirty years the electrostatic design lay dormant.

During the Great Depression of the 1930's, consumer audio almost died. The new electrically amplified loudspeaker never gained acceptance, as most people continued to use their old Victrola-style acoustic gramophones. Prior to the end of World War II, consumer audio saw little, if any, progress. However, during the late 1940's, audio experienced a great rebirth. Suddenly there was tremendous interest in audio products and with that, a great demand for improved audio components. No sooner had the cone become established than it was challenged by products developed during this new rebirth.

In 1947, Arthur Janszen, a young Naval engineer, took

---

part in a research project for the Navy. The Navy was interested in developing a better instrument for testing microphone arrays. The test instrument needed an extremely accurate speaker, but Janszen found that the cone speakers of the period were too nonlinear in phase and amplitude response to meet his criteria. Janszen believed that electrostats were inherently more linear than cones, so he built a model using a thin plastic diaphragm treated with a conductive coating. This model confirmed Janszen's beliefs, for it exhibited remarkable phase and amplitude linearity.

Janszen was so excited with the results that he continued research on the electrostatic speaker on his own time. He soon thought of insulating the stators to prevent the destructive effects of arcing. By 1952 he had an electrostatic tweeter element ready for commercial production. This new tweeter soon created a sensation among American audio hobbyists. Since Janszen's tweeter element was limited to high frequency reproduction, it often found itself used in conjunction with woofers, most notably, woofers from Acoustic Research. These systems were highly regarded by all audio enthusiasts.

As good as these systems were, they would soon be surpassed by another electrostatic speaker.

In 1955, Peter Walker published three articles on electrostatic loudspeaker design in *Wireless World*, a British electronics magazine. In these articles Walker demonstrated the benefits of the electrostatic loudspeaker. He explained that electrostatics permit the use of diaphragms that are low in mass, large in area, and uniformly driven over their surfaces by electrostatic forces. Due to these characteristics, electrostats have the inherent ability to produce a wide bandwidth, flat frequency response with distortion products being no greater than the electronics driving them.

By 1956 Walker backed up his articles by introducing a consumer product, the now famous Quad ESL. This speaker immediately set a standard of performance for the audio industry due to its incredible accuracy. However, in actual use the Quad had a few problems. It could not play very loud, it had poor bass performance, it presented a difficult load that some amplifiers did not like,

its dispersion was very directional, and its power handling was limited to around 70 watts. As a result, many people continued to use box speakers with cones. In the early 1960's Arthur Janszen joined forces with the KLH loudspeaker company and together they introduced the KLH 9. Due to the large size of the KLH 9, it did not have as many limitations as the Quad. The KLH 9 could play markedly louder and lower in frequency than the Quad ESL. Thus a rivalry was born.

Janszen continued to develop electrostatic designs. He was instrumental in the design of the Koss Model One, the Acoustech, and the Dennesen speakers. Roger West, the chief designer of the JansZen Corporation became the president of Sound Lab. When JansZen Corporation was sold, the RTR loudspeaker company bought half of the production tooling. This tooling was used to make the electrostatic panels for the Servostatic, a hybrid electrostatic system that was Infinity's first speaker product. Other companies soon followed; each with their own unique applications of the technology. These include Acoustat, Audiostatic, Beverage, Dayton Wright, Sound Lab, and Stax to name a few.

Electrostatic speakers have progressed and prospered because they actually do what Peter Walker claimed they would. The limitations and problems experienced in the past were not inherent to the electrostatic concept. They were related to the applications of these concepts.

Today, these limitations have been addressed. Advancements in materials due to the U.S. space program give designers the ability to harness the superiority of the electrostatic principle. Today's electrostats use advanced insulation techniques or provide protection circuitry. The poor dispersion properties of early models have been addressed by using delay lines, acoustical lenses, multiple panel arrays or, as in our own products, by curving the diaphragm. Power handling and sensitivity have been increased.

These developments allow the consumer the opportunity to own the highest performance loudspeaker products ever built. It's too bad Rice and Kellogg were never able to see just how far the technology would be taken.

# Martin-Logan Exclusives

---

## Full Range Operation

The most significant advantage of Martin-Logan's exclusive transducer technology reveals itself when you compare to examples of other loudspeaker products on the market today.

The Aerius uses no crossover networks above 500 Hz because they are not needed. It consists of a single, seamless electrostatic membrane reproducing all frequencies above 500 Hz simultaneously. How is this possible?

First, it is important to understand that music is not composed of separate high, mid and low frequency pieces. In fact, music is comprised of a single complex waveform with all frequencies interacting simultaneously.

The electrostatic transducer of the Aerius essentially acts as an exact opposite of the microphones used to record the original event. A microphone, which is a single working element, transforms acoustic energy into an electrical signal that can be amplified or preserved by some type of storage media. The Aerius electrostatic transducer transforms electrical energy from your amplifier into acoustical energy with a single membrane.

Upon looking carefully at a traditional magnetic driver (i.e. dynamic, ribbon, induction), no single unit can reproduce the full range of frequencies.

Instead, these drivers must be designed to operate within narrow areas of music and then combined electrically so that the sum of the parts equals the total signal. While this sounds nice in theory, a different story unfolds in real-world conditions.

In order to use multiple drivers, a crossover network is enlisted to divide the complex musical signal into the separate parts (usually highs, mids, and lows) that each specific driver was designed to handle. Unfortunately, due to the phase relationships that occur within all crossover networks and during the acoustical recombination

process, nonlinearities and severe degradation of the music signal takes place in the ear's most "critical zone". See Figure 1.

So, music in the "critical zone" becomes delayed in time. These delays can be picked-up by your ear and result in poor imaging and ambience cues.

**The Aerius electrostatic transducer can single-handedly reproduce all frequencies above 500 Hz simultaneously.**

The crossover phase discontinuities that are associated with traditional tweeter, midrange, and woofer systems are eliminated in the Aerius. This results in a **dramatic improvement in imaging and staging performance due to the minutely accurate phase relationship of the full-range panel wave launch.**

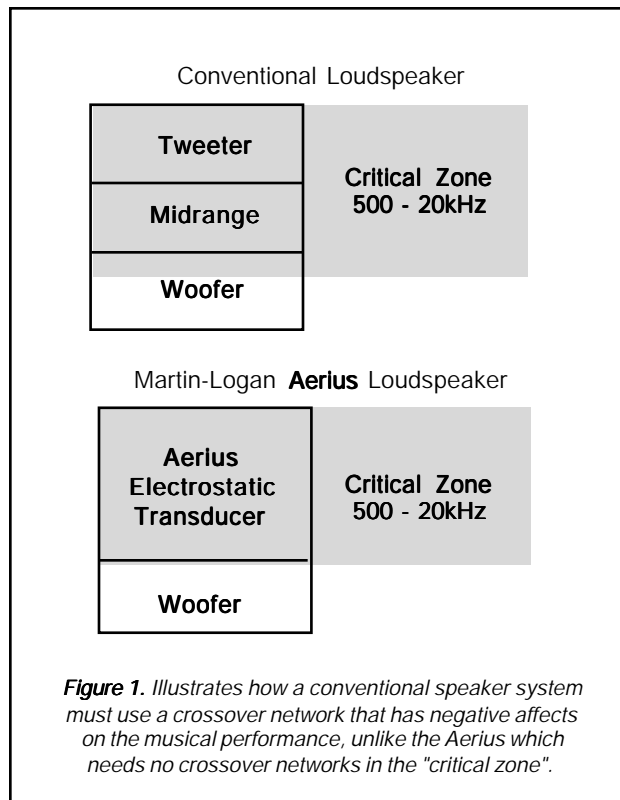



---

## Vapor Deposited Film

The diaphragm material used in all Martin-Logan speakers employs an extremely sophisticated vapor deposited conductive polymer surface. A proprietary conductive compound is vaporized then electrostatically driven into the surface of the polymer film in a vacuum chamber. This process allows an optically transparent membrane, adds no mass to the diaphragm and is extremely uniform in its surface resistivity characteristics. This uniform surface resistivity controls the electrostatic charge on the diaphragm surface and regulates its migration. As a result, no discharging or " arcing " can occur.

## Transducer Integrity

All Martin-Logan transducers begin with two pieces of high grade, cold rolled steel. These steel pieces are then custom perforated and insulated with an exotic composite coating. This proprietary coating insulates the stator to 3 times its actual needed working voltage and gives the Aeries a wide margin of safe operation. In addition to the electrical insulation properties, this coating also provides the Aeries with a durable, attractive finish that dampens the steel to prevent ringing. The finished metal plates are curved into a 30 degree arc. Placed between them is our exclusive vapor deposited diaphragm and spacers. This assembly is then bonded together with aerospace adhesives whose strength exceeds that of welding.

The result of these advanced technologies is a transducer that is attractive, durable, highly rigid, well dampened, and neutral.

## Mechanical/Acoustical Tone Shaping

The clear Lexan® panels on the back of the Aeries stator are the key elements of an innovative pressure compensation technology. Martin-Logan is able to tone-shape the

diaphragm + or - 6dB without the use of an insertion loss crossover. The advantage of this system is a high efficiency driver with wide bandwidth capabilities of dimensions which are easily integrated into a domestic environment.

## Curvilinear Line Source

Since the beginning of Audio, achieving smooth full range dispersion has long been a problem for all loudspeaker designers. Large panel transducers present even more of a challenge because the larger the panel, the more directional the dispersion pattern becomes.

Full range electrostats have always been one of the most complex transducers because they attain their full range capabilities via a large surface area. It looked as if they were in direct conflict to smooth dispersion and almost every attempt to correct this resulted in either poor dispersion or a serious compromise in sound quality.

After extensive research, Martin-Logan engineers discovered an elegantly simple solution to achieve a smooth pattern of dispersion without degrading sound quality. By curving the horizontal plane of the electrostatic transducer, a controlled horizontal dispersion pattern could be achieved, yet the purity of the almost massless electrostatic diaphragm remained uncompromised. After creating this technology, we developed the production capability to bring this technology out of the laboratory and into the market place.

You will find this proprietary Martin-Logan technology used in all of our products. It is one of the many reasons behind our reputation for high quality sound with practical usability. This is also why you see the unique "see through" cylindrical shape of all Martin-Logan products.

# Operation

---

## AC Power Connection

Because your Martin-Logan Aeries use an internal power supply to energize their electrostatic cells with high-voltage DC, they must be connected to an AC power source. For this reason they are provided with the proper IEC standard power cords. These cords should be firmly inserted into any convenient AC wall outlet. Extension cords may be used, if necessary, since the AC power requirement of the speaker is extremely small (less than 5 watts). The Aeries have been designed to remain on continuously and should remain connected to a continuous AC power source. As mentioned earlier, power consumption of the Aeries is very small and the life expectancy of its components will not be reduced by continuous operation.

***The power cord should not be installed, removed, or left detached from the speaker while the other end is connected to an AC power source.***

Your Aeries speakers are wired for the power service supplied in the country of original consumer sale unless manufactured on special order. The AC power rating applicable to a particular unit is specified both on the packing carton and on the serial number plate attached to the speaker.

If you remove your Aeries speakers from the country of original sale, be certain that AC power supplied in any subsequent location is suitable before connecting and operating the speakers. Substantially impaired performance or severe damage may occur to a Aeries speaker if operation is attempted from an incorrect AC power source.

If your home is not equipped with three-prong wall outlets, you may use "cheater" plugs to connect the speakers to AC power. These may be obtained at your dealer or any hardware department.

## Signal Connection

Use the best speaker cables you can! The length and type of speaker cable used in your system will have an audible effect. Under no circumstance should a wire of gauge higher (thinner) than #16 be used. In general, the longer the length used, the greater the necessity of a lower gauge, and the lower the gauge, the better the sound, with diminishing returns setting in around #8 to #12.

A variety of speaker cables are now available whose manufacturers claim better performance than with standard heavy gauge wire. We have verified this in some cases, and the improvements available are often more noticeable than the differences between wires of different gauge.

We would also recommend, if possible, that short runs of speaker cable connect the power amplifier(s) and speakers and that high quality long interconnect cables be used to connect the preamplifier and power amplifier. This results in the power amplifiers being close to the speakers, which may be practically or cosmetically difficult, but if the length of the speaker cables can be reduced to a few meters, sonic advantages may be obtained. The effects of cables may be masked if the equipment is not of the highest quality.

Connections are done at the **Signal Input** section on the rear electronics panel of the Aeries. Use spade connectors for optimum contact and ease of installation. Make certain that all your connections are tight.

Be consistent when connecting the speaker cables to the **Signal Input** terminals. Take care to assign the same color cable lead to the (+) terminal on both the left and right channel speakers. If bass is nonexistent and you cannot discern a tight, coherent image, you may need to reverse the (+) and (-) leads on one speaker to bring the system into proper polarity.

**CAUTION!**

Turn your amplifier off before making or breaking any signal connections!

## Standard Connection

Connect the speaker wire from your amplifier to the **Signal Input** binding post. See figure 1.

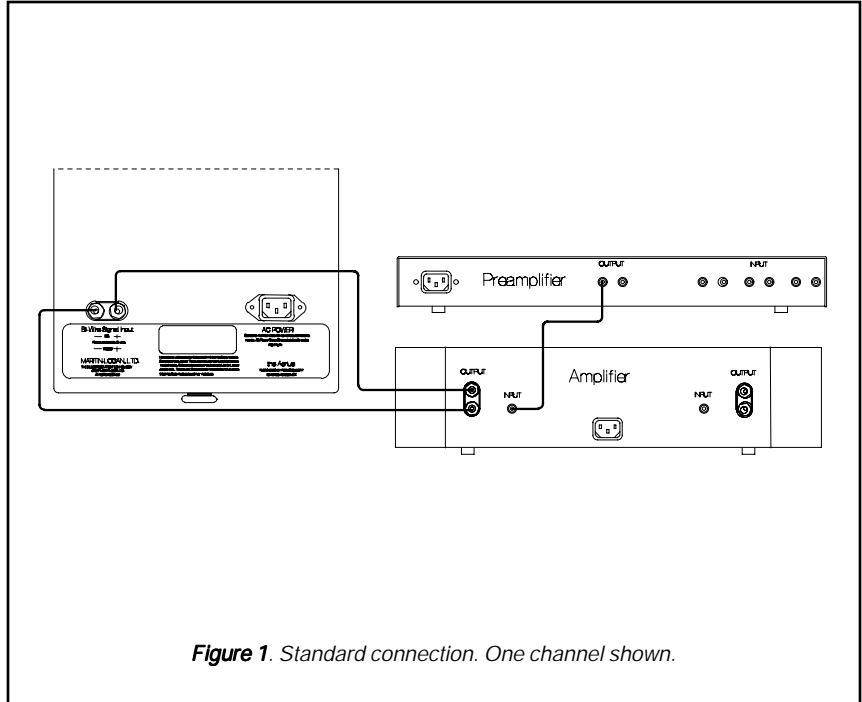

## Optional Bi-Wire Connection

This method of connection replaces the jumper clips installed under the 5-way binding posts with individual runs of speaker wire from your amplifier. This doubles the signal carrying conductors from the audio amplifier to the speaker, thus direct-coupling each portion of the crossover to the amplifier.

To bi-wire you must **first loosen the 5-way binding posts and remove the jumper clips**. Connect one set of wires to the **ESL +** and - binding posts of the Aeries. Then connect a second set of wires to the **Woofers +** and - binding posts. Next, connect both sets of wires to the appropriate terminals on your amplifier. Please take care to connect both (+) wires to the (+) amplifier terminals and both (-) wires to the (-) amplifier terminals. This is known as a parallel connection. See Fig 2.

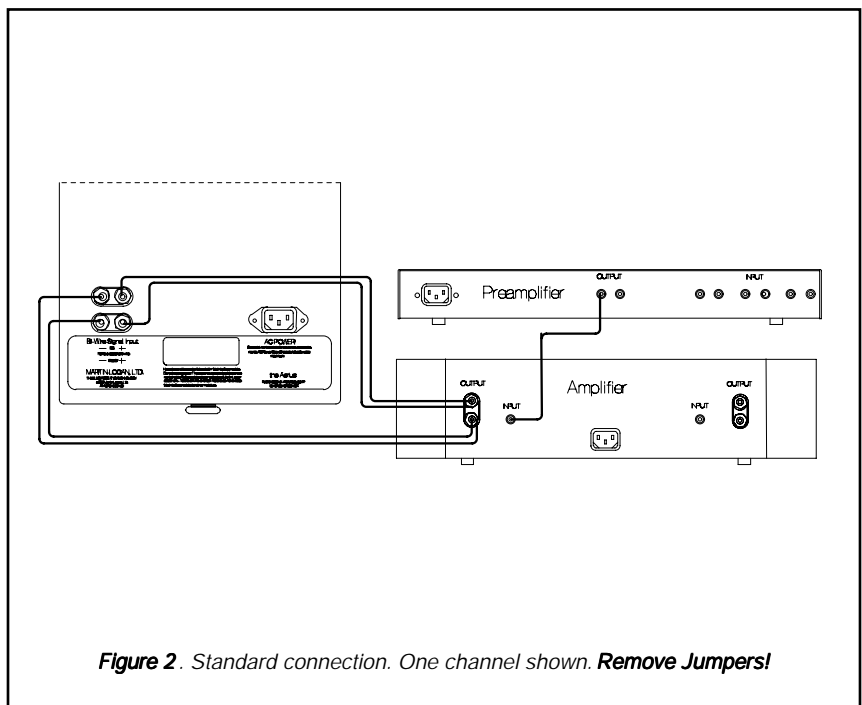

# Room Acoustics

---

## Your Room

This is one of those areas that requires both a little background to understand and some time and experimentation to obtain the best performance from your system.

Your room is actually a component and an important part of your system. This component is a very large variable and can dramatically add to, or subtract from, a great musical experience.

All sound is composed of waves. Each note has its own wave size, with the lower bass notes literally encompassing from 10' to as much as 40'! Your room participates in

this wave experience like a 3 dimensional pool with waves reflecting and becoming enhanced depending on the size of the room and the types of surfaces in the room.

Remember, your audio system can literally generate all of the information required to recreate a musical event in time, space, and tonal balance. The purpose of your room, ideally, is to not contribute to that information. However, every room does contribute to the sound and the better speaker manufacturers have designed their systems to accommodate this phenomenon.

Let's talk about a few important terms before we begin.

---

## Terminology

**Standing Waves.** The parallel walls in your room will reinforce certain notes to the point that they will sound louder than the rest of the audio spectrum and cause "one note bass", "boomy bass", or "tubby bass". For instance, 100Hz represents a 10' wavelength. Your room will reinforce that specific frequency if one of the dominant dimensions is 10'. Large objects in the room such as cabinetry or furniture can help to minimize this potential problem. Some serious "audiophiles" will literally build a special room with no parallel walls just to get away from this phenomenon.

**Reflective Surfaces (near-field reflections).** The hard surfaces of your room, particularly if close to your speaker system, will reflect those waves back into the room over and over again, confusing the clarity and imaging of your system. The smaller sound waves are mostly effected here and occur in the mid and high frequencies. This is where voice and frequencies as high as the cymbals can occur.

**Resonant Surfaces and Objects.** All of the surfaces and objects in your room are subject to the frequencies generated by your system. Much like an instrument, they will vibrate and "carry on" in syncopation with the music and contribute in a negative way to the music. Ringing, boominess, and even brightness can occur simply because they are "singing along" with your music.

**Resonant Cavities.** Small alcoves or closet type areas in your room can be chambers that create their own "standing waves" and can drum their own "one note" sounds.

Clap your hands. Can you hear an instant echo respond back? You've got near-field reflections. Stomp your foot on the floor. Can you hear a "boom"? You've got standing waves or large panel resonances such as a poorly supported wall. Put your head in a small cavity area and talk loudly. Can you hear a booming? You've just experienced a cavity resonance.

---

## Rules of Thumb

**Hard vs. Soft Surfaces.** If the front or back wall of your listening room is soft, it may benefit you to have a hard or reflective wall in opposition. As well, the ceiling and floor should follow the same basic guideline. However, the side walls should be roughly the same in order to deliver a focused image.

This rule suggests that a little reflection is good. As a matter of fact, some rooms can be so “over damped” with carpeting, drapes and sound absorbers that the music system can sound dull and lifeless. On the other hand, rooms can be so hard that the system can sound like a gymnasium with too much reflection and brightness. The point is that balance is the optimum environment.

**Break-up Objects.** Objects with complex shapes, such as bookshelves, cabinetry, and multiple shaped walls can help break up those sonic gremlins and diffuse any dominant frequencies.

**Solid Coupling.** Your loudspeaker system generates frequency vibrations or waves into the room. This is how it creates sound. Those vibrations will vary from 20 per second to 20,000 per second. If your speaker system is not securely planted on the floor or solid surface, it can shake as it produces sound and, consequently, the sound can be compromised. If your speaker is sitting on the carpet and only foot gliders are used, the bass can be ill defined and even boomy. The use of spikes is recommended to insure secured footing for your speakers.

---

## Dipolar Speakers and Your Room

Martin-Logan electrostatic loudspeakers are known as dipolar radiators. This means that they produce sound from both their fronts and their backs. Consequently, musical information is reflected by the wall behind them and may arrive either in or out of step with the information produced by the front of the speaker.

The low frequencies can either be enhanced or nulled by the position from the front wall. Your Aeries have been designed for the front of the speaker to be placed 2 to 3 feet from the front wall (the wall in front of the listening position) to obtain the best results, however your room may see things differently. So, listening to the difference of the bass response as a result of the changes in distance from the front wall can allow you to get the best combination of depth of bass and tonal balance.

Now that you know about **Reflective Surfaces** and **Resonant Objects**, you can see how the mid-range and high frequencies can be effected. The timing of the first wave as it is first radiated to your ears and then the reflected information as it arrives at your ears later in time, can result in confusion of the precious timing information that carries the clues to imaging and, consequently result in blurred imaging and excessive brightness. Soft walls, curtains, wall hangings, or sound dampeners (your dealer can give you good information here) can be effective if these negative conditions occur.

# Room Acoustics and Dispersion Interactions

## Controlled Horizontal Dispersion

Your Aeries launch a 30 degree dispersion pattern when viewed from above. This horizontal dispersion field gives you a choice of good seats for the performance while minimizing interaction with side walls. See *Figure 1*.

Make sure both speakers stand exactly at the same vertical angle, otherwise the image can be skewed or poorly defined. The wave launch of both speakers is extremely accurate in both the time and spectral domain and, consequently, small refined adjustments can result in noticeable sonic improvements.

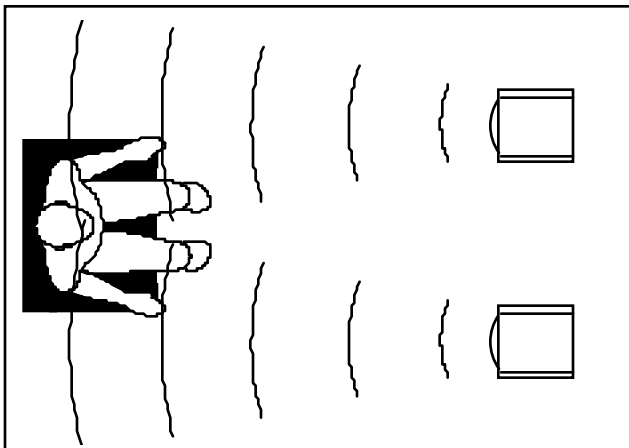

**Figure 1.** Martin-Logan Aeries deliver a 30 degree wave launch dispersion pattern distributed horizontally.

## Controlled Vertical Dispersion

As you can see from the illustrations, your Aeries project a controlled dispersion pattern. Each Aeries is a 3.75 foot line source beginning one foot above floor level. See *Figure 2*. This vertical dispersion profile minimizes interactions with the floor and the ceiling.

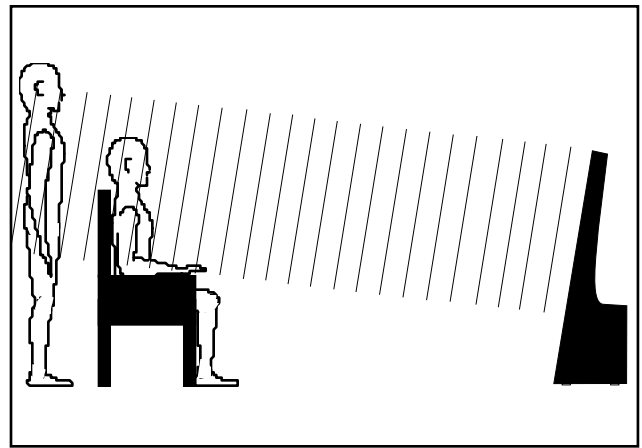
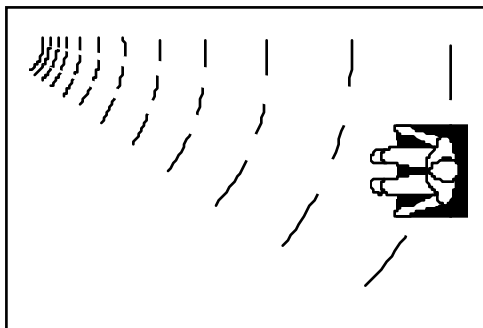

**Figure 2.** Your Aeries speaker system is a 3.75 foot line source when viewed vertically. Actual height above the floor is from one to 4.75 feet.

## Three Major Types of Dispersion

In the field of loudspeaker design, it is a known fact that as the sound wave becomes progressively smaller than the transducer producing it, the dispersion of that wave becomes more and more narrow, or directional. This fact occurs as long as the transducer is a flat surface. Large flat panel speakers exhibit **venetian blind** effects due to this phenomenon. This is why most manufacturers opt for small drivers (i.e. tweeters and midrange) to approximate what is known as a **point source** wave launch.

Historically, most attempts to achieve smooth dispersion from large flat panel transducers resulted in trade-offs. After exhaustive testing of these different solution attempts, we found an elegantly simple, yet very difficult to execute solution. By curving the radiating surface, we create the effect of a horizontal arc. This allows the engineers at Martin-Logan to control the high frequency dispersion pattern of our transducers. That is why you see the gentle curve on our products.



### **Multiple Large Panel Dispersion**

*Even though they suffer from "venetian blind" effect, angled multiple panel speakers can deliver good imaging, but only to specific spots in the listening area.*

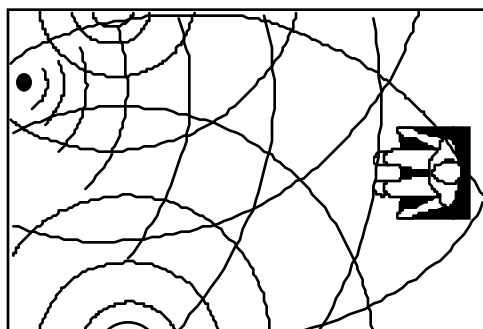
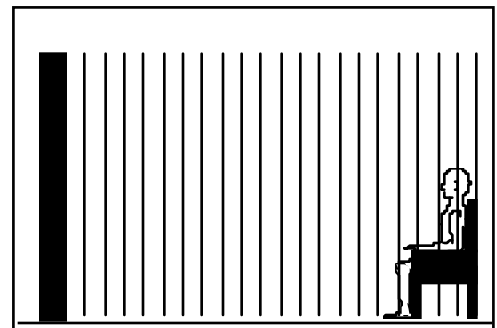

### **Traditional Point Source Dispersion**

*As can be seen, **point source** concepts invite a great deal of room interaction. While delivering good frequency response to a large listening audience, imaging is consequently confused and blurred.*

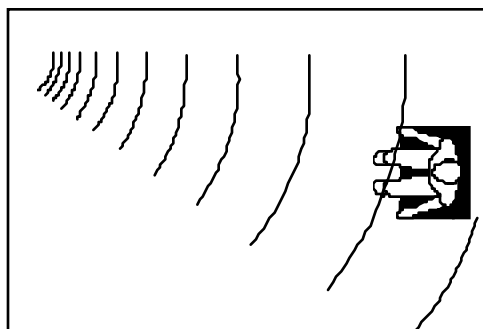
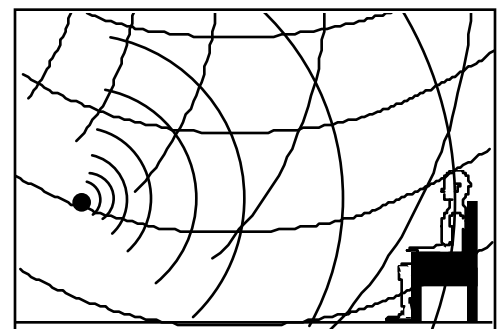

### **Curvilinear Line Source Dispersion**

*A controlled 30-degree cylindrical wavefront, which is a **Martin-Logan exclusive**, offers optimal sound distribution with minimal room interaction. The result is solid imaging with a wide listening area.*

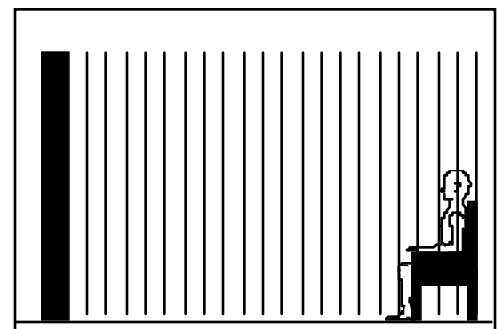

# Placement

---

## Listening Position

By now the front of your speakers should be placed approximately 2 to 3 feet from the front wall (wall in front of the listening position) and at least 1 to 2 feet from the side walls. Your sitting distance should be further than the distance between the speakers themselves. What you are trying to attain is the impression of good center imaging and stage width.

There is no exact distance between speakers and listener, but there is a relationship. In long rooms, naturally, that relationship changes. The distance between the speakers will be far less than the distance from you to the speaker system. However, in a wide room you will still find that if the distance from the listener to the speakers becomes smaller than the distance between the speakers themselves, the image will no longer focus in the center.

Now that you have positioned your speaker system, spend some time listening. Wait to make any major changes in your initial set-up for the next few days as the speaker system itself will change subtly in its sound. Over the first 20 hours of play the actual tonal quality will change slightly with deeper bass and more spacious highs resulting.

After a few days of listening you can begin to make refinements and hear the differences of those refinements.

## The Wall Behind the Listener

Near-field reflections can also occur from your back wall (the wall behind the listening position). If your listening position is close to the back wall, these reflections can cause problems and confuse the quality of imaging. Actually it is better for the wall behind you to be soft than to be bright. If you have a hard back wall and your listening position is close to it, experiment with devices that will soften and absorb information (i.e. wall hangings and possibly even sound absorbing panels).

## The Wall Behind the Speakers

The front wall should not be extremely hard or soft. For instance, a pane of glass will cause reflections, brightness, and confused imaging. Curtains, drapery and objects such as bookshelving can be placed along the wall to tame an extremely hard surface. A standard sheet rock or textured wall is generally an adequate surface if the rest of the room is not too bright and hard.

Sometimes walls can be too soft. If the entire front wall consists of only heavy drapery, your system can literally sound too soft or dull. You may hear dull, muted music with little ambience. Harder room surfaces will actually help in this case.

The front surface should, optimally, be one long wall without any doors or openings. If you have openings, the reflection and bass characteristics from one channel to the other can be different.

## The Side Walls

The same requirements exist for side walls. Additionally, a good rule of thumb is to have the side walls as far away from the speaker sides as possible, minimizing near field side wall reflections. Sometimes, if the system is bright or the imaging is not to your liking, and the side walls are very near, try putting curtains or softening material directly to the edge and forward of each speaker. An ideal side wall, however, is no side wall at all.

## Experimentation

**Toe-in** Now you can begin to experiment. First begin by toeing your speakers in towards the listening area and then toeing them straight into the room. You will notice that the tonal balance changes ever so slightly. You will also notice the imaging changing. Generally it is found that the ideal listening position is with the speakers **slightly toed-in** so that you are listening to the inner third of the curved transducer section.



---

Experimenting with the toe-in will help in terms of tonal balance. You will notice that as the speakers are toed-out, the system becomes slightly brighter than when toed-in. This design gives you the flexibility to modify a soft or bright room.

#### **Tilting the Speakers Backwards and Forwards.**

As can be seen from the diagrams in the **Room Acoustics** section of this manual, the vertical dispersion is directional above and below the stator panel itself. In some instances, if you are sitting close to the floor, slight forward tilting of the speakers can enhance clarity and precision.

**Imaging.** In their final location, your Aeries should have a stage width somewhat wider than the speakers themselves. On well recorded music, the instruments should extend beyond the edges of each speaker to the left and to the right, yet a vocalist should appear directly in the middle. The size of the instruments should be neither too large nor too small. Additionally, you should find good clues as to stage depth. Make sure, when listening, that the vertical alignment, distance from the front wall, and toe in is exactly the same from one speaker to the other. This will greatly enhance the quality of your imaging.

**Bass Response.** Your bass response should neither be one note nor should it be too heavy. It should extend fairly deep to even the deepest organ passages, yet it should be tight and well defined. Kick-drums should be tight and percussive, string bass notes should be uniform and consistent throughout the entirety of the run without any booming or thudding.

**Tonal Balance.** Voices should be natural and full, cymbals should be detailed and articulate yet not bright and piercing, pianos should have a nice transient characteristic and deep tonal registers as well. If you cannot attain these virtues, re-read the section on **Room Acoustics**. This will give you clues on how to get closer to those ideal virtues.

## A Final Word

**Final Placement.** After obtaining good wall treatments and attaining proper angle, begin to experiment with the distance from the wall behind the speakers. Move your speaker slightly forward into the room. What happened to the bass response? What happened to the imaging? If the imaging is more open and spacious and the bass response tightened, that is a superior position. Move the speakers back six inches from the initial set-up position. Again, listen to the imaging and bass response. There will be a position where you will have pin-point imaging and good bass response. That position becomes the point of the optimal placement from the front wall.

Now experiment with placing the speakers farther apart. As the speakers are positioned farther apart, listen again, not so much for bass response but for stage width and good pin-point focusing.

Your ideal listening position and speaker position will be determined by: **1) tightness and extension of bass response, 2) the width of the stage, and 3) the pin-point focusing of imaging.** Once you have found the best of all three of those considerations, you will have your best speaker location.

After living and experimenting with your Aeries, you will then want to use the spikes included in your owners kit. The Aeries will become more firmly planted on the floor and, consequently, bass will tighten and imaging will become more coherent and detailed. It is best not to implement the spikes, however, until you are secure in the positioning as the spikes can damage the floors if the speaker is moved.

The Aeries is a very refined speaker and, as such, benefits from care in set-up. With these tips in mind, you will find, over your months of listening, that small changes can result in demonstrable differences. As you live with your speakers, do not be afraid to experiment with their positioning until you find the optimal relationship between your room and your speaker system to give you the best results. Your efforts will be rewarded.

You are now armed with the fundamentals of room acoustics and the specific fundamentals of the Aeries loudspeaker. **Happy listening!**

# Questions

---

## ***What size of an amplifier should I use with the Aerius?***

We recommend an amplifier with 80 to 200 watts per channel for most applications. The Aerius will perform well with either a tube or transistorized amplifier, and will reveal the sonic character of either type. However, it is important that the amplifier be stable operating into varying impedance loads: a stable amplifier will be able to deliver twice its rated wattage into 4 Ohms and should maintain or increase power into 2 Ohms.

## ***Should I unplug my Aerius during a thunderstorm?***

Yes. Or before. It's a good idea to disconnect all of your audio/video components during stormy weather.

## ***Is there likely to be any interaction between the Aerius and the television in my Audio/Video system?***

Actually, there is less interaction between a television and an electrostatic speaker than between a television and a conventional system. The magnets in conventional speakers do interact with television tubes. However, we do recommend that you keep your speakers at least one foot away from the television because of the dynamic woofer they employ.

## ***Could my children, pets, or myself be shocked by the high-voltage present in the electrostatic panel?***

No. High voltage with low current is not dangerous. As a matter of fact, the voltage in our speakers is **10 times less** than the static electricity that builds up on the surface of your television screen.

## ***If my child punctured the diaphragm with a pencil, stick, or similar item., how extensive would the damage to the speaker be?***

Our research department has literally punctured hundreds of holes in a diaphragm, neither affecting the quality of the sound nor causing the diaphragm to rip. However, you will be able to see the actual puncture and it can be a physical nuisance. If this is the case, replacing the electrostatic transducer will be the only solution.

## ***Will my electric bill go 'sky high' by leaving my speakers plugged in all the time?***

No. A **pair** of Aerius draw about 10 watts maximum, about the same as a pair of electric clocks.

## ***Will exposure to sunlight affect the life or performance of the Aerius?***

We recommend that you not place any loudspeaker in direct sunlight as the ultraviolet (UV) rays from the sun can cause deterioration of grill cloth, speaker cones, etc.. Exposures through glass will not cause a problem, however the heat generated by the sun will age the finish on the speaker as it would any fine furniture. Martin-Logan speakers are not recommended for outdoor use.

## ***Will excessive smoke or dust cause any problems?***

Exposure to excessive contaminants, such as smoke or dust, may potentially effect the performance of the electrostatic membrane and may cause discoloration of the diaphragm membrane. When not in use for extended periods, you should unplug the speaker and cover with the plastic bags that the speakers were originally packed.

# Troubleshooting

---

## No Output

- Check that all your system components are turned on.
- Check your speaker wires and connections.
- Check all interconnecting cables.

## Weak Output, Loss of Highs

- Check the power cord. Is it properly connected to the speaker?

## Exaggerated Highs, Brightness

- Check the toe-in of the speakers. Read **Room Placement** for more information.

## Muddy Bass

- Check placement. Try moving the speakers closer to the front and side walls.
- Check the type of feet being used. Try attaching the coupling spikes.

## Lack of Bass

- Check your speaker wires. Is the polarity correct?

## Poor Imaging

- Check placement. Are both speakers the same distance from the walls? Do they have the same amount of toe-in? Try moving the speakers away from the front and side walls.
- Check the polarity of the speaker wires. Are they connected properly?

## Popping and Ticking Sounds, Funny Noises

- These occasional noises are harmless and will not hurt your audio system or your speakers. All electrostatic speakers are guilty of making odd noises at one time or another.
- These noises may be caused by dirt and dust particles collecting on the speaker, by high humidity or by AC line fluctuations that may occur in your area.

Dirt and dust may be vacuumed off with a brush attachment connected to your vacuum cleaner or you may blow them off with compressed air.

**DO NOT SPRAY ANY KIND OF CLEANING AGENT ON OR IN CLOSE PROXIMITY TO THE ELECTROSTATIC ELEMENT.**

# Recommended Music

---

## Analog Discs

*Astounding Sound Show* ..... Reference Recordings RR-7  
*Chet Atkins in Hollywood* ..... RCA LSP-1993  
Berlioz: *Symphonie Fantastique* ..... Chesky Records CR1  
*Big Band Jazz* ..... Umbrella UMB-DD4  
*The Chicago Symphony Wind* ..... Sheffield Lab 22  
Judy Collins: *Judith* ..... Elektra 6E-111  
Phil Collins: *Face Value* ..... Virgin V-2185  
*Dafos* ..... Reference Recordings RR-12  
Miles Davis: *You're Under Arrest* ..... Columbia FC 40023  
Arturo Delmoni:  
    *Songs My Mother Taught Me* ..... North Star DS0004  
Dire Straits: *Dire Straits* ..... Warner Bros. BSK 3266  
Dire Straits: *Love Over Gold* ..... Warner Bros. 23728-1  
*Fresh Aire II* ..... American Gramophone 359  
*Fresh Aire III* ..... American Gramophone 365  
Gershwin: *An American in Paris* ..... Chesky Records RC8  
Earl Klugh: *Crazy for You* ..... Liberty LT 51113  
Mahler: *Symphony No. 1* ..... Telarc DG10066  
Joni Mitchell: *For the Roses* ..... Asylum SD 5057  
Moroder: *Cat People* ..... Backstreet BSR-6107  
*The Moscow Sessions* ..... Sheffield Lab TLP-1000  
Ohio Players: *Gold* ..... Mercury SRM-1-1122  
Pink Floyd: *Dark Side of the Moon* .. EMI Harvest SHVL-804  
Rachmaninoff: *Piano Concerto No. 2*. Chesky Records CR2  
*The Reiner Sound* ..... RCA LSC-2183  
Rickie Lee Jones: *Rickie Lee Jones* Warner Bros. BSK 3296  
Shalamar: *The Look* ..... Solar 9-60239  
*The Sheffield Track Record* ..... Sheffield Lab-20  
Strauss: *Til Eulenspiegel* ..... Reference Recordings RR-16  
Stanley Turrentine: *Cherry* ..... CTI Records CTI 6017  
McCoy Tyner & Jackie McLean:  
    *It's About Time* ..... Blue Note BT 85102  
Dionne Warwick: *Soulful* ..... Scepter SPS-573

## Compact Discs

Pachelbel Canon:  
    *The Academy of Ancient Music*, L'Oiseau-Lyre 410 553-2  
Count Basie & His Orchestra: *88 Basie Street*, Pablo 3112-42  
David Benoit:  
    *Every Step of the Way* ..... GRP Records GRD-9558  
    *This Side Up* ..... En Pointe ENP 0001  
*Cantate Domino* ..... Proprius PRCD 7762  
Copland:  
    *Appalachian Spring, Rodeo, Fanfare* .. Telarc CD-80078  
*Country* ..... Windham Hill Records WD-1039  
*Dafos* ..... Reference Recordings RR-12 CD  
Dire Straits: *Brothers in Arms* ..... Warner Bros. 9 25264-2  
*Dorian Sampler Vol. 1* ..... Dorian DOR-90001  
Freddie Hubbard: *Ride Like the Wind* .. En Pointe ENP 0002  
Huey Lewis and the News: *Sports* ..... Chrysalis VK 41412  
Bob James & Earl Klugh: *One On One* ..... CBS CK 36241  
Albert King: *Live Wire* ..... Mobile Fidelity MFCD 838  
Rob McConnell and the Boss Brass:  
    *Present Perfect* ..... MPS 823 543-2  
*Nojima Plays Liszt* ..... Reference Recordings RR-25CD  
Linda Ronstadt: *Round Midnight* ..... Asylum 9 60489-2  
*Round-Up* ..... Telarc CD-80141  
Sainte-Saens: *Symphony No. 3* ..... Phillips 412 619-2  
*Diane Schuur and the Count Basie Orchestra*,  
    GRP Records GRD-9550  
Paul Simon: *Graceland* ..... Warner Bros. 9 25447-2  
*Ein Straussfest* ..... Telarc CD-80098  
Tchaikovsky: *Piano Concerto No. 1* Chesky Records CD-13  
Tchaikovsky: *Violin Concerto* ..... Chesky Records CD-12  
Vollenweider: *Caverna Magica* ..... CBS MK 37827  
Steve Winwood: *Back in the High Life* ..... Island 9 25548-2  
Yellowjackets: *Shades* ..... MCA Records MCAD-5752

# Aerius Specifications

---

The Aerius hybrid speaker system consists of a broad-range single element electrostatic transducer integrated with a quick-response woofer. This approach takes advantage of the benefits that both technologies have to offer.

Dispersion is a controlled 30 degrees. This was achieved by curving the electrostatic transducer element itself, an elegantly simple solution.

**Frequency Response**

40 - 20,000 Hz +/- 3dB

**Electrostatic panel dimensions**

38" x 9.5"

**Electrostatic Frequency Response**

300 - 20,000 Hz +/- 2dB

**Woofer size**

8" diameter, 1.25 ft<sup>3</sup> sealed enclosure

**Woofer Frequency Response**

40 - 2,000 Hz +/- 3dB

**Crossover Frequency**

500 Hz, 12dB per Octave

**Dispersion**

Horizontal: 30 degrees; Vertical: 38" Line Source

**Sensitivity**

89 dB 2.83 volts/1 meter

**Power Handling**

200 watts/channel

**Recommend Amplifier Power**

60 - 200 watts/channel

**Impedance**

4 ohms; minimum: greater than 2 ohms at 20,000 Hz

**Weight**

55 lbs. each

**Size**

55.5 H x 10.5 W x 13.5 D

# Glossary

---

**AC.** Abbreviation for alternating current.

**Active crossover.** Uses active devices (transistors, IC's, tubes) and some form of power supply to operate.

**Amplitude.** The extreme range of a signal. Usually measured from the average to the extreme.

**Arc.** The visible sparks generated by an electrical discharge.

**Bass.** The lowest frequencies of sound.

**Bi-Amplification.** Uses an electronic crossover or line-level passive crossover and separate power amplifiers for the high and low frequency loudspeaker drivers.

**Capacitance.** That property of a capacitor which determines how much charge can be stored in it for a given potential difference between its terminals, measured in farads, by the ratio of the charge stored to the potential difference.

**Capacitor.** A device consisting of two or more conducting plates separated from one another by an insulating material and used for storing an electrical charge. Sometimes called a condenser.

**Clipping** Distortion of a signal by its being chopped off. An overload problem caused by pushing an amplifier beyond its capabilities. The flat-topped signal has high levels of harmonic distortion which creates heat in a loudspeaker and is the major cause of loudspeaker component failure.

**Crossover.** An electrical circuit that divides a full bandwidth signal into the desired frequency bands for the loudspeaker components.

**dB (decibel).** A numerical expression of the relative loudness of a sound. The difference in decibels between two sounds is ten times the common logarithm of the ratio of their power levels.

**DC.** Abbreviation for direct current.

**Diffraction** The breaking up of a sound wave caused by some type of mechanical interference such as a cabinet edge, grill frame, or other similar object.

**Diaphragm.** A thin flexible membrane or cone that vibrates in response to electrical signals to produce sound waves.

**Distortion.** Usually referred to in terms of total harmonic distortion (THD) which is the percentage of unwanted harmonics of the drive signal present with the wanted signal. Generally used to mean any unwanted change introduced by the device under question.

**Driver.** See transducer.

**Dynamic Range.** The range between the quietest and the loudest sounds a device can handle (often quoted in dB).

**Efficiency.** The acoustic power delivered for a given electrical input. Often expressed as decibels/watt/meter (dB/w/m).

**ESL.** Abbreviation for electrostatic loudspeaker.

**Headroom.** The difference, in decibels, between the peak and RMS levels in program material.

**Hybrid.** A product created by the marriage of two different technologies. Meant here as the combination of a dynamic woofer with an electrostatic transducer.

**Hz (Hertz).** Unit of frequency equivalent to the number of cycles per second.

**Imaging.** To make a representation or imitation of the original sonic event.

**Impedance.** The total opposition offered by an electric circuit to the flow of an alternating current of a single frequency. It is a combination of resistance and reactance and is measured in ohms. Remember that a speaker's impedance changes with frequency, it is not a constant value.

**Inductance.** The property of an electric circuit by which a varying current in it produces a varying magnetic field that introduces voltages in the same circuit or in a nearby circuit. It is measured in henrys.

**Inductor.** A device designed primarily to introduce inductance into an electric circuit. Sometimes called a choke or coil.

**Linearity.** The extent to which any signal handling process is accomplished without amplitude distortion.

---

**Midrange.** The middle frequencies where the ear is the most sensitive.

**Passive crossover.** Uses no active components (transistors, IC's, tubes) and needs no power supply (AC, DC, battery) to operate. The crossover in a typical loudspeaker is of the passive variety. Passive crossovers consist of capacitors, inductors and resistors.

**Phase.** The amount by which one sine wave leads or lags a second wave of the same frequency. The difference is described by the term phase angle. Sine waves in phase reinforce each other; those out of phase cancel.

**Pink noise.** A random noise used in measurements, as it has the same amount of energy in each octave.

**Polarity.** The condition of being positive or negative with respect to some reference point or object.

**RMS.** Abbreviation for root mean square. The effective value of a given waveform is its RMS value. Acoustic power is proportional to the square of the RMS sound pressure.

**Resistance.** That property of a conductor by which it opposes the flow of electric current, resulting in the generation of heat in the conducting material, usually expressed in ohms.

**Resistor.** A device used in a circuit primarily to provide resistance.

**Resonance.** The effect produced when the natural vibration frequency of a body is greatly amplified by reinforcing vibrations at the same or nearly the same frequency from another body.

**Sensitivity.** Volume of sound delivered for a given electrical input.

**Stator.** The fixed part forming the reference for the moving diaphragm in a planar speaker.

**THD.** Abbreviation for total harmonic distortion. (See Distortion.)

**TIM.** Abbreviation for transient intermodulation distortion. (See Distortion.)

**Transducer.** Any of various devices that transmit energy from one system to another, sometimes one that converts the energy in form. Loudspeaker transducers convert electrical energy into mechanical motion.

**Transient.** Applies to that which lasts or stays but a short time. A change from one steady-state condition to another.

**Tweeter.** A small drive unit designed to produce only high frequencies.

**Wavelength.** The distance measured in the direction of progression of a wave, from any given point characterized by the same phase.

**White noise.** A random noise used in measurements, as it has the same amount of energy at each frequency.

**Woofers.** A drive unit operating in the bass frequencies only. Drive units in two-way systems are not true woofers but are more accurately described as being mid/bass drivers.

**MARTIN·LOGAN, LTD.**  
THE ELECTROSTATIC TECHNOLOGY

2001 delaware street  
p.o. box 707  
lawrence, kansas 66044  
ph: 913.749.0133