

DEPTH™ i

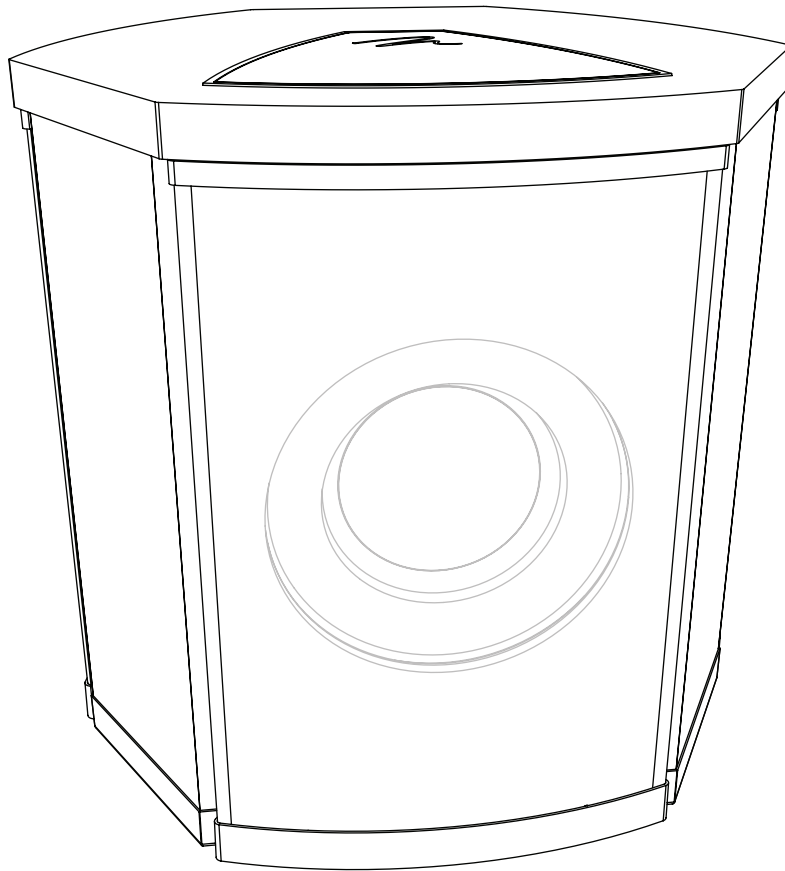

u s e r ' s m a n u a l

Serial Number _____

Record your serial numbers here for easy reference. You will need this information when filling out your warranty registration. Depth i's serial number is located near the bottom of the backplate and also on the shipping container.

Depth i Settings:

Level _____

25Hz Level _____

Phase _____

Low Pass Filter _____

High Pass Filter: Out _____

A/V Processor Bass Management Settings:

Main Speaker Size _____
(large recommended for full range speakers)

Center Speaker Size _____
(small recommended)

Surround Speaker Size _____
(small recommended)

Level _____

High-Pass _____

Low-Pass _____



The lightning bolt flash with arrowhead symbol, within an equilateral triangle, is intended to alert the user to the presence of uninsulated “dangerous voltage” within the product’s enclosure that may be of sufficient magnitude to constitute a risk of electric shock.



The exclamation point within an equilateral triangle is intended to alert the user to the presence of important operating and maintenance (servicing) instructions in the literature accompanying the appliance.



WARNING! Two people are required to move this subwoofer.

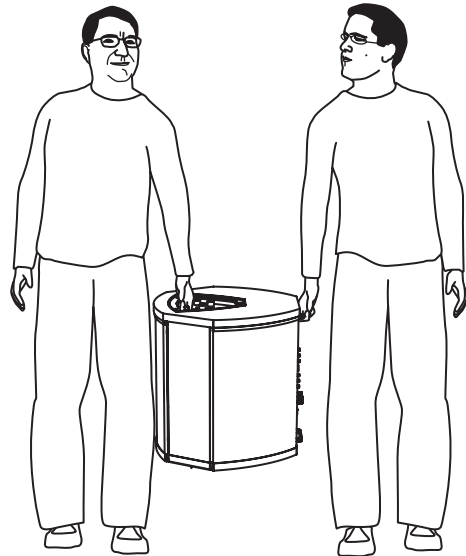

WARNING! Do not use your Depth i loudspeakers outside of the country of original sale—voltage requirements vary by country. Improper voltage can cause damage that will be potentially expensive to repair. The Depth i is shipped to authorized MartinLogan distributors with the correct power supply for use in the country of intended sale. A list of authorized distributors can be accessed at www.martinlogan.com or by emailing info@martinlogan.com.

Thank you—to you the MartinLogan owner,
for loving what we do,
and
for making it possible for us to do what we love.

CONTENTS & INTRODUCTION

Contents & Introduction	4
Installation in Brief	5
Controls and Connections	6
Accessing the Control Panel	
Control Panel	
Rear Connection Panel	8
2-Channel Mode	9
Multi-Channel Mode	10
2-Channel/Multi-Channel Mode	11
2-Channel Mode Using Speaker Level Inputs	12
2-Channel Mode With 2-Channel Output	13
Why the Filters Are Not Equal	
Sub Out—Using Multiple Subwoofers	14
AC Power Connection	15
Replacing the Fuse	
Break-In	
Placement	16
Listening Position	
Installing In A Cabinet	
Ask Your Dealer	
Enjoy Yourself	
Room Acoustics	17
Your Room	
Terminology	
Solid Footing	18
Home Theater	19
MartinLogan Exclusives	20
BalancedForce™ For Cleaner Bass	
TriLinear™ Configuration	
Servo-Controlled Dynamic Drivers	
Proprietary Switching Amplifier	
25Hz Level Control	
Frequently Asked Questions & Troubleshooting	21
Dimensioned Drawings	22
General Information	23
Specifications	
Warranty and Registration	
Serial Number	
Service	
Glossary of Audio Terms	24
Notes	26

Congratulations! You have invested in one of the world's premier subwoofers.

The MartinLogan Depth i represents the culmination of an intensive, dedicated research program directed toward creating a world class reference subwoofer using advanced technologies and without compromising durability, reliability, craftsmanship or aesthetics.

The Depth i subwoofer uses three custom 8-inch high-excursion drivers in a BalancedForce™, TriLinear™ configuration, which dramatically reduces cabinet vibrations, allowing deep, tight, well-defined bass. Servo-control woofer technology minimizes distortion. A proprietary digital amplifier drives the output stage with precision and extremely high efficiency. Low-pass filtering and phase control have been designed to make integrating the Depth i subwoofer with both MartinLogan and non-MartinLogan products both seamless and simple.

The materials in your new Depth i subwoofer are of the highest quality and will provide years of enduring enjoyment and deepening respect. The cabinetry is constructed from the highest quality composite material for acoustical integrity.

This User's Manual will explain in detail the operation of your Depth i subwoofer and the philosophy applied to its design. A clear understanding will help you obtain maximum performance and pleasure from this most exacting subwoofer system.



In accordance with the European Union WEEE (Waste Electrical and Electronic Equipment) directive effective August 13, 2005, we would like to notify you that this product may contain regulated materials which upon disposal, according to the WEEE directive, require special reuse and recycling processing.

For this reason MartinLogan has arranged with our distributors in European Union member nations to collect and recycle this product at no cost to you. To find your local distributor please contact the dealer from whom you purchased this product, email info@martinlogan.com or visit the distributor locator at www.martinlogan.com.

Please note, only this product itself falls under the WEEE directive. When disposing of packaging and other related shipping materials we encourage you to recycle these items through the normal channels.

We know you are eager to hear your new MartinLogan subwoofer, so this section is provided to allow fast and easy set up. Once you have your subwoofer operational, please take the time to read, in depth, the rest of the information in this manual. It will give you perspective on how to attain the greatest possible performance from this most exacting woofer system.

If you should experience any difficulties in the setup or operation of your MartinLogan subwoofer, please refer to the Room Acoustics and Placement sections of the this manual. Should you encounter a persistent problem that cannot be resolved please contact your authorized MartinLogan dealer. They will provide you with the appropriate technical analysis to alleviate the situation.



WARNING!

- Hazardous voltages exist inside—do not remove cover.
- Refer servicing to a qualified technician.
- To prevent fire or shock hazard, do not expose this module to moisture.
- Turn amplifier off and unplug subwoofer should any abnormal conditions occur.
- The power cord should not be installed, removed, or left detached from the speaker while the other end is connected to an AC power source.
- The main power switch near the AC inlet shall remain readily operable.
- No candles or other sources of open flame should be placed on the speaker.
- No liquids either in glasses or vases should be placed on speaker.
- Speaker should not be exposed to dripping or splashing liquids.
- The terminals marked with the lightning bolt symbol should be connected by an instructed person or by way of ready made terminals
- The power cord should remain readily operable should any abnormal conditions occur.

Step 1: Unpacking

Remove your new subwoofer from its packing. **Note:** Retain original packing materials for future use.

Step 2: Placement

Ideally, place the subwoofer in a corner near the front of the room. Please see the *Placement* section (page 16) for more details.

Step 3: Signal Connection

Use the best cables you can. High quality cables, available from your specialty dealer, are recommended and will give you superior performance.

Attach your preamplifier/processor outputs through cables to the signal input area located on the subwoofer's rear panel. Please see the *Controls and Connections* section (pages 6–15) for more details.

If you plan to connect your subwoofer using Speaker Level (high level) inputs, please refer to the *2-Channel Mode Using Speaker Level Inputs* section (page 12 for more details).

Step 4: Power Connection (AC) (see warning)

Make sure the level knob is set at 0. Plug the subwoofer into a wall outlet. Review the *AC Power Connection* section (page 15) of this manual for more details.

Step 5: Setting the Controls

- Set the Level knob to 3 or 4.
- Set the Power switch to 'Auto'.
- Set the 25Hz Level knob to 0.
- Set the Phase to 90°.
- Set the Low Pass Filter to the closest setting below the low-end frequency response of your main speakers.

These settings are only a beginning point. Your subwoofer will need proper setup to optimize performance. Please see the *Controls and Connections* section (pages 6–15) for more details.

Step 6: Listen and Enjoy

CONTROLS AND CONNECTIONS

Accessing the Control Panel

The control panel is located behind the inset metal plate located on top of the subwoofer. To access the control panel, gently press the area above the MartinLogan logo. When the spring releases gently pull the metal plate away from the subwoofer.

Control Panel

Level

Setting the level too high will cause the bass to seem bloated and is the single most common cause of bad sounding subwoofers. A rule of thumb is that the subwoofer should not draw attention to itself, but should simply make the system's low end seem more extended and accurate.

Low Pass Filter

When the Depth i is connected in multi-channel mode (via its LFE input), the low pass filter is not active and your processor handles the bass management. When connected

in 2-channel mode (via its speaker or line level left/right input), the low-pass filter is active.

As a general rule the Low Pass Filter should be set at the option approximately equal to (or below) 70% of your main speaker's lowest frequency response. Example: The MartinLogan Vista's lowest frequency response is 43Hz. 70% of 43Hz equals 30.1, so you should set the Depth i's low pass filter to 30Hz. Remember, this is a general rule. We advise that once you try the recommended setting using the formula above, you should try the surrounding settings to see which sounds best.

Optionally, an internal module in the Depth i can be upgraded with a custom tailored Low Pass Filter setting for use with the MartinLogan CLX loudspeaker. When this upgrade is implemented the 30 Hz setting on the Depth i becomes the CLX Low Pass Filter setting.

Phase Control

The phase control is entirely dependent on the size and

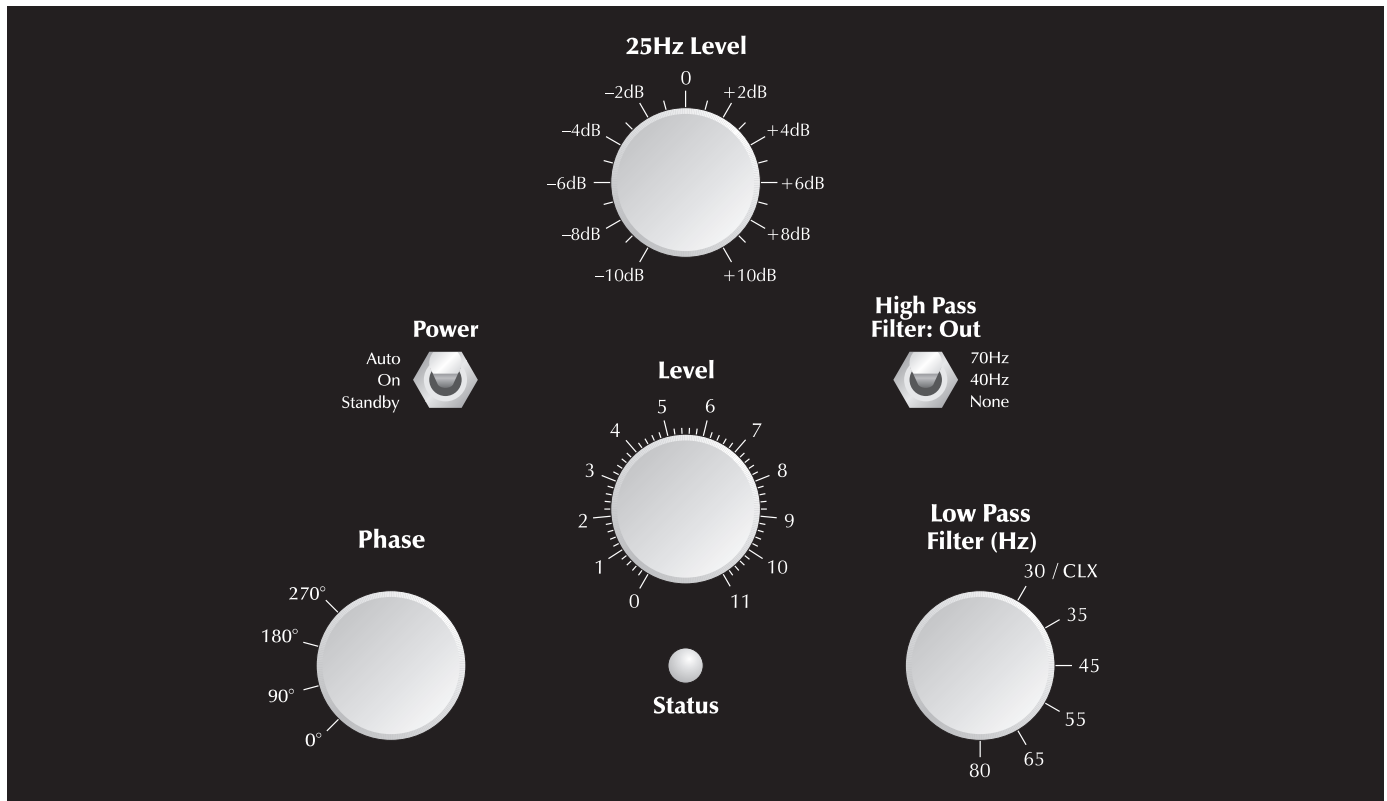

Figure 1. Top control panel.

configuration of your listening environment, the placement of the unit, and your seating arrangement. Due to the way bass sound waves develop in different rooms, there is no rule of thumb for setting phase. For instance, if your room has a peak at the subwoofer crossover area, you may wish to set the phase so the actual acoustic outputs of the subwoofer and main speakers are out of phase. Experiment, try different settings and be patient.

Power

The Auto/On/Standby switch controls Depth i's energy saving feature. When set to 'Auto', the Depth i will turn on when a music signal is detected and off when there is none. The 'On' setting prevents the Depth i from entering energy saving mode. The 'Standby' setting forces the Depth i into energy saving mode. While set to 'Standby', the Depth i will not operate.

25Hz Hz Level

The 25Hz Level knob significantly adjusts frequencies where peaks and dips of different amplitudes often manifest in real world environments. The ideal setting is dependent on room size and construction, system configuration and personal preference.

High Pass Filter: Out

The High Pass Filter: Out control filters the signal output from the Right Out and Left Out connections.

Status Light

See descriptions of the status light on page 8. The top control panel status light functions identically to the back plate status light.

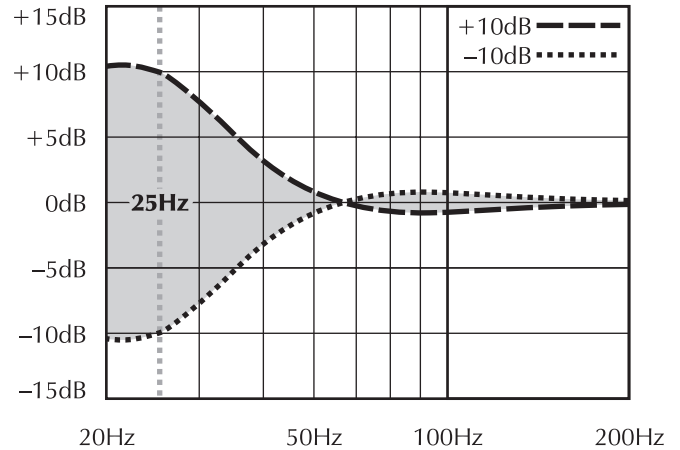

Figure 2. Graph demonstrating the frequencies effected by the 25Hz Level controls

Rear Connection Panel

Sub Out

For systems utilizing multiple subwoofers. Connect Sub Out to the LFE Input or Right In / Left In on additional sub(s).

Right Out / Left Out

Should only be used if connecting this sub between a pre-amp and amplifier. Connect to the Left In/Right In on the amplifier. The High Pass: Out control filters the output from these connections.

LFE In

Connect to LFE Out on your A/V processor. The subwoofers Low Pass Filter control does not effect this connection. Crossover settings for LFE In are controlled through the A/V processor.

Right In/Left In

Connect to Main-Out or Pre-Out on your receiver/pre-amp. Depth i's Low Pass Filter control effects the signal received through these inputs.

Speaker Level In

This set of binding posts provides a place to connect the subwoofer using standard speaker cable. Depth i's Low Pass Filter control effects the signal received through these inputs.

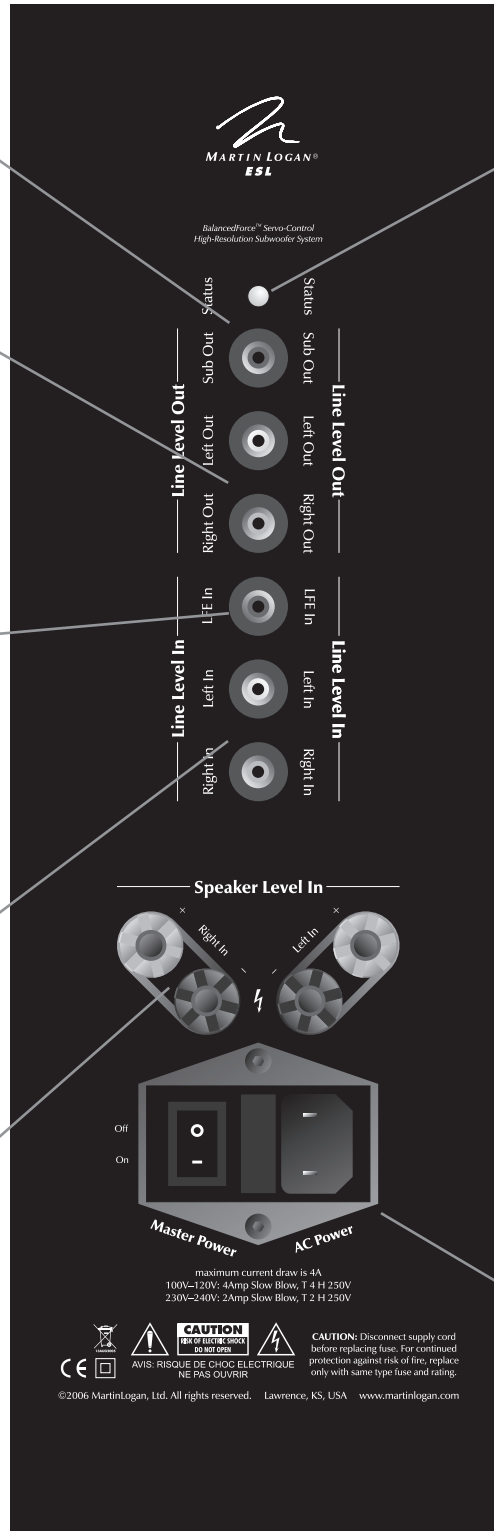

Status Light

The Depth i is equipped with a multi-color LED to indicate the current status of the woofers. The following list explains the meaning of the different colors:

No color: No power. The subwoofer is not plugged in, or the fuse has blown.

Green: Play mode. This indicates the subwoofer detects an audio signal and has automatically switched into play mode.

Yellow: Standby mode. This indicates the Power switch is set to Standby, or the sub has detected no audio signal for more than forty minutes and has automatically switched into standby mode.

Red: Initializing or Safe mode. This indicates that the subwoofer is initializing. This also indicates if the subwoofer temperature has exceeded nominal operating range. If the subwoofer overheats, please allow it to cool and reset it by unplugging the unit and plugging it back in.

AC Power Connection, Master Power Switch, & Fuse

maximum current draw is 4A
100V-120V: 4Amp Slow Blow, T 4 H 250V
230V-240V: 2Amp Slow Blow, T 2 H 250V

CAUTION Risk of electric shock. Do not open.
AVIS: RISQUE DE CHOC ELECTRIQUE. NE PAS OUVRIR.

CAUTION: Disconnect supply cord before replacing fuse. For continued protection against risk of fire, replace only with same type fuse and rating.

©2006 MartinLogan, Ltd. All rights reserved. Lawrence, KS, USA www.martinlogan.com

Figure 3. Rear connection panel.



WARNING! Turn the Master Power switch Off and unplug it before making or breaking any signal connections!

2-Channel Mode

This setup is recommended if your subwoofer will be used in a 2-channel only system. When a signal is connected to the subwoofers Left In/Right In, the Low Pass Filter control is active.

Signal Connection (see figure 4):

- 1 Connect the left out/right out from your preamp/receiver to the Left In/Right In of the subwoofer. Use quality RCA interconnects. If your preamp/receiver only has one set of outputs you need to obtain Y adapters from your dealer.

Recommended Control Settings (see figure 5):

- 1 Calculate the number equal to 70% of your main loudspeaker's lowest frequency rating. Set the Low Pass Filter switch to the closest setting below the resulting number.
- 2 Play familiar music with bass content. Increase the Level control until the music has deep extended bass. Be careful to avoid levels that become overwhelming.
- 3 Try the phase control in different settings until the best blending is obtained. If you are using the subwoofer to augment other MartinLogan products, we suggest starting with the phase set at 90°.
- 4 If you have completed steps 1–3 and still have weak or boomy bass, adjust the 25Hz Level knobs to compensate for these anomalies. Experiment with the controls and listen to the effects. Try to find a position that sounds correct to you. Experiment by changing the Level control while adjusting these knobs. Find a position that gives you deep extended bass and good blending with your main speakers.

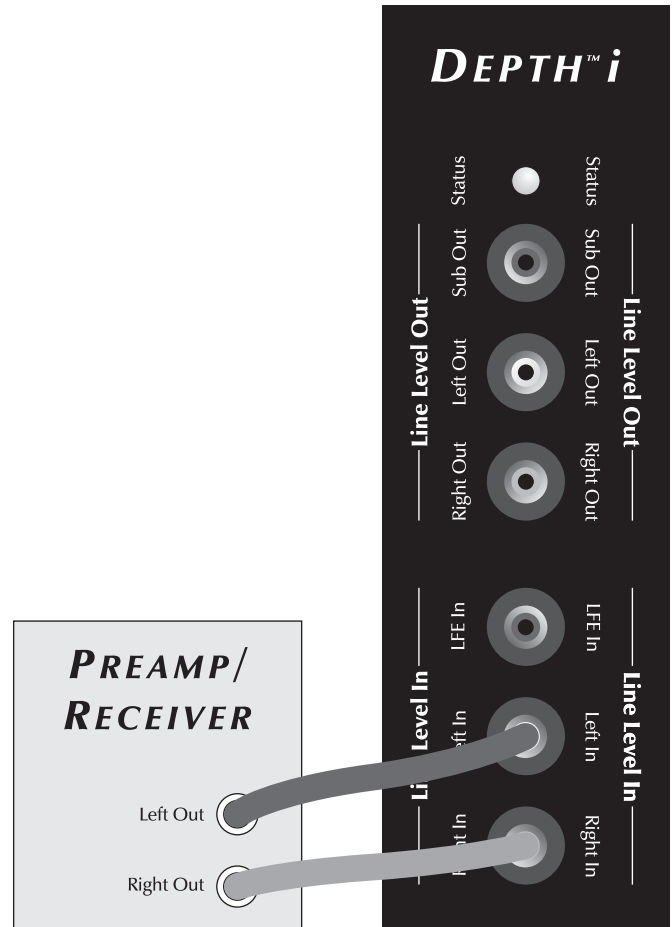

Figure 4. Signal connection for 2-channel mode.

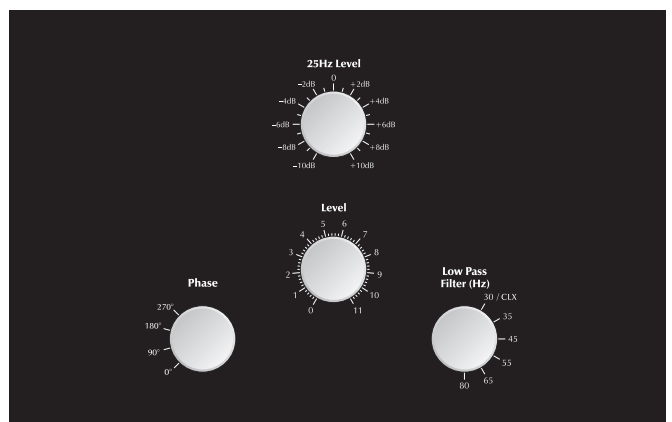

Figure 5. Adjust these controls for 2-channel mode.

Multi-Channel Mode

This setup is recommended if you will use your subwoofer in a dedicated home theater or multi-channel system. When a signal is connected to the subwoofer's LFE In, the Low Pass Filter control is NOT active. Your processor handles most of the bass management.

Signal Connection (see figure 6—RCA shown):

- 1 Connect the LFE out of the processor to the LFE In.



WARNING!

Based on the performance of most processors, it is recommended that MartinLogan center and effects type speakers (i.e. Stage, Cinema, Theater, and Script i) not be run in large, wide or full range mode. Doing so may potentially damage the speaker if the processor attempts to drive the speaker beyond its rated frequency range. This warning also applies to products from other manufacturers.

It is recommended to run center and effects type speakers in limited or narrow mode.

Recommended Control Settings (see figure 7):

- 1 With multi-channel source material playing, adjust the Level control to your preferred level.
- 2 Try the phase control in different settings until the best blending is obtained. If you are using the subwoofer to augment other MartinLogan products, we suggest starting with the phase set at 90°.
- 3 If you have completed steps 1–2 and still have weak or boomy bass, adjust the 25Hz Level knob to compensate for these anomalies. Increase and decrease to controls and listen to the effects. Try to find a position that sounds correct to you. Experiment by changing the Level control while adjusting these knobs. Find a position that gives you deep extended bass and good blending with your main speakers.
- 4 Follow the bass management setup instructions in your processor manual to fine-tune the subwoofer level.

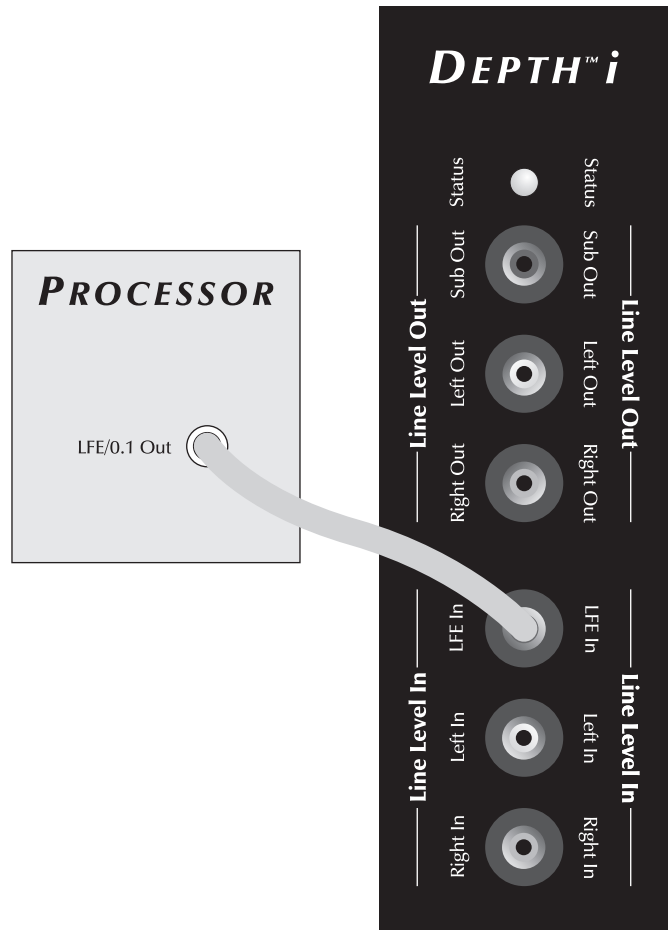

Figure 6. Signal connection for multi-channel mode.

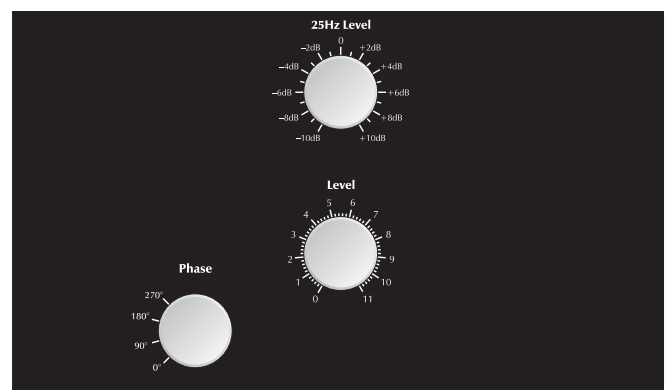

Figure 7. Control settings for multi-channel mode.

2-Channel/Multi-Channel Mode

This setup is recommended if your subwoofer will be used in both 2-channel mode and as a LFE channel in a multi-channel system. By following this setup, you will allow your processor to handle most of the bass management while running in multi-channel mode, and relinquish control of the low pass filter to the subwoofer when running in a 2-channel mode.

Signal Connection (see figure 8):

- 1 Connect the left and right out of your preamplifier to the subwoofer's Left In / Right In. Use quality RCA interconnects. If your preamplifier only has one set of outputs you need to obtain Y adapters from your dealer.
- 2 Connect the LFE output of the processor to the subwoofer's LFE In. Use quality RCA interconnects.

Recommended Control Settings (see figure 9):

- 1 Set your front speakers for wide, large or full mode in your processor. Set the center and effects type speakers in limited or narrow mode (see the warning on page 10).
- 2 Calculate the number equal to 70% of your main loudspeaker's lowest frequency rating. Set the Low Pass Filter switch to the closest setting below the resulting number.
- 3 While playing familiar music with bass content, turn the level control up until the music has deep bass that is not overwhelming.
- 4 Try the phase control in different settings until the best blending is obtained. If you are augmenting MartinLogan loudspeakers, we suggest you start with Phase set at 90°.
- 5 Use the bass management section of your processor's speaker setup to set the subwoofer level at an appropriate level. Follow the instructions in your processor's manual to fine-tune the subwoofer level.
- 6 If your processor offers the option to setup crossovers for a subwoofer, we recommend that you start with the following settings—Crossover: 70Hz, High-Pass: 12dB, and Low-Pass: 24dB. The optimal setting for these options may vary depending on your room and listening preferences.

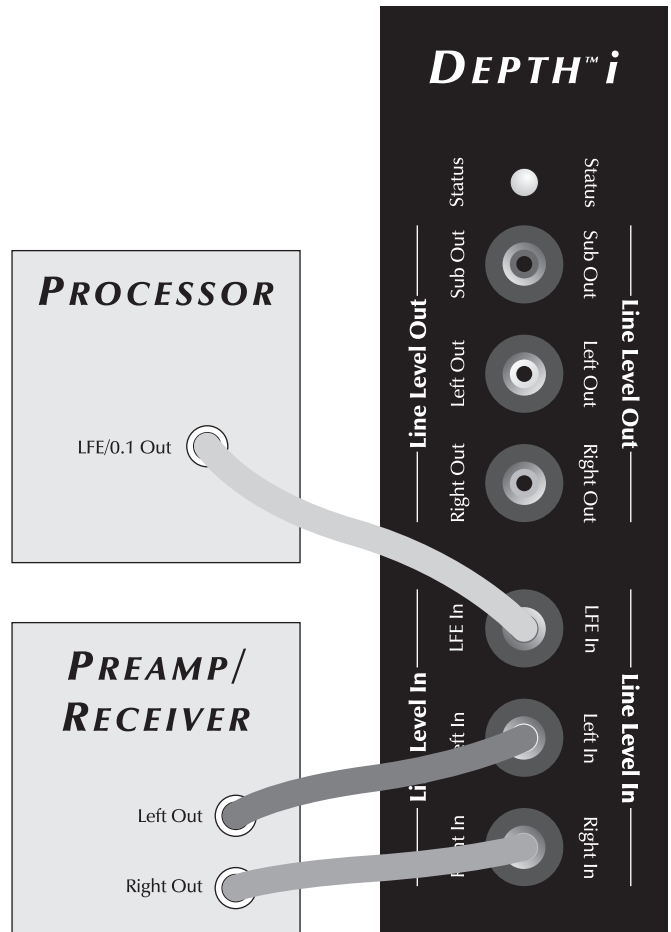

Figure 8. Signal connection for 2-channel/multi-channel mode.

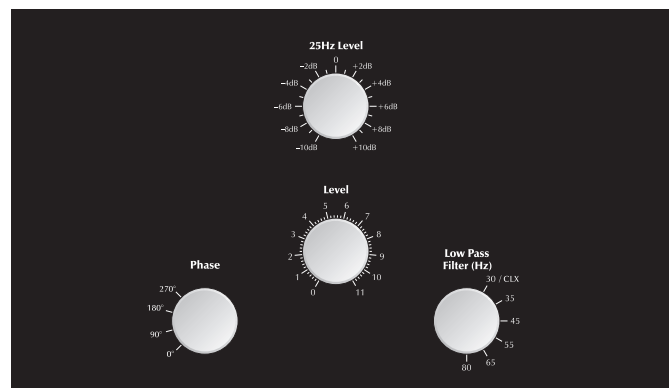

Figure 9. Control Settings for 2-channel/multi-channel mode.

2-Channel Mode Using Speaker Level Inputs

This setup is recommended if your subwoofer will be used in a 2-channel only system with full-range front loudspeakers. When a signal is connected to the subwoofer's Left In/Right In subwoofer's Low Pass Filter control is active.

Signal Connection (see figure 10):

- 1 Connect the left and right outputs of your amplifier to the subwoofer's high-level Speaker Level In (Left In/Right In) binding posts. Use quality speaker cable.

If your amplifier only has one set of outputs you may connect your amplifier to your speakers as normal and run an additional set of cables from your speakers to the subwoofer's Speaker Level In binding posts.

It is also possible to connect the left and right outputs of your amplifier to the left and right speaker level (high level) inputs of the subwoofer and run an additional set of cables from your subwoofer to the speakers.

Recommended Control Settings:

- 1 Set the controls as recommended on page 9.

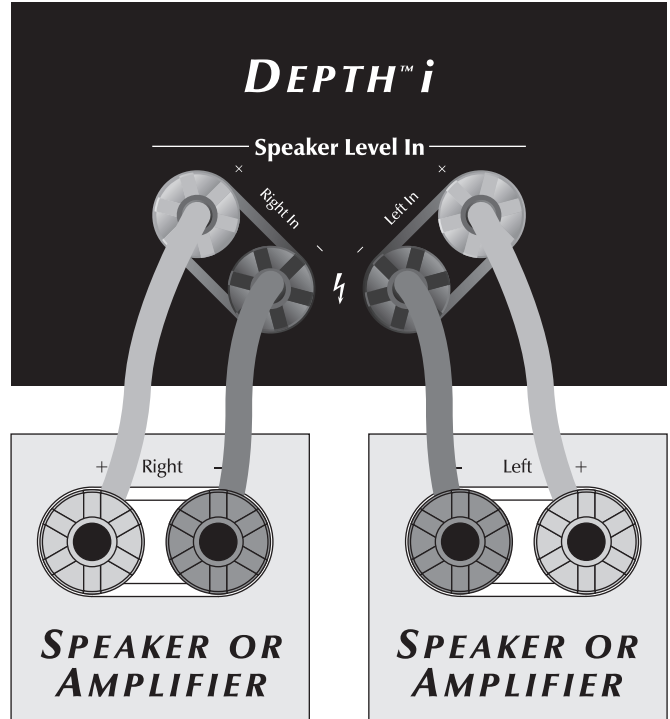

Figure 10. Signal connection for 2-channel mode using speaker level inputs.

2-Channel Mode With 2-Channel Output

This setup is recommended if your subwoofer will be used in a 2-channel only system.

Signal Connection (see figure 11):

- 1 Connect the left out/right out from your preamplifier to the Left In/Right In of the subwoofer. Use quality RCA interconnects.
- 2 Connect the Left Out/Right Out of your subwoofer to the left in/right in of your amplifier. Use quality RCA interconnects.

Recommended Control Settings:

- 1 Set the controls as recommended on page 9.
2. The High Pass Filter: Out switch should be set, at the user's discretion, to the option with the best sounding result. As a general rule, if your main loudspeakers are bookshelf speakers, set the High Pass Filter: Out to 70Hz. Likewise, 40Hz for floorstanding loudspeakers. Use 'None', if you want to pass an unaltered signal.
- 3 At this time the Low Pass Filter should be set to approximately 70% of your main loudspeakers lowest frequency response—make note of this number.

If the High Pass Filter: Out is set to 'None', the Low Pass Filter should remain at approximately 70% of your loudspeakers lowest frequency response.

If the High Pass Filter: Out is set to 40Hz, the Low Pass Filter should be set to 35Hz or 70%, whichever is greater.

If the High Pass Filter: Out is set to '70Hz', the Low Pass Filter should be set to 55Hz or 70%, whichever is greater.

Why the Filters Are Not Equal

You may have noticed the recommended setting procedure does not advise setting the Low Pass Filter and High Pass Filter: Out to the same frequency. Between 20Hz and 100Hz, as the subwoofers output decreases, the loudspeakers output increases. For a seamless crossover of these two slopes, the summation of their two values, at any given frequency, should add to maintain a level output. By correctly setting your High Pass Out and Low Pass filters, this result can easily be achieved (see figure 12).

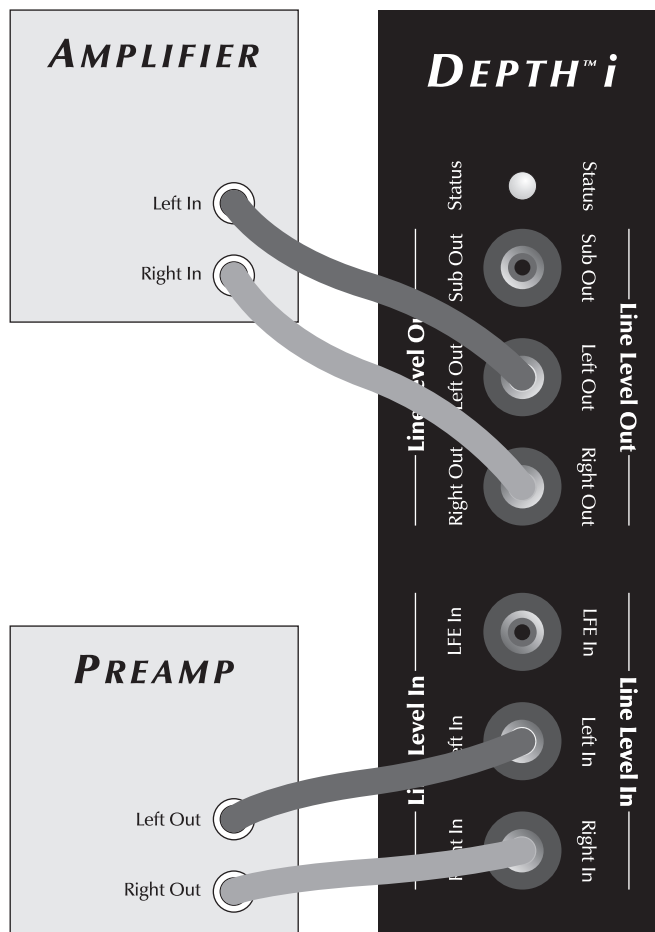

Figure 11. Signal connection for 2-channel mode with 2-channel output.

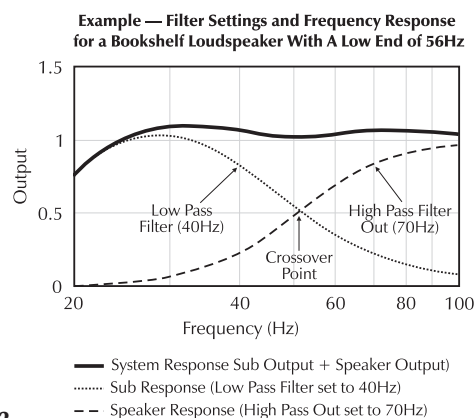

Figure 12.

Sub Out—Using Multiple Subwoofers

Using Sub Out offers an easy way to implement multiple subwoofers in your audio/video system.

Note: Additional subwoofers must run as either dedicated 2-channel (stereo) or multi-channel (LFE) subwoofers, but not both.

Signal Connection:

- 1 Connect the first subwoofer to your system using one of the five modes previously described.
- 2 Connect the Sub Out of the first subwoofer to either the LFE In or the Right (or Left) In of the next subwoofer. Use quality RCA interconnects.

Connecting to the LFE In allows additional subwoofers to perform as dedicated LFE channels (see figure 13).

Connecting to the Right (or Left) In allows additional subwoofers to perform as dedicated 2-channel subwoofers (see figure 14).

- 3 Repeat step 2 for each additional subwoofer in the chain using the same input for every additional connection.

Recommended Control Settings:

- 1 Adjust the control settings of the first subwoofer using one of the five modes previously described.
- 2 Adjust the control settings of each additional subwoofer. Use the method used to adjust the first subwoofer.

Note: While the settings of each subwoofer should be similar, you will probably find that each sub will need to be tweaked for optimal performance because of its unique room placement.

Regardless of how you use your subwoofer, experimentation can often result in better sound. Don't be afraid to try different settings. You can always return the controls to their previous settings.

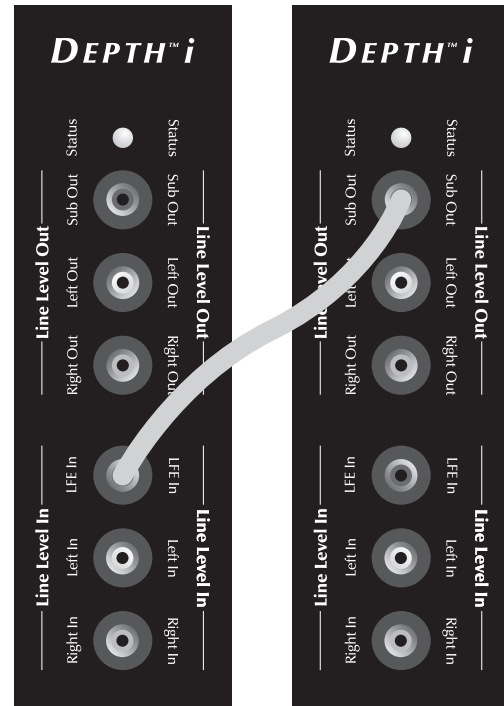

Figure 13. Using multiple Depth i. LFE option. Primary sub on right. Additional sub on left.

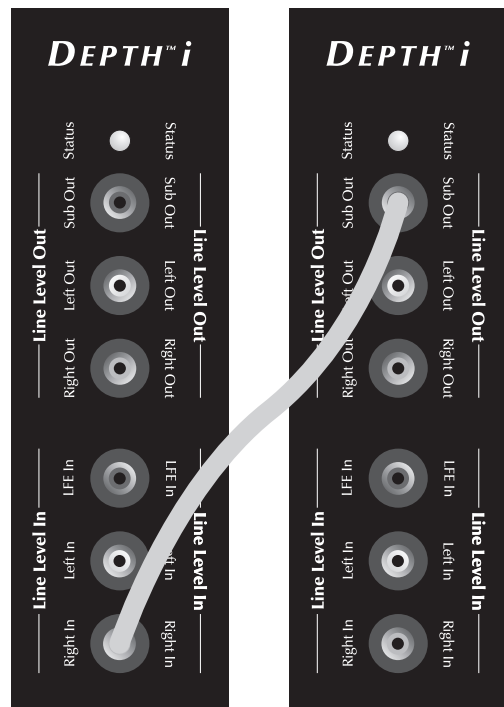

Figure 14. Using multiple Depth i. Right/Left option.. Primary sub on right. Additional sub on left.

AC Power Connection



WARNING! The power cord should not be installed, removed, or left detached from the subwoofer while the other end is connected to an AC power source.

The IEC cord should be firmly inserted into the AC power receptacle on the rear connection panel of the subwoofer, then to any convenient AC wall outlet. Directly adjacent to the AC power receptacle on the rear connection panel of the subwoofer is a master power switch. This switch is wired directly to the AC main and turns on/off all power going to the subwoofer. The Depth i also integrates a signal sensing power supply that will go to Standby mode after a few minutes of no music signal if the front-panel power switch is set to 'Auto'.

Your subwoofer is wired for the power service supplied in the country of original consumer sale. The AC power rating applicable to a particular unit is specified both on the packing carton and on the serial number plate attached to the subwoofer.

If you remove your subwoofer from the country of original sale, be certain that AC power supplied in any subsequent location is suitable before connecting and operating the subwoofer. Substantially impaired performance or severe damage may occur to the subwoofer if operation is attempted from an incorrect AC power source.

Replacing the Fuse

If the fuse in your subwoofer should require changing, turn your subwoofer off and unplug it before removing the fuse. Replace the bad fuse (figure 15) with a matching T 4A H 250V (T 2A L H 250V if you are in a region using 230v–240v mains voltage).

Break-In

Our custom made woofers require approximately 50 hours of break-in at moderate listening levels before their optimal performance occurs. This will factor in on any critical listening and judgment.

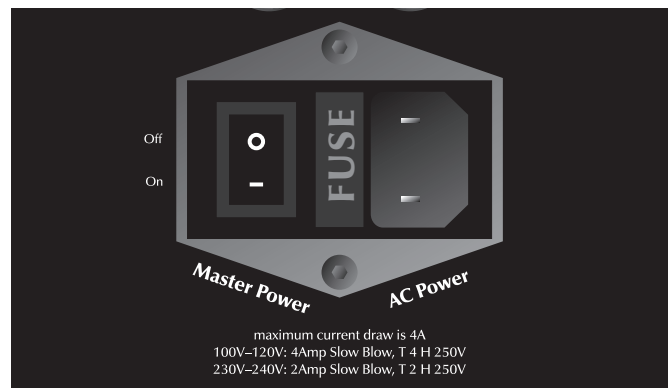

Figure 15. Depth i's Master Power switch, Fuse, and AC Power receptacle.

PLACEMENT

Listening Position

Generally, subwoofers have the most output when placed in the corner of a room. However, this can also exaggerate the subwoofers output making blending difficult. We recommend starting by placing the subwoofer in a corner. It should be placed in such a way that there are 2 inches between the grill and the wall. This will avoid blocking the output of any woofers. If, after the full range of tuning techniques have been employed, the subwoofer sounds like it has too much upper bass energy try pulling it away from the wall, toward the listening position. This will lessen the reinforcement of these problematic frequencies from the wall and likely smooth out the response. Repeat the setup procedure with the woofer controls after you move it (see figure 16).

Installing in a Cabinet

It is common for people to place their subwoofer(s) inside of cabinetry. The Depth i's unique, three-woofer design does not compromise the ability to be successfully installed in such a configuration. However, it is recommended, as with any quality multi-driver subwoofer, that there be a minimum of three inches of open space between the cabinet and the front, left and right sides (see figure 17).

Ask Your Dealer

Your MartinLogan dealer can suggest many options for optimal subwoofer placement. They also have many tools at their disposal, such as experience, familiarity with the associated equipment, and even sound analysis equipment which may make the task of determining optimal subwoofer placement easier.

Enjoy Yourself

The Depth i is a very refined subwoofer and will benefit from care in setup. With the above placement tips in mind you will find, over months of listening, that small changes can result in measurable differences. As you live with your subwoofer, do not be afraid to experiment with positioning until you find the optimal relationship between your room, settings, and subwoofer that gives to you the best results. Your efforts will be rewarded.

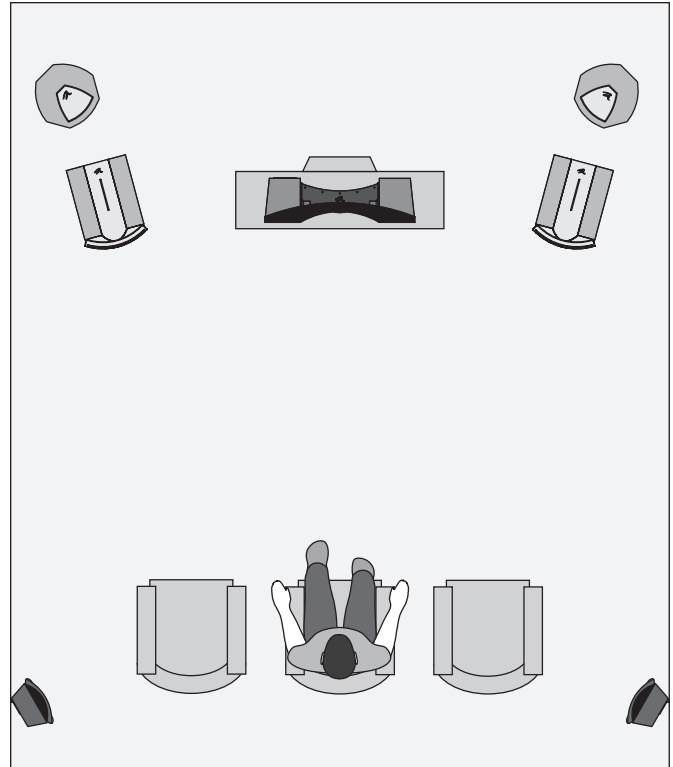

Figure 16. Depth i Subwoofers as the LFE (effects) channels, MartinLogan Summit speakers as front channels, MartinLogan Stage as the center channel, MartinLogan Script i as side surround (effects) channels. Note the corner placement of the Depth i at the front of the listening room.

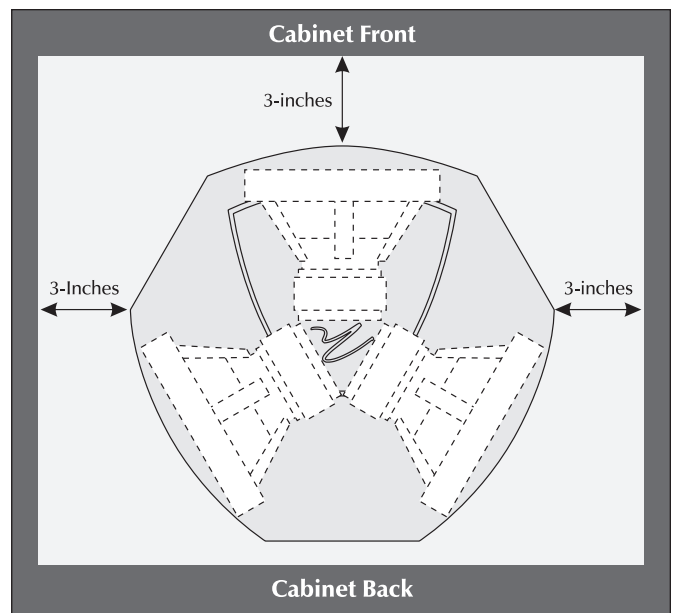

Figure 17. Placing the Depth i in a cabinet requires a minimum of three inches of open space on the front, left and right.

Your Room

This is an area that requires both a little background to understand and some time and experimentation to attain the best performance from your system.

Your room is actually a component and an important part of your system. This component is a large variable and can dramatically add to or subtract from a great sonic experience.

All sound is composed of waves. Each frequency has its own wave size, with the lower, or bass frequencies literally encompassing from 10 feet to as much as 40 feet. Your room participates in this wave experience like a swimming pool with waves reflecting and becoming enhanced depending on the size and shape of the room and the types of surfaces in the room.

Remember that your audio system can actually generate all of the information required to recreate a sonic event in time, space, and tonal balance. Acoustically, the role of an ideal room would be to neither delete nor contribute to that information. However, nearly every room does to some degree.

Terminology

Standing Waves

Sound coming from a subwoofer bounces around in a room until a pattern emerges—this is called a standing wave. Typically, this is only a problem with frequencies below 100Hz. When this happens different parts of your room experience either an excess or a lack of bass.

Some people believe that having a room without parallel walls will eliminate this effect. The truth is that non-parallel walls only generate different standing wave patterns than those that occur in rectangular rooms.

Usually, you can excite most of the standing waves in a room by putting the subwoofer in a corner. Listening position determines which standing waves you will experience. For instance, if you sit in a corner you will hear most of the standing waves. This can be an overpowering experience. Sitting next to a wall can also intensify the levels of the standing waves that are experienced.

Resonant Surfaces and Objects

All of the surfaces and objects in your room are subject to the frequencies generated by your system. Much like an instrument, they will vibrate and "carry on" in syncopation with the music, and may contribute in a negative way to the sound. Ringing, boominess, and even brightness can occur simply because surfaces and objects are "singing along" with your speakers.

Resonant Cavities

Small alcoves or closet type areas in your room can be chambers that create their own "standing waves" and can drum their own "one note" sounds.

Solid Footing

After living and experimenting with your subwoofer, you may want to use ETC (energy transfer coupler) spikes supplied with the subwoofer (see figure 18). With the use of these spikes, the subwoofer will become more firmly planted on the floor and, consequently, bass will tighten and imaging will become more coherent and detailed. It is best not to implement the spikes, however, until you are secure in the positioning, as the spikes can damage the floor if the speaker is moved. The feet that attach to the bottom of the Depth i use a common $\frac{3}{8}$ - 16 thread.

Spike Installation Instructions:

- 1 On a soft, padded surface, carefully lay your subwoofer on its side to gain access to the bottom.
- 2 Remove existing feet or spikes. Thread new spikes into holes and screw them in all of the way. If the subwoofer does not sit level loosen one spike until level is achieved.
- 3 By hand, tighten the jam nut snugly against the cabinet. Do not over tighten the nut.
- 4 Right the speaker.

Caution: Make sure your hands and any cabling are clear of the spikes. Do not slide subwoofer as spikes are sharp and can damage your floor or carpet.

- 5 Adjust to level by rotating spikes. By hand, tighten the jam nut snugly against the cabinet when you are satisfied that subwoofer is level.

Caution: Walking the subwoofer may result in a broken spike.

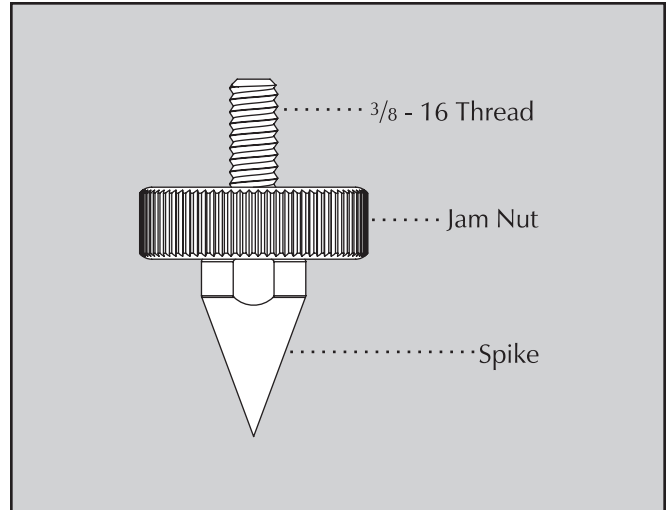

Figure 18. The ETC™ Spike.

It had long been the practice of stereo buffs to connect their television to the stereo system. The advantage was the use of the larger speakers and more powerful amplifier of the stereo system. Even though the sound was greatly improved, it was still mono and limited by the broadcast signal.

In the late 1970's and early '80's two new home movie formats became widely available to the public: VCR and laser disc. At the same time video screen sizes began increasing.

By 1985, both formats had developed into very high quality audio/video sources. In fact, the sonic performance of some video formats exceeded audio-only formats. Now, with theater quality sound available at home, the only element missing was the "surround sound" presentation found in movie houses.

Fortunately, "Dolby" and "DTS" encoded material (which include almost all movies) have the same surround sound information encoded on home releases as the theater films. All that is required to retrieve this information is a decoder, additional speakers, subwoofer(s) and amps to reproduce it.

Home theater is a complex purchase and we recommend that you consult your local MartinLogan dealer, who is well versed in this subject.

Each piece of a surround system can be purchased separately. Take your time and buy quality. No one has ever complained that the movie was too real. The following list and descriptions will only give you a brief outline of the responsibilities and demands placed on each speaker.

Front Left and Front Right

If these speakers will also be the same two used for your stereo playback then they should be of very high quality and able to play loud (over 102 dB) and reproduce bass below 80 Hz.

Center Channel

Many experts believe this to be the most important speaker in a home theater system, as almost all of the dialogue and a large portion of the front speaker information is reproduced by the center channel. It is important that the same manufacturer of the front speakers design the center speaker and that it is recommended for use as a center speaker. This is not the place to cut corners.

Surround Speakers

The surround, or effect speakers contain critical information. In films, sound effects are vital to the director in delivering a complete experience and the rapid technical increase in the discreet capacity of these effects channels has made their quality vital. This is equally true in music play back because of the emerging high definition, multi-channel music only formats. Full range instruments, voices and ambient queues are being routed to the effects channel. In the past, some may have suggested that this was the place to save money by purchasing small inexpensive speakers. If you choose to do so, be prepared to upgrade in the future.

Subwoofer

With any good surround system you will need one or more high quality subwoofers (the .1, in a 5.1 channel surround system). Most movie soundtracks contain large amounts of bass as part of the special effects. Good subwoofers will provide a foundation for the rest of the system.

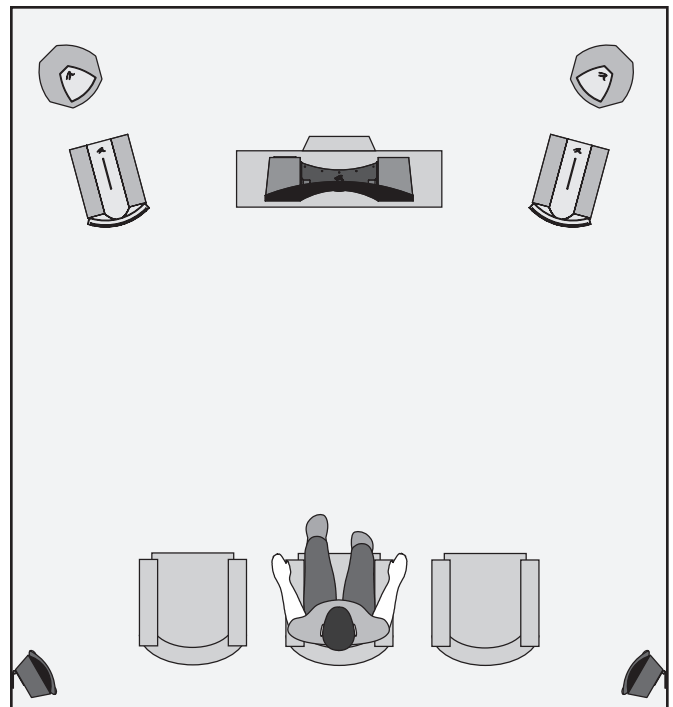

Figure 19. Summit speakers as front channels, the Stage as the center channel, Script i speakers as side surround (effects) channels, and Depth i subwoofers as LFE (effects) channel.

BalancedForce™ For Cleaner Bass

Resulting from an equal and opposite reaction to the cone's movement, strong bass causes all traditional subwoofer enclosures to generate acoustic vibrations. You feel this by touching the cabinet. Although the "physics" of this phenomenon actually cause a subwoofer cabinet to resonate or even dance, most subwoofer designers apply weight or mass to the cabinet to minimize such disturbances, but still leave one by product—"smeared bass". Vibrations translated from the woofer to the cabinet actually dampen the bass signal causing a loose and "fuzzy" sound.

The Depth i integrates BalancedForce bass configuration to nullify cabinet vibrations. Originally engineered for the cost-no-object, state-of-the-art Statement™ E2 system, BalancedForce uses two or more drivers mounted at opposing angles. The Depth i's 3 drivers, spaced 120 degrees apart, operate in exact opposition, resulting in maximum cancellation delivering the ideal—pure bass energy with a reduction in cabinet contributions to the room as high as 25dB over traditional subwoofer resonance solutions!

TriLinear™ Configuration

The use of three small, identical drivers maintains the low distortion levels and optimal control of an efficient and rigid small driver while moving the same amount of air as a driver three times larger. This allows powerful bass in a small package, free from the performance limitations of a heavy and hard to control single large driver.

Servo-Controlled Dynamic Drivers

All dynamic drivers generate distortion caused by spider and surround nonlinearities as well as voice coil inductive disturbances and variant motor strength during massive woofer excursions. These challenges plague all subwoofer designers. The result? Induced harmonic and intermodulated distortions causing dramatic disturbances at high excursions. This occurs significantly in almost all non-servo-controlled subwoofers.

MartinLogan's advanced servo system uses a sophisticated monitoring and control circuit to detect and instantaneously correct any deviation between acoustical output and electrical input. The result? A reduction in distortion for the purest possible low-frequency reproduction.

Proprietary Switching Amplifier

The Depth i incorporates a proprietary switching amplifier that allows for an incredible amount of woofer control resulting in tighter, better defined bass and while keeping distortion at the lowest possible levels.

25Hz Level Control

The Depth i 25Hz Level controls allows custom sound tailoring capabilities found in few subwoofers. A room, especially when small, can greatly exaggerate bass in the 20–60Hz range. The Depth i's 25Hz Level control knob increases or decreases lower bass to compensate for these room anomalies and allows increased deep bass if you desire a subsonic sense of energy at the lowest frequencies.

FREQUENTLY ASKED QUESTIONS & TROUBLESHOOTING

Frequently Asked Questions

How do I clean my subwoofer?

Use a dust free cloth or a soft brush to clean your subwoofer. We recommend a specialty cloth (available through the Xtatic shop at www.martinlogan.com) that cleans better than anything else we have tried.

Is it safe to set things on my subwoofer?

While your subwoofer is designed with a durable, stain-resistant surface, we advise you not to set anything on your subwoofer—especially containers holding liquids.

Is there likely to be any interaction between my subwoofer and the CRT television in my Audio/ Video system?

Yes. The subwoofer doesn't use a shielded driver. We recommend 3 feet between the subwoofer and video components that are susceptible to magnetic fields.

Will my electric bill go 'sky high' by leaving my subwoofer plugged in all the time?

No. The subwoofer, when the power switch is set to 'Auto' or 'Standby', will draw about 15 watts when idle.

Should I unplug my subwoofer during a thunderstorm?

Yes, or before. It's a good idea to disconnect all of your audio/video components during stormy weather.

Troubleshooting

No Output

- Check that all your system components are turned on.
- Check that the master power switch adjacent to the AC receptacle is set to 'On'.
- Check that the power switch on the subwoofer is set to either 'Auto' or 'On'.
- Check your wires and connections.
- Check all interconnecting cables.
- Make sure the level control is not turned down.
- Turn off and unplug the Depth i and check the fuse near the AC power cord receptacle on the back. If the fuse has blown, replace the bad fuse with a matching T 4A H 250V fuse (T 2A L H 250V if you are in a region using 230v–240v current).
- If the problem persists, contact your dealer.

Muddy Bass

- Check placement. Try moving the subwoofer closer to the front and side walls.
- Check the type of feet that are being used. Try installing the ETC spikes.
- Decrease the level.
- Check your processor setup.
- If the problem persists, contact your dealer.

Hums or Unusual Sounds

- Turn the subwoofer off, unplug all signal inputs, turn the subwoofer back on and turn up the level. If the problem disappears, the hum is originating elsewhere in your system.
- Connect the subwoofer's AC connection to the same AC circuit as the pre amp.
- If the problem persists, contact your dealer.

DIMENSIONAL DRAWINGS

Plan View (Top)

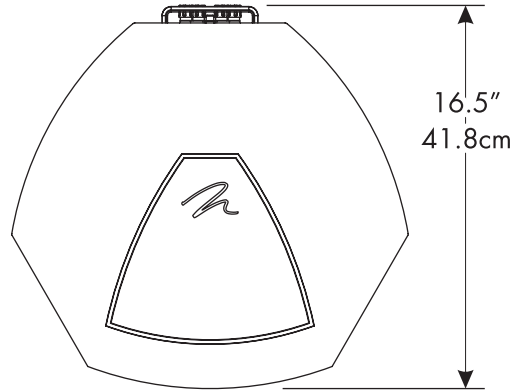

Front Elevation

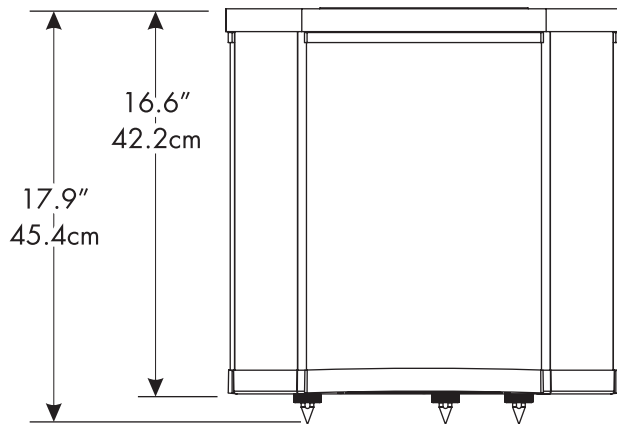

Back Elevation

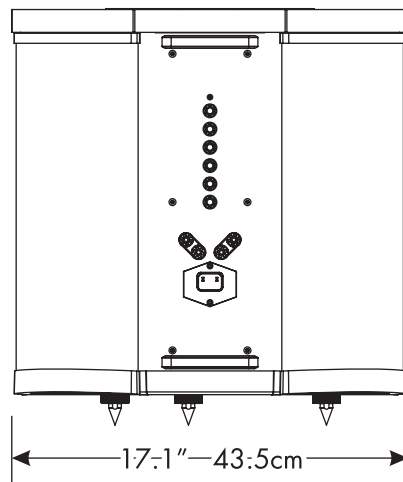

Side Elevation

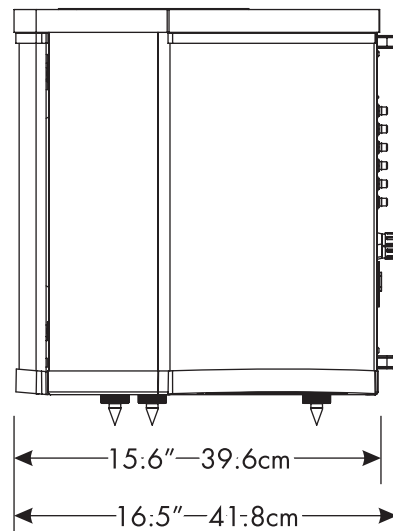

Specifications*

System Frequency Response

20–120 Hz \pm 3 dB. Anechoic through the LFE effects input.

Low Pass Filter Frequencies

30, 35, 45, 55, 65, 80Hz

High Pass Filter Frequencies

Bypass, 40Hz, 70Hz

Phase

0°, 90°, 180°, 270°

25Hz Level

\pm 10dB

Power

On, Auto, Standby

Components

3 \times 8" (20.3cm) high-excursion, aluminum cone with extended throw driver assembly, sealed non-resonant asymmetrical chamber format

Amplifiers

350W (at < 0.5% THD)

900W (peak)

Inputs

Left/Right RCA Line Level, RCA LFE, Speaker Level

Output

RCA Sub Out (all inputs summed), RCA Right/Left (with High Pass Filter)

Input Impedance

20,000 Ohms

Power Draw

Max: 300 Watts; Idle: 15 Watts; Standby: 10 Watts

Weight

70 lbs. each (31.8 kg)

Size

17.9" inches H \times 17.1" inches W \times 16.5" inches D
(45.4cm H \times 43.5cm W \times 41.8cm H)

*Specifications are subject to change without notice.

Warranty and Registration

Your subwoofer is provided with an automatic Limited 90 Day Warranty coverage. You have the option, at no additional charge, to receive Limited 3-Year Warranty coverage. To obtain the Limited 3-Year Warranty coverage you need to complete and return the Certificate of Registration, included with your subwoofer, and provide a copy of your dealer receipt, to MartinLogan within 30 days of purchase.

For your convenience MartinLogan also offers online warranty registration at www.martinlogan.com.

MartinLogan may not honor warranty service claims unless we have a completed Warranty Registration card on file! If you did not receive a Certificate of Registration with your new subwoofer you cannot be assured of having received a new unit. If this is the case, please contact your authorized MartinLogan dealer.

Serial Number

Depth i's serial number is located near the bottom of the backplate. Each individual unit has a unique serial number.

Service

In the rare event that your MartinLogan product should require service please contact the dealer from whom the product was purchased. In most cases your dealer will be able to assist you in troubleshooting and resolving the issue. If the dealer is unable resolve the issue or if there is no local dealer in your area contact MartinLogan customer service directly by using the service request form at www.martinlogan.com or by calling 785-749-0133.

Before returning any product to MartinLogan for service first contact the service department for an RMA number. Incoming shipments will only be accepted if labeled with a MartinLogan issued RMA number.

Before returning this product to MartinLogan for service first contact the service department to receive a shipping kit which will include packing straps and packing instructions.

Should you be using a MartinLogan product in a country other than the one in which it was originally purchased, please note the following:

- 1 The appointed MartinLogan distributor for any given country is responsible for warranty servicing only on units distributed by or through it in that country in accordance with its applicable warranty.
- 2 Should a MartinLogan product require servicing in a country other than the one in which it was originally purchased the end user may seek to have repairs performed by the nearest MartinLogan distributor, subject to that distributor's local servicing policies. All cost of repairs (parts, labor, transportation) must be born by the owner of the MartinLogan product.
- 3 If, after owning your MartinLogan product for six months, you relocate to a country other than the one in which it was purchased, your warranty may be transferable. Contact MartinLogan for details.

GLOSSARY OF AUDIO TERMS

AC. Abbreviation for alternating current.

Active crossover. Uses active devices (transistors, IC's, tubes) and some form of power supply to operate.

Amplitude. The extreme range of a signal. Usually measured from the average to the extreme.

Arc. The visible sparks generated by an electrical discharge.

Bass. The lowest frequencies of sound.

Bi-Amplification. Uses an electronic crossover, or line-level passive crossover, and separate power amplifiers for the high and low frequency loudspeaker drivers.

Capacitance. That property of a capacitor which determines how much charge can be stored in it for a given potential difference between its terminals, measured in farads, by the ratio of the charge stored to the potential difference.

Capacitor. A device consisting of two or more conducting plates separated from one another by an insulating material and used for storing an electrical charge. Sometimes called a condenser.

Clipping. Distortion of a signal by its being chopped off. An overload problem caused by pushing an amplifier beyond its capabilities. The flat-topped signal has high levels of harmonic distortion which creates heat in a loudspeaker and is the major cause of loudspeaker component failure.

CLS. The abbreviation for curvilinear linesource.

Crossover. An electrical circuit that divides a full bandwidth signal into the desired frequency bands for the loudspeaker components.

dB (decibel). A numerical expression of the relative loudness of a sound. The difference in decibels between two sounds is ten times the Base 10 logarithm of the ratio of their power levels.

DC. Abbreviation for direct current.

Diffraction. The breaking up of a sound wave caused by some type of mechanical interference such as a cabinet edge, grill frame or other similar object.

Diaphragm. A thin flexible membrane or cone that vibrates in response to electrical signals to produce sound waves.

Distortion. Usually referred to in terms of total harmonic distortion (THD) which is the percentage of unwanted harmonics of the drive signal present with the wanted signal. Generally used to mean any unwanted change introduced by the device under question.

Driver. See transducer.

Dynamic Range. The range between the quietest and the loudest sounds a device can handle (often quoted in dB).

Efficiency. The acoustic power delivered for a given electrical input. Often expressed as decibels/watt/meter (dB/w/m).

ESL. The abbreviation for electrostatic loudspeaker.

Headroom. The difference, in decibels, between the peak and RMS levels in program material.

Hybrid. A product created by the marriage of two different technologies. Meant here as the combination of a dynamic woofer with an electrostatic transducer.

Hz (Hertz). Unit of frequency equivalent to the number of cycles per second.

Imaging. To make a representation or imitation of the original sonic event.

Impedance. The total opposition offered by an electric circuit to the flow of an alternating current of a single frequency. It is a combination of resistance and reactance and is measured in ohms. Remember that a speaker's impedance changes with frequency, it is not a constant value.

Inductance. The property of an electrical circuit by which a varying current in it produces a varying magnetic field that introduces voltages in the same circuit or in a nearby circuit. It is measured in henrys.

Inductor. A device designed primarily to introduce inductance into an electrical circuit. Sometimes called a choke or coil.

Linearity. The extent to which any signal handling process is accomplished without amplitude distortion.

Midrange. The middle frequencies where the ear is the most sensitive.

Passive crossover. Uses no active components (transistors, IC's, tubes) and needs no power supply (AC, DC, battery) to operate. The crossover in a typical loudspeaker is of the passive variety. Passive crossovers consist of capacitors, inductors and resistors.

Phase. The amount by which one sine wave leads or lags a second wave of the same frequency. The difference is described by the term phase angle. Sine waves in phase reinforce each other; those out of phase cancel.

Pink noise. A random noise used in measurements, as it has the same amount of energy in each octave.

Polarity. The condition of being positive or negative with respect to some reference point or object.

RMS. Abbreviation for root mean square. The effective value of a given waveform is its RMS value. Acoustic power is proportional to the square of the RMS sound pressure.

Resistance. That property of a conductor by which it opposes the flow of electric current, resulting in the generation of heat in the conducting material, usually expressed in ohms.

Resistor. A device used in a circuit to provide resistance.

Resonance. The effect produced when the natural vibration frequency of a body is greatly amplified by reinforcing vibrations at the same or nearly the same frequency from another body.

Sensitivity. The volume of sound delivered for a given electrical input.

Stator. The fixed part forming the reference for the moving diaphragm in a planar speaker.

THD. The abbreviation for total harmonic distortion. (See Distortion)

TIM. The abbreviation for transient intermodulation distortion.

Transducer. Any of various devices that transmit energy from one system to another, sometimes one that converts the energy in form. Loudspeaker transducers convert electrical energy into mechanical motion.

Transient. Applies to that which lasts or stays but a short time. A change from one steady-state condition to another.

Tweeter. A small drive unit designed to reproduce only high frequencies.

Wavelength. The distance measured in the direction of progression of a wave, from any given point characterized by the same phase.

White noise. A random noise used in measurements, as it has the same amount of energy at each frequency.

Woofers. A drive unit operating in the bass frequencies only. Drive units in two-way systems are not true woofers but are more accurately described as being mid/bass drivers.

NOTES



WARNING! Do not use your Depth i loudspeakers outside of the country of original sale—voltage requirements vary by country. Improper voltage can cause damage that will be potentially expensive to repair. The Depth i is shipped to authorized MartinLogan distributors with the correct power supply for use in the country of intended sale. A list of authorized distributors can be accessed at www.martinlogan.com or by emailing info@martinlogan.com.



2101 Delaware Street, Lawrence, Kansas 66046, USA tel 785.749.0133 fax 785.749.5320 www.martinlogan.com