

FEATURE™

Fully Powered Hybrid Electrostatic Loudspeaker

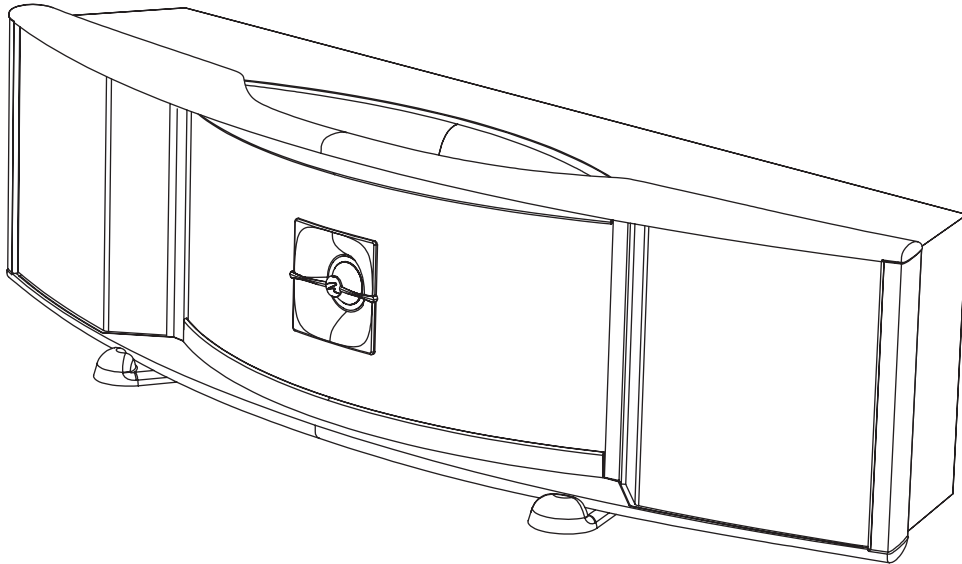

u s e r ' s m a n u a l



Serial Number: _____
Record your serial number here for easy reference. You will need this information when filling out your warranty registration. Feature's serial number is located on backplate and on the shipping container.

This device complies with part 15 of the FCC Rules. Operation is subject to the following two conditions: (1) This device may not cause harmful interference, and (2) this device must accept any interference received, including interference that may cause undesired operation.

Thank you—the MartinLogan owner,
for loving what we do,
and
making it possible for us to do what we love.

CONTENTS

Contents	4	MartinLogan Exclusives	13
Installation in Brief.	5	CLST™ (Curvilinear Line Source)	
Introduction	6	Generation 2 Diaphragm	
Connections	7	MicroPerf Stator	
AC Power Connection		Electrostatic History	14
Status Light		Frequently Asked Questions.	16
Line Level (RCA) Connection		Troubleshooting	18
Speaker Level Connection	8	General Information	19
Acoustic Contour Switch		Specifications	
Break-In		Warranty and Registration	
Installation.	9	Serial Number	
Installation Options		Service	
Using the Non-Skid Grip Feet		Dimensional Drawings	20
Mounting the Feature on a Wall		On Non-Skid Grip Feet	
Home Theater	11	With Bracket	21
Electrostatic Advantages	12	Glossary of Audio Terms	22



In accordance with the European Union WEEE (Waste Electrical and Electronic Equipment) directive effective August 13, 2005, we would like to notify you that this product may contain regulated materials which upon disposal, according to the WEEE directive, require special reuse and recycling processing.

For this reason MartinLogan has arranged with our distributors in European Union member nations to collect and recycle this product at no cost to you. To find your local distributor please contact the dealer from whom you purchased this product, email info@martinlogan.com or visit the distributor locator at www.martinlogan.com.

Please note, only this product itself falls under the WEEE directive. When disposing of packaging and other related shipping materials we encourage you to recycle these items through the normal channels.



The lightning bolt flash with arrowhead symbol, within an equilateral triangle, is intended to alert the user to the presence of potentially "dangerous voltage" within the product's enclosure that may be sufficient to constitute a risk of electric shock.



The exclamation point within an equilateral triangle is intended to alert the user to the presence of important operating and maintenance (servicing) instructions in the literature accompanying the appliance.



WARNING! Do not use your Feature loudspeaker outside of the country of original sale—voltage requirements vary by country. Improper voltage can cause damage that will be potentially expensive to repair. The Feature is shipped to authorized MartinLogan distributors with the correct power supply for use in the country of intended sale. A list of authorized distributors can be accessed at www.martinlogan.com or by emailing info@martinlogan.com.

INSTALLATION IN BRIEF

We know you are eager to hear your new MartinLogan loudspeaker, so this section is provided to allow fast and easy set up. Once your new speaker is operational, please take the time to read, in depth, the rest of the information in the enclosed manual. It will give you perspective on how to attain the greatest possible performance from this most exacting transducer.

If you experience any difficulties in the setup or operation of your MartinLogan speaker, please refer to the Connections section of the user's manual.

Should you encounter a persistent problem that cannot be resolved, please contact your authorized MartinLogan dealer. They will provide you with the appropriate technical analysis to alleviate the situation.



WARNING!

- Hazardous voltages exist inside—do not remove cover.
- Refer servicing to a qualified technician.
- To prevent fire or shock hazard, do not expose this module to moisture.
- Turn amplifier off and unplug speaker should any abnormal conditions occur.
- Turn amplifier off before making or breaking any signal connections!
- Do not operate if there is any visual damage to the electrostatic panel element.
- Do not drive speaker beyond its rated power.
- The power cord should not be installed, removed, or left detached from the speaker while the other end is connected to an AC power source.
- No candles or other sources of open flame should be placed on the speaker.
- No liquids either in glasses or vases should be placed on speaker.
- Speaker should not be exposed to dripping or splashing liquids.
- The terminals marked with the lightning bolt symbol should be connected by an instructed person or by way of ready made terminals.
- To prevent injury, this apparatus must be securely attached to the floor/wall in accordance with the installation instructions.

Step 1: Unpacking

Following the instructions printed on the product carton, remove your new MartinLogan speaker from its packaging. Retain the packaging in a safe, dry place for future use.

Step 2: Placement

Place the speaker at the desired location. Please see the Installation section (pages 9–10) for more details.

Step 3: Power Connection (AC) (see warning)

Your Feature speaker requires power to energize its electrostatic panel and internal amplifier. Using the power cords provided, plug first to the power in receptacle on the rear panel of the speaker, making sure that you have made a firm connection, and then to the wall outlet. Please see the Connections section (page 7) for more details.

Step 4: Signal Connection

Attach your speaker using either the Line Level input or the Speaker Level input on the rear panel of your speaker.

High quality cables, available from your specialty dealer, are recommended and will give you superior performance. Use the best cable(s) you can.

When using the Speaker Level inputs be consistent when connecting speaker leads to the terminals on the back of the Feature speakers. Take great care to assign the same color to the (+) terminal on both the left, right, and center channels. If bass is weak and you cannot discern a tight, coherent image, you may need to reverse the (+) and (-) leads on one side to bring the system into proper polarity. Spade connectors are suggested for optimum contact and ease of installation.

For detailed setup instructions, please turn to the Connections section (Page 7) of this manual for more details.

Step 5: Listen and Enjoy

Now, you may turn on your system and enjoy!

INTRODUCTION

Congratulations! You have invested in one of the world's premier loudspeaker systems.

Internally powered with a high-resolution digital amplifier, the Feature provides an unprecedented level of system connection flexibility. Equipped with a standard line-level input, the Feature is able to connect directly to devices such as digital music players, flat screen televisions, or even computers. Additional speaker level inputs also allow Feature to perform in a more traditional receiver or pre-amp equipped 2-channel or home theater system.

Feature's CLS transducer builds upon the legacy of MartinLogan's electrostatic heritage with the incorporation of advanced vacuum bonding and MicroPerf stat panels, providing even greater efficiency and precision. The integration electrical interface technology developed by MartinLogan's Statement™ e2 engineering team extends effortless dynamics and purity, resulting in even higher sonic standards of efficiency and precision.

Through rigorous testing, MartinLogan's curvilinear electrostatic panel has proven itself to be one of the most durable and reliable transducers available today. Fabricated from a custom tool punched high-grade steel, the patented stator is then coated with a special polymer that is applied

via a proprietary electrostatic bonding process. This panel assembly houses a membrane just 0.0005 of an inch thick. Ruggedly constructed and insulated, the panel is rated to easily handle up to 150 watts of continuous power with no deleterious effects.

Featuring an advanced crossover topology derived from engineering established with the Summit loudspeaker, MartinLogan engineered the Feature™ crossover using precision audiophile-grade polypropylene capacitors and high-purity air-core coils. This advanced crossover topology flawlessly preserves sonic subtleties while effortlessly handling the broadest range of dynamics.

The materials in your new Feature speaker are of the highest quality and will provide years of enduring enjoyment with deepening respect. The cabinetry is constructed from dense composite material for acoustical integrity.

The other sections of your User's Manual explain in detail the operation of your Feature speaker and the philosophy applied to its design. A clear understanding of your speaker will insure that you obtain maximum performance and pleasure from this most exacting transducer. It has been designed and constructed to give you years of trouble-free listening enjoyment.

CONNECTIONS AND CONTROLS

AC Power Connection

Because your Feature speaker uses an internal power supply to energize its electrostatic panel and to power the internal amplifier, it must be connected to an AC power source. For this reason it is provided with the proper IEC standard power cords. These cords should be firmly inserted into the AC power receptacles on the rear connection panel of the speaker, then to any convenient AC wall outlet (see figure 2 & 3). The Feature integrates a signal sensing power supply which will switch off after five minutes of no music signal, and requires less than two seconds to recharge the panels when a music signal is present.

Your Feature speaker is wired for the power service supplied in the country of original consumer sale. The AC power requirements applicable to a particular unit is specified both on the packing carton and on the serial number plate attached to the speaker. If you remove your Feature speakers from the country of original sale, be certain that the AC power supplied in any subsequent location is suitable before connecting and operating the speaker. Substantially impaired performance or severe damage may occur to an Feature speaker if operation is attempted from an incorrect AC power source.

 **WARNING!** The power cord should not be installed, removed, or left detached from the speaker while the other end is connected to an AC power source.

Status Light

On the rear connection panel is a status light. This light indicates the following operation modes:

- **Blue:** The speaker is active and ready to play.
- **Red:** The speaker is in auto standby mode.
- **Flashing Red:** The speaker is in auto-protect mode. This may occur if the internal amplifier overheats. To reset the speaker unplug it for 10 seconds. *This also occurs if the speaker is being used with an incompatible AC voltage (i.e. outside country of original sale).*

Line Level (RCA) Connection

When using the Line Level connection do not use the Speaker Level connections at the same time.

For optimal performance, MartinLogan recommends line level (RCA) connection.

Use Feature's line level connection to attach any of the following devices (see figure 1):

- Television or computer
- Digital Music Player or docking station
- Receiver / Pre-Amp (using pre-amp outputs)

Connection is achieved by connecting an RCA cable from the output on the device to the Line Level input on the Feature. If your output device is not equipped with an RCA style output connector we recommend using a 3.5mm stereo headphone to dual RCA connector (available at nearly any electronics retailer).

When using Feature's Line Level Input, make sure that the output device's connection utilizes a variable level control

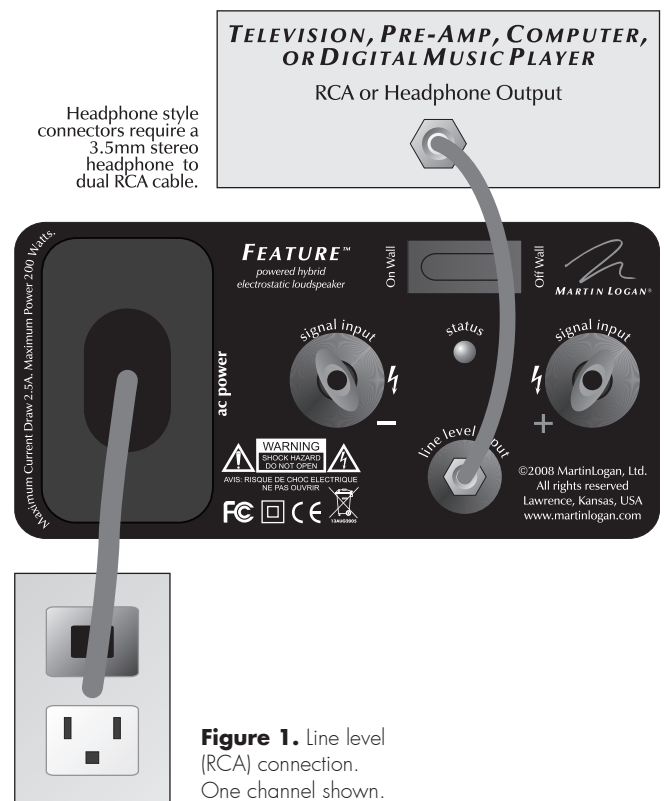

(i.e. volume control). Usually this is a headphone or pre-amp output. However, as this varies from device to device we recommend referencing your device's user manual.

Please note: When making or breaking connections from devices that utilize the Line Level input a popping noise may occur. This is caused by grounding and static discharge interaction. It is normal and to be expected when using this method of connection. If a cable is connected to the speaker, but is left unterminated at the device end you may also experience a low-level hum. To minimize these intermittent noises we recommend using a device that is permanently connected (such as a digital music player docking station).

Speaker Level Connection

When using the Speaker Level connections do not use the Line Level connection at the same time.

Use spade connectors for optimum contact and ease of installation. Hand tighten the binding posts, but do not

overtighten—do not use a tool to tighten the binding posts (see figure 2).

Be consistent when connecting the speaker cables to the signal input terminals. Take care to assign the same color cable lead to the (+) terminal on both the left, right, and center channel speakers. If bass is nonexistent and you cannot discern a tight, coherent image, you may need to reverse the (+) and (–) leads on one speaker to bring the system into proper polarity.

Please note: When using the speaker level inputs a popping noise may occur when the amplifier is turned on or off. This is caused by grounding interaction between the speaker and the amplifier. It is normal and to be expected. The Feature utilizes a muting circuit that will detect such anomalies and minimize them.



WARNING! Turn your amplifier off before making or breaking any signal connections!

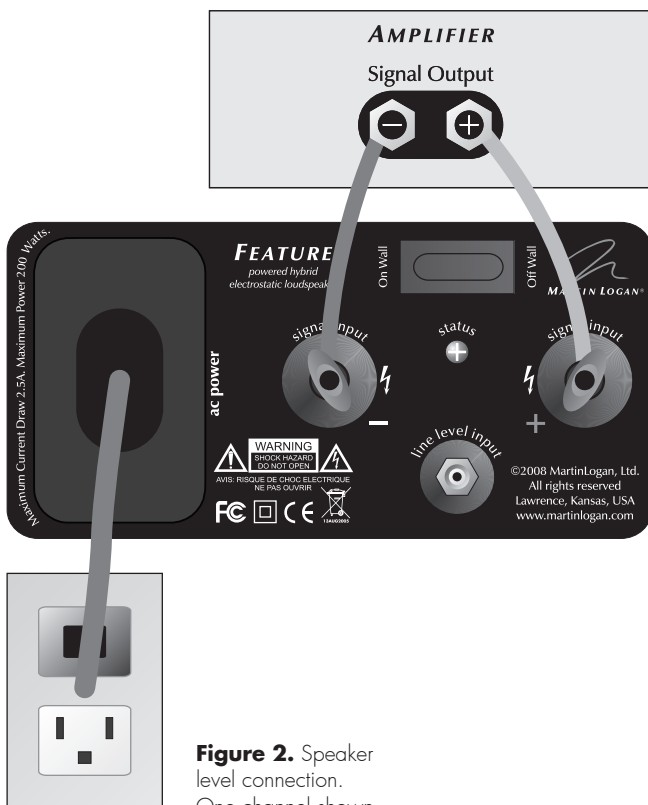

Figure 2. Speaker level connection. One channel shown.

Acoustic Contour Switch

Feature employs a unique 'on-wall/off-wall' switch that tailors acoustic equalization to either installation option. Simply set this switch to On-Wall if mounting to a surface. Set the switch to Off-Wall if the Feature is more than four inches from a wall. Setting this switch ensures that you will achieve total system matching in even the most diverse setups (such as systems mixing on-wall and off-wall installations).

Break-In

Break-in will improve bass extension. Our custom made, butyl surround woofer requires approximately 72 hours of break-in at 90 dB (moderate listening levels) before any critical listening. When you begin to play your speakers, they will sound a bit bass shy due to the high quality, long-life components used in our woofers. The break-in requirements of the crossover components and the electrostatic stator are equivalent.

Installation Options

On the Television or Stand

If your television provides a wide, level and stable platform, the Feature can be placed directly on top of the television (see figure 3). The Feature may also be placed on an equipment stand. When used this way, the non-skid rubber grip feet should be used beneath the Feature to provide stability.

On the Floor

Placing the Feature on the floor might position it too low to blend with the front speakers. If placing the Feature on the floor is your best option, the adjustable stand (sold separately—MartinLogan part number 9870002) will allow you to tilt the Feature towards the listening position.

On the Wall

The included brackets allow you to mount the Feature on the wall (see figures 4 and "Mounting the Feature On A Wall," page 10).



WARNING! Installation other than that described in the body of this document requires specific documentation from MartinLogan.

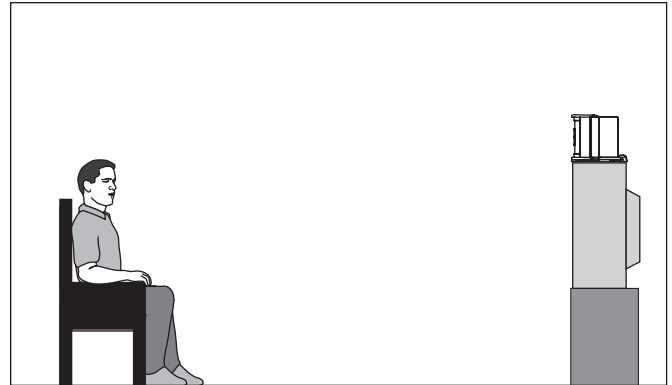

Figure 3. Feature installation on a television.

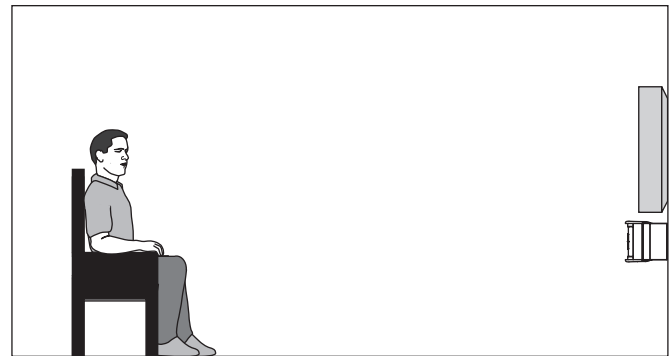

Figure 4. Feature installation on a wall.

Using the Non-Skid Grip Feet

When setting Feature on a surface, use the non-skid Grip Feet beneath the speaker to provide traction (see figure 5).

Mounting the Feature On A Wall

NOTE: These instructions assume the mounting surface is of wood frame and standard sheet rock construction. If you wish to mount the Feature to another type of material or construction, you should consult a bonded contractor.

NOTE: Before beginning, study the Horizontal and Vertical Hardware Configuration drawings (figures 6 & 7).

IMPORTANT! This template is used for both horizontal and vertical installations. When drilling pilot holes and tracing keyholes make sure you're using the 2 pilot hole and 2 keyhole locations intended for your installation.

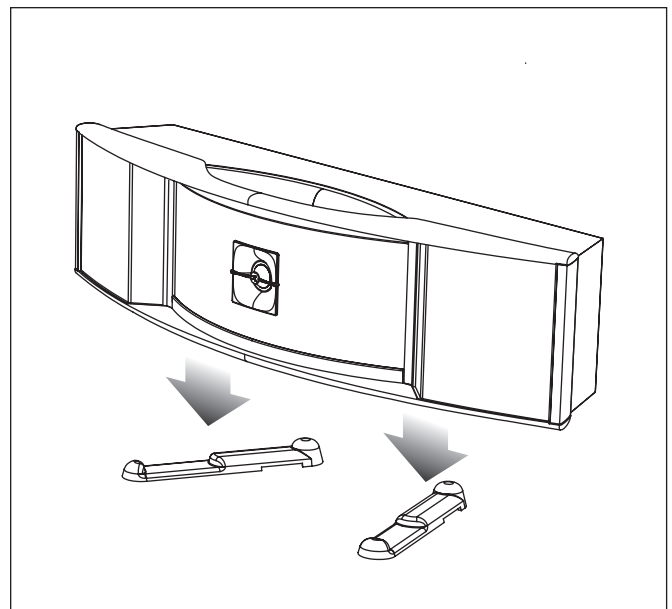
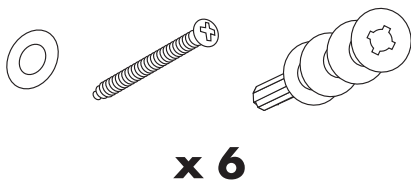
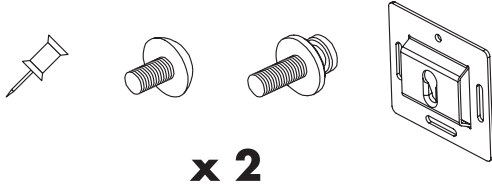
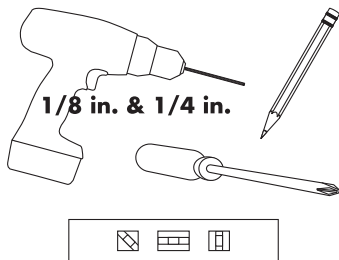

Figure 5. If Feature is to be used with the optional adjustable stand, place the non-skid grip feet on the stand and beneath the speaker.

Required hardware (included):



Required tools (not supplied):



- 1 Position the template. Install the center push pin.
- 2 Level the template. Install the second push pin.
- 3 Using a pencil trace two keyholes located on the template.
- 4 Using a 1/8-inch drill bit, drill two pilot holes located on the template.
- 5 Remove the template.
- 6 If a pilot hole does not hit a stud use a 1/4-inch drill bit to widen the hole and install a wall anchor.
- 7 Install both wall brackets using only the top screw. Do not over tighten the top screw.
- 8 Align each wall bracket's keyhole with a traced keyhole and tighten the top screw.
- 9 On the back of the Feature, install two shoulder bolts

in the top holes and two rubber bumpers in the bottom holes. Test fit the speaker. Adjust the bracket positions until the speaker fits. **IMPORTANT!** At this point do not allow the speaker to hang freely—there are not enough screws installed to fully support its weight.

- 10 Drill two more pilot holes (per bracket) at the screw hole locations on the left & right sides of both wall brackets.
- 11 If a pilot hole does not hit a stud remove the wall bracket, use a 1/4-inch drill bit to widen the hole, and install a wall anchor.
- 12 Install both wall brackets using all 3 screws per bracket. Tighten the screws.
- 13 Hang the speaker on the wall brackets.

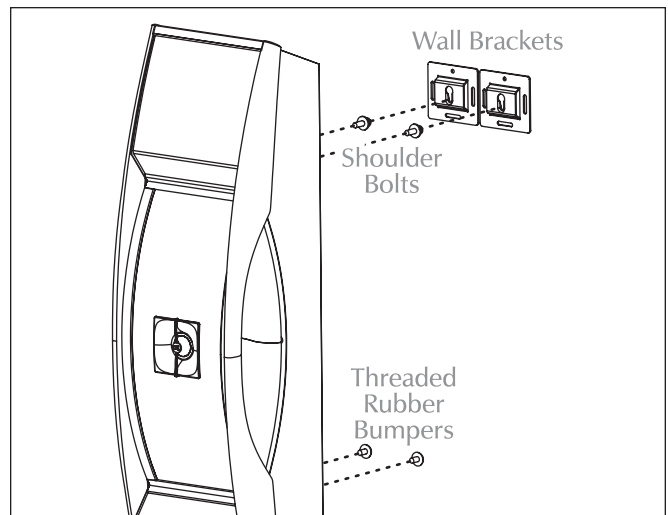

Figure 6. Vertical Hardware Configuration

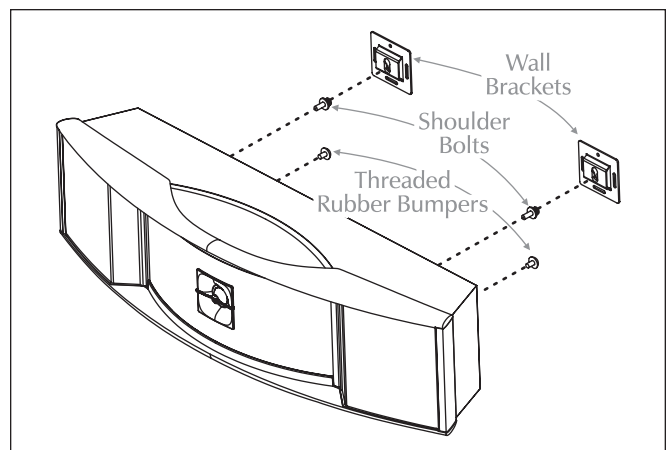

Figure 7. Horizontal Hardware Configuration

It had long been the practice of stereo buffs to connect their television to a stereo system. The advantage was the use of the larger speakers and more powerful amplifier of the stereo system. Even though the sound was greatly improved, it was still mono and limited by the broadcast signal.

In the late 1970's and early 1980's two new home movie formats became widely available to the public: VCR and laser disc.

By 1985, both formats had developed into very high quality audio/video sources. In fact, the sonic performance of some video formats exceeded audio-only formats. Now, with theater-quality sound available at home, the only element missing was the "surround sound" presentation found in movie houses.

Fortunately, Dolby and DTS encoded DVD's emerged with the same surround sound information encoded on home releases as the theatrical release. Additionally, new high-resolution home-viewing formats such as Blu-ray as well as high-definition content provided via cable or satellite have evolved which include multi-channel encoded audio that is virtually master tape quality. All that is required to retrieve this information is a decoder and additional speakers and amps to reproduce it.

Home theater is a complex purchase and we recommend that you consult your local MartinLogan dealer, as they are well versed in this subject.

Each piece of a surround system can be purchased separately. Take your time and buy quality. No one has ever complained that the movie was too real. The following list and descriptions will give you only a brief outline of the responsibilities and demands placed on each speaker.

Front Left and Front Right

If these speakers will be the same two used for your stereo playback, they should be of very high quality and able to play loudly (over 102 dB) and reproduce bass below 80 Hz.

Center Channel

This is the most important speaker in a home theater system, as almost all of the dialogue and a large portion of the front speaker information is reproduced by the center channel. It is important that the center speaker be extremely accurate and mate well with the front speaker,

and that it is recommended for use as a center speaker. This is not the place to cut corners.

Surround Speakers

We recommend (along with the film industry) that the surround speakers play down to at least 80 Hz. Surround speakers contain the information that makes it appear that planes are flying over your head. Some may suggest that this is the place to save money and purchase small, inexpensive speakers. If you choose to do so, be prepared to upgrade in the future as discrete multi-channel digital encoding is proliferating rapidly and the demands on surround speakers have increased.

Subwoofer

With any good surround system you will need one or more high-quality subwoofers (the .1 in a 5.1, 6.1, or 7.1 channel surround system). Most movie soundtracks contain large amounts of bass information as part of the special effects. Good subwoofers will provide a foundation for the rest of the system.

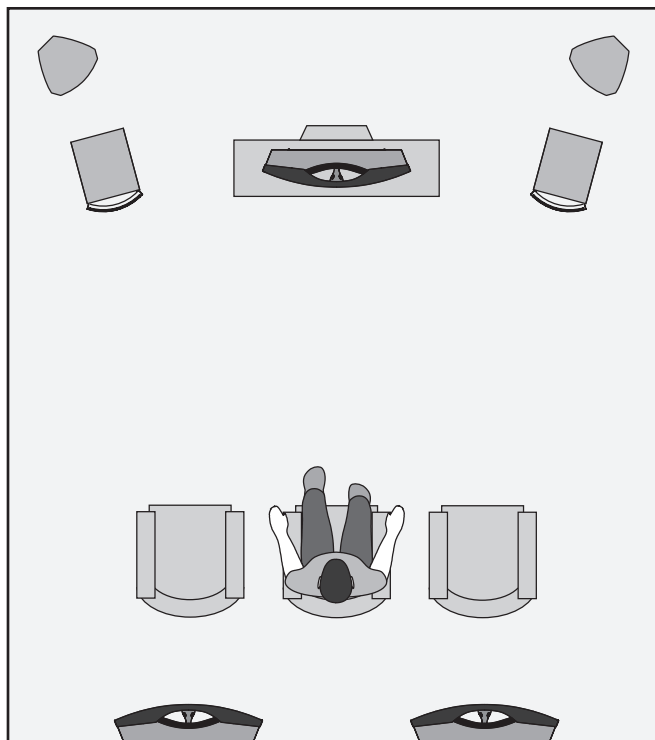

Figure 8. Purity speakers as front channels, the Feature as the center and surround channels, and the Grotto i subwoofers as 0.1 (effects) chan-

ELECTROSTATIC ADVANTAGES

How can sound be reproduced by something that you are able to see through? Electrostatic energy makes this possible.

Where the world of traditional loudspeaker technology deals with cones, domes, diaphragms and ribbons that are moved with magnetism, the world of electrostatic loudspeaker deals with charged electrons attracting and repelling each other.

To fully understand the electrostatic concept, some background information will be helpful. Remember when you learned in a science or physics class that like charges repel each other and opposite charges attract each other? Well, this principle is the foundation of the electrostatic concept.

An electrostatic transducer consists of three pieces: stators, the diaphragm and spacers (see figure 9). The diaphragm is what actually moves to excite the air and create music. The stator's job is to remain stationary, hence the word stator, and to provide a reference point for the moving diaphragm. The spacers provide the diaphragm with a fixed distance in which to move between the stators.

As your amplifier sends music signals to an electrostatic speaker, these signals are changed into two high-voltage signals that are equal in strength but opposite in polarity. These high voltage signals are then applied to the stators. The resulting electrostatic field, created by the opposing high voltage on the stators, works simultaneously with and against the diaphragm, consequently moving it back and forth, producing music. This technique is known as

push-pull operation and is a major contributor to the sonic purity of the electrostatic concept due to its exceptional linearity and low distortion.

Since the diaphragm of an electrostatic speaker is uniformly driven over its entire area, it can be extremely light and flexible. This allows it to be very responsive to transients, thus perfectly tracing the music signal. As a result, great delicacy, nuance and clarity is possible. When you look at the problems of traditional electromagnetic drivers, you can easily see why this is so beneficial. The cones and domes which are used in traditional electromagnetic drivers cannot be driven uniformly because of their design. Cones are driven only at the apex. Domes are driven at their perimeter. As a result, the rest of the cone or dome is just "along for the ride". The very concept of these drivers requires that the cone or dome be perfectly rigid, damped and massless. Unfortunately, these conditions are not available in our world today.

To make these cones and domes move, all electromagnetic drivers must use voice coils wound on formers, spider assemblies, and surrounds to keep the cone or dome in position (see figure 10). These pieces, when combined with the high mass of the cone or dome materials used, make it an extremely complex unit with many weaknesses and potential for failure. These faults contribute to the high distortion products found in these drivers and is a tremendous disadvantage when you are trying to change motion as quickly and as accurately as a loudspeaker must (40,000 times per second!).

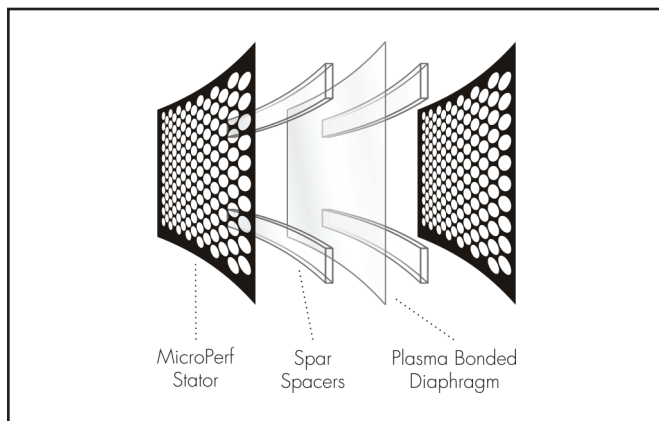

Figure 9. Cut away view of an electrostatic transducer. Notice the simplicity due to minimal parts usage.

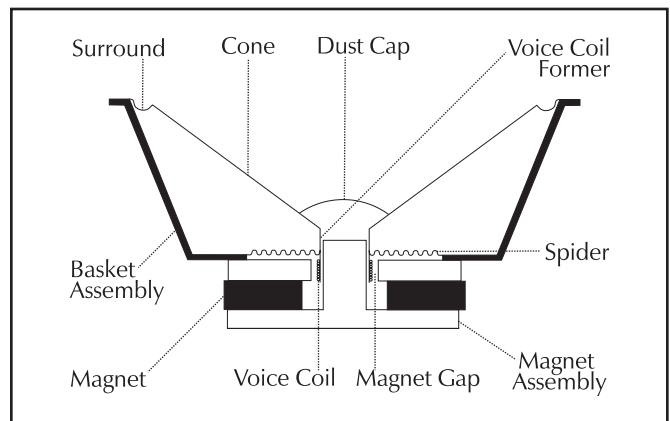

Figure 10. Cut away view of a typical moving coil driver. Notice the complexity due to the high number of parts.

CLS™ (Curvilinear Line Source)

Since the beginning of audio, achieving smooth dispersion has been a problem for all designers. Large panel transducers present unique challenge because the larger the panel, the more directional the dispersion pattern becomes.

Wide range electrostats have long been one of the most problematic transducers because they attain their full range capabilities via a large surface area. It looked as if they were in direct conflict to smooth dispersion and almost every attempt to correct this resulted in either poor dispersion or a serious compromise in sound quality.

After extensive research, MartinLogan engineers discovered an elegantly simple solution to achieve a smooth pattern of dispersion without degrading sound quality. By curving the horizontal plane of the electrostatic transducer, a controlled horizontal dispersion pattern could be achieved, yet the purity of the almost massless electrostatic diaphragm remained uncompromised. After creating this technology, MartinLogan developed the production capability to bring it out of the laboratory and into the market place. You will find this proprietary MartinLogan technology used in all of our electrostatic products. It is one of the many reasons behind our reputation for high quality sound with practical usability. This is also why you see the unique “see through” cylindrical shape of MartinLogan products.

Generation 2 Diaphragm

Feature’s diaphragm employs an extremely sophisticated conductive coating applied to the polymer surface at an atomic level using a plasma bonding process. A proprietary compound is driven into the surface of the polymer film in an oxygen free argon chamber. This process allows extremely uniform surface resistivity characteristics, an optically transparent surface, and a nearly massless diaphragm. This uniform surface resistivity controls the electrostatic charge on the diaphragm surface and regulates its migration. As a result, no discharging or “arcing” can occur.

MicroPerf Stator

Sleek. Compact. MicroPerf stator technology reveals more open playable area in each panel, offering increased performance from even more compact stat panels. It is significant to note that electrostatic transducer in the radical new Feature loudspeaker supports the bandwidth and dynamics associated with traditional electrostatic panels nearly twice its size.

ELECTROSTATIC HISTORY

In the late 1800's, any loudspeaker was considered exotic. Today, most of us take the wonders of sound reproduction for granted.

It was 1880 before Thomas Edison had invented the first phonograph. This was a horn-loaded diaphragm that was excited by a playback stylus. In 1898, Sir Oliver Lodge invented a cone loudspeaker, which he referred to as a "bellowing telephone", that was very similar to the conventional cone loudspeaker drivers that we know today. However, Lodge had no intention for his device to reproduce music because in 1898 there was no way to amplify an electrical signal! As a result, his speaker had nothing to offer over the acoustical gramophones of the period. It was not until 1906 that Dr. Lee DeForrest invented the triode vacuum tube. Before this, an electrical signal could not be amplified. The loudspeaker, as we know it today, should have ensued then, but it did not. Amazingly, it was almost twenty years before this would occur.

In 1921, the electrically cut phonograph record became a reality. This method of recording was far superior to the mechanically cut record and possessed almost 30 dB of dynamic range. The acoustical gramophone couldn't begin to reproduce all of the information on this new disc. As a result, further developments in loudspeakers were needed to cope with this amazing new recording medium.

By 1923, Bell Telephone Laboratories made the decision to develop a complete musical playback system consisting of an electronic phonograph and a loudspeaker to take advantage of the new recording medium. Bell Labs assigned the project to two young engineers, C. W. Rice and E. W. Kellogg.

Rice and Kellogg had a well equipped laboratory at their disposal. This lab possessed a vacuum tube amplifier with an unheard of 200 watts, a large selection of the new electrically cut phonograph records and a variety of loudspeaker prototypes that Bell Labs had been collecting over the past decade. Among these were Lodge's cone, a speaker that used compressed air, a corona discharge (plasma) speaker, and an electrostatic speaker.

After a short time, Rice and Kellogg had narrowed the field of "contestants" down to the cone and the electrostat. The outcome would dictate the way that future generations would refer to loudspeaker as being either "conventional" or "exotic".

Bell Laboratory's electrostat was something to behold. This enormous bipolar speaker was as big as a door. The diaphragm, which was beginning to rot, was made of a pig intestine that was covered with fine gold leaf to conduct the audio signal.

When Rice and Kellogg began playing the new electrically cut records through the electrostat, they were stunned and impressed. The electrostat performed splendidly. They had never heard instrumental timbres reproduced with such realism. This system sounded like real music rather than the honking, squawking rendition of the acoustic gramophone. Immediately, they knew they were on to something big.

The acoustic gramophone was destined to become obsolete.

Due to Rice and Kellogg's enthusiasm, they devoted a considerable amount of time researching the electrostatic design. However, they soon encountered the same difficulties that even present designers face; planar speakers require a very large surface area to reproduce the lower frequencies of the audio spectrum. Because the management at Bell Labs considered large speakers unacceptable, Rice and Kellogg's work on electrostatics would never be put to use for a commercial product. Reluctantly, they advised the Bell management to go with the cone. For the next 30 years, the electrostatic design lay dormant.

During the Great Depression of the 1930's, consumer audio almost died. The new electrically amplified loudspeaker never gained acceptance, as most people continued to use their old Victrola-style acoustic gramophones. Prior to the end of World War II, consumer audio saw little, if any, progress. However, during the late 1940's, audio experienced a great rebirth. Suddenly there was tremendous interest in audio products, and with that, a great demand for improved audio components. No sooner had the cone become established than it was challenged by products developed during this new rebirth.

Rice and Kellogg had narrowed the field of "contestants down" to the cone and the electrostat.

In 1947, Arthur Janszen, a young Naval engineer, took part in a research project for the Navy. The Navy was interested in developing a better instrument for testing microphone arrays. The test instrument needed an extremely accurate speaker, but Janszen found that the cone speaker of the period were too nonlinear in phase and amplitude response to meet his criteria. Janszen believed that electrostats were inherently more linear than cones, so he built a model using a thin plastic diaphragm treated with a conductive coating. This model confirmed Janszen's beliefs, for it exhibited remarkable phase and amplitude linearity.

Janszen was so excited with the results that he continued research on the electrostatic speaker on his own time. He soon thought of insulating the stators to prevent the destructive effects of arcing. By 1952, he had an electrostatic tweeter element ready for commercial production. This new tweeter soon created a sensation among American audio hobbyists. Since Janszen's tweeter element was limited to high frequency reproduction, it often found itself used in conjunction with woofers—most notably, those from Acoustic Research. These systems were highly regarded by all audio enthusiasts.

As good as these systems were, they would soon be surpassed by another electrostatic speaker.

In 1955, Peter Walker published three articles regarding electrostatic loudspeaker design in *Wireless World*, a British magazine. In these articles, Walker demonstrated the benefits of the electrostatic loudspeaker. He explained that electrostatics permit the use of diaphragms that are low in mass, large in area and uniformly driven over their surfaces by electrostatic forces. Due to these characteristics, electrostats have the inherent ability to produce a wide bandwidth, flat frequency response with distortion products being no greater than the electronics driving them.

By 1956, Walker backed up his articles by introducing a consumer product, the now famous Quad ESL. This speaker immediately set a standard of performance for the audio industry due to its incredible accuracy. However, in actual use, the Quad had a few problems. It could not be played very loud, it had poor bass performance, it presented a difficult load that some amplifiers did not like,

its dispersion was very directional and its power handling was limited to around 70 watts. As a result, many people continued to use box speakers with cones.

In the early 1960's Arthur Janszen joined forces with the KLH loudspeaker company, and together they introduced the KLH 9. Due to the large size of the KLH 9, it did not have as many sonic limitations as the Quad. The KLH 9 could play markedly louder and lower in frequency than the Quad ESL. Thus a rivalry was born.

Janszen continued to develop electrostatic designs. He was instrumental in the design of the Koss Model One, the Acoustech and the Dennesen speaker. Roger West, the chief designer of the Janszen Corporation, became the president of Sound Lab. When Janszen Corporation was sold, the RTR loudspeaker company bought half of the production tooling. This tooling was used to make the electrostatic panels for the Servostatic, a hybrid electrostatic system that was Infinity's first speaker product. Other companies soon followed; each with their own unique applications of the technology. These include Acostat, Audiostatic, Beveridge, Dayton Wright, Sound Lab and Stax, to name a few.

Electrostatic speakers have progressed and prospered because they actually do what Peter Walker claimed they would. The limitations and problems experienced in the past were not inherent to the electrostatic concept. They were related to the applications of these concepts.

Today, these limitations have been resolved. Advancements in materials due to the U.S. space program give designers the ability to harness the superiority of the electrostatic principle. Today's electrostats use advanced insulation techniques or provide protection circuitry. The poor dispersion properties of early models have been addressed by using delay lines, acoustical lenses, multiple panel arrays or, as in our own products, by curving the diaphragm. Power handling and sensitivity have also been increased.

These developments allow the consumer the opportunity to own the highest performance loudspeaker products ever built. It's too bad Rice and Kellogg were never able to see just how far the technology would be taken.

**These developments allow
the consumer to own the
highest performance loud-
speaker products ever built.**

FREQUENTLY ASKED QUESTIONS

How do I clean my speaker?

Use a dust free cloth or a soft brush to remove the dust from your speaker. We also recommend a specialty cloth (available at the Xstatic shop at www.martinlogan.com) that cleans your speaker better than anything else we have tried. For the wood surfaces it is acceptable to slightly dampen the cloth. **Do not spray any kind of cleaning agent on or in close proximity to the electrostatic element. Avoid the use of ammonia based products or silicone oil on the wood parts.**

What is the advantage of ESL?

Since the diaphragm is uniformly driven over its entire surface—unlike a tweeter that is only driven at its edges— it is the only technology that can be made large enough to play bass, yet is still light enough for high frequencies. This unique property allows for the elimination of high frequency crossover points and their associated distortions.

What size amplifier should I use?

We recommend an amplifier with 100 to 250 watts per channel for most applications. Probably less would be adequate for our smaller hybrids or when used in home theater where a subwoofer is employed. Our hybrid designs will perform well with either a tube or transistorized amplifier, and will reveal the sonic character of either type. However, it is important that the amplifier be stable operating into varying impedance loads: an ideally stable amplifier will typically be able to deliver nearly twice its rated wattage into 4 Ohms and should again increase into 2 Ohms.

Could you suggest a list of suitable electronics and cables that would be ideal for MartinLogan speakers?

The area of electronics and cable choice is probably the most common type of question that we receive. It is also the most subjective. We have repeatedly found that brands that work well in one setup will drive someone else nuts in another. We use many brands with great success. Again, we have no favorites; we use electronics and cables quite interchangeably. We would suggest listening to a number of brands—and above all else— trust your ears. Dealers are always the best source for information when purchasing additional audio equipment.

Is there likely to be any interaction between my speaker and the television in my Audio/Video system?

Actually, there is less interaction between a television and an electrostatic speaker than between a television and a conventional system. However, we generally recommend that you keep your speaker at least one foot away from the television because of the dynamic woofer they employ. In the case of the Feature, however, they are fully shielded and can go anywhere.

Will my electric bill go 'sky high' by leaving my speaker plugged in all the time?

No. A pair of MartinLogan's will draw about 8 watts maximum (idle). There is circuitry to turn off the static charge when not in use; however, actual consumption will remain close to the same. The primary purpose of the sensing circuitry is to prevent dust collection on the electrostatic element.

If the diaphragm is punctured with a pencil or similar item, how extensive would the damage to the speaker be?

Our research department has literally punctured hundreds of holes in a diaphragm, neither affecting the quality of the sound nor causing the diaphragm to rip. However, you will be able to see the actual puncture and it can be a physical nuisance. If this is the case, replacing the electrostatic transducer will be the only solution.

Will exposure to sunlight affect the life or performance of my speaker?

We recommend that you not place any loudspeaker in direct sunlight. The ultraviolet (UV) rays from the sun can cause deterioration of grill cloth, speaker cones, etc. Small exposures to UV will not cause a problem. In general, the filtering of UV rays through glass will greatly reduce the negative effects on the electrostatic membrane itself.

Will excessive smoke or dust cause any problems with my electrostatic speakers?

Exposure to excessive contaminants such as smoke or dust may potentially affect the performance of the electrostatic membrane, and may cause discoloration of the diaphragm membrane. When not in use for extended periods, you should unplug the speakers and cover them with the plastic bags in which the speakers were originally packed. It is a good idea to vacuum the electrostatic portion of each speaker three or four times a year. See the vacuuming FAQ.

A problem has recently developed with my MartinLogan speakers. The right speaker seems to be hissing even when the amplifier and such are not connected. I was wondering if this sounds like any problem you have encountered previously and have a simple solution for or might it be something which will need to be looked into more carefully.

Your speakers are dusty. See the vacuuming FAQ. The electrostatic charge on the element has attracted airborne dust or pollen. Since 1993, all of our speakers have been built with a charging circuit board that only charges the electrostatic element when music plays. At other times they are not charged and cannot collect dust. You can get the same benefit by simply unplugging them whenever they are not in use. A power strip is an easy way to do that.

Could my children, pets, or myself be shocked by the high-voltage present in the electrostatic panel?

No. High voltage with low current is not dangerous. As a matter of fact, the voltage in our speakers is 10 times less than the static electricity that builds up on the surface of your television screen.

How do MartinLogan speakers hold up over a long term in the humidity of tropical climates?

We should tell you that MartinLogan indeed has a very substantial number of customers in tropical regions of the world. Our speakers have been serving them nicely for many years. This concern may have come from our earlier design of speakers, which were charged continuously. Since 1993, all of our speakers have been designed so that they only charge the panel while music is being played. This improvement has made a tremendous difference in the consistent performance of our product. There may be a little more maintenance involved in humid regions when not in an air conditioned environment. Simply enough, the concern is to keep the electrostatic panels dust free. Humidity will combine with any dust on the panel to make it slightly conductive. This will result in a slight pathway for the charge to leave the membrane of the speakers. The solution is simple. They only require occasional vacuuming with a strong vacuum hose.

How do I vacuum my MartinLogan speakers?

Vacuuming will be most effective if the speakers have been unplugged for six hours to twelve hours (or overnight). You need not worry about the vacuum pressure damaging the "delicate" membrane. It is extraordinarily durable. Dirt and dust may be vacuumed off with a brush attachment connected to your vacuum cleaner, or you may blow them off with compressed air. When vacuuming or blowing off your panels do so to both sides, but focus the majority of your attention on the front of the panels.

Should I unplug my speakers during a thunderstorm?

Yes, or before. It's a good idea to disconnect all of your audio/video components during stormy weather.

TROUBLESHOOTING

No Output

- Check that all your system components are turned on.
- Check your speaker wires and connections.
- Check all interconnecting cables.
- Try hooking up a different speaker. The lack of output could point to a problem with other equipment in your system (amp, pre-amp, processor, etc.)

Weak or no Output from Electrostatic Panel, Loss of Highs

- Check the power cord. Is it properly connected to the speaker and to the wall?
- Is the power cord connected to a switched outlet?
- Dirt and dust may need to be vacuumed off. Please see the FAQ regarding vacuuming.
- Check the binding posts. Are the dirty? If so clean them with rubbing alcohol.
- Check the binding posts. Are the loose? Make sure they are firmly hand-tightened.
- Has a foreign substance (such as a household cleaning chemical or soap) been applied to the panel? If so the speaker will require servicing.

Popping and Ticking Sounds, Funny Noises

- These occasional noises are harmless and will not hurt your audio system or your speaker. All electrostatic speakers are guilty of making odd noises at one time or another. It is the result of airborne contaminants (most notably dust). Vacuuming is recommended.
- These noises may be caused by dirt and dust particles collecting on the speaker, by high humidity.
- Dirt and dust may need to be vacuumed off. Please see the FAQ regarding vacuuming.

Muddy Bass

- Possibly means low electrostatic panel output. See 'Weak Output from Electrostatic Panel, Loss of Highs'.

Lack of Bass, No Bass

- Check your speaker wires. Is the polarity correct?
- Check the binding posts. Are the dirty? If so clean them with rubbing alcohol.
- Check the binding posts. Are the loose? Make sure they are firmly hand-tightened.

Poor Imaging

- Check the polarity of the speaker wires. Are they connected properly?
- Are your speakers set up in an L-shaped room? If so, you may experience off-center imaging. Talk to your dealer about acoustical room treatment options.

Specifications*

System Frequency Response

61–20,000 Hz \pm 3db

Dispersion: *Horizontal:* 30 Degrees

Sensitivity

93 dB/2.83 volts/meter (binding posts)

95 dB/0.1 volts/meter (line level input)

Impedance

2,000 Ohms (binding posts)

33,000 Ohms (line level input)

Crossover Frequency: 450Hz, 4000Hz

Components

Air core coils

Tweeter Type: 1" (2.5 cm) neodymium soft dome

Midrange Type: CLS™ Electrostatic

Woofer Type

Two 5.25" (13.4 cm) neodymium magnet, paper cone with extended throw driver assembly, non-resonant asymmetrical chamber format; shielded

Internal Amplifier: 150 watts

Power Handling: 150 watts

AC Mains Power Draw

Maximum Current Draw: 2.5 amps

Maximum Power: 200 watts

Standby Power: 8 watts

Weight: 21 lbs. each (9.5 kg)

Size (with feet)

7.6" h x 29.75" w x 9" d

(19.3 h x 75.6 w x 22.9 d cm)

Size (with wall bracket)

7.3" h x 29.75" w x 7.9" d

(18.6 h x 75.6 w x 20.1 d cm)

For detailed dimensional drawings, please see pages 20–21.

Warranty and Registration

Your Feature speaker is provided with an automatic Limited 90 Day Warranty coverage. You have the option, at no additional charge, to receive a Limited 5 Year Warranty coverage. To obtain the Limited 5 Year Warranty coverage you need to complete and return the Certificate of Registration, included with your speaker, and provide a copy of your dealer receipt, to MartinLogan within 30 days of purchase. For your convenience MartinLogan also offers online warranty registration at www.martinlogan.com.

MartinLogan may not honor warranty service claims unless we have a completed Warranty Registration card on file! If you did not receive a Certificate of Registration with your new Feature speaker you cannot be assured of having received new units. If this is the case, please contact your authorized MartinLogan dealer.

Serial Number

Feature's serial number is located directly beneath the binding posts.

Service

Should you be using your MartinLogan product in a country other than the one in which it was originally purchased, we ask that you note the following:

- 1 The appointed MartinLogan distributor for any given country is responsible for warranty servicing only on units distributed by or through it in that country in accordance with its applicable warranty.
- 2 Should a MartinLogan product require servicing in a country other than the one in which it was originally purchased, the end user may seek to have repairs performed by the nearest MartinLogan distributor, subject to that distributor's local servicing policies, but all cost of repairs (parts, labor, transportation) must be borne by the owner of the MartinLogan product.
- 3 If, after owning your speaker for six months, you relocate to a country other than the one in which you purchased your speaker, your warranty may be transferable. Contact MartinLogan for details.

**Specifications are subject to change without notice.*

DIMENSIONAL DRAWINGS

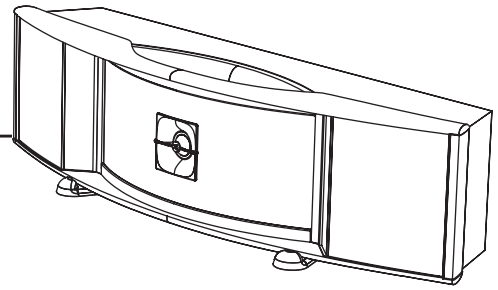

On Non-Skid Grip Feet

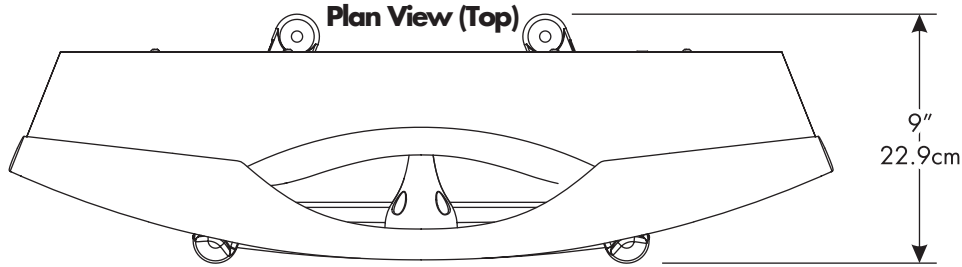

Front Elevation: (no stand rotation)

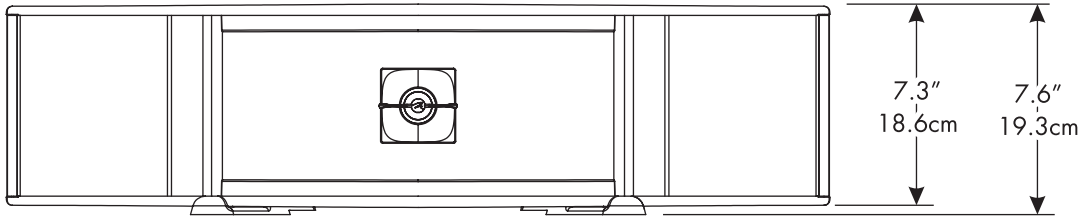

Back Elevation: (no stand rotation)

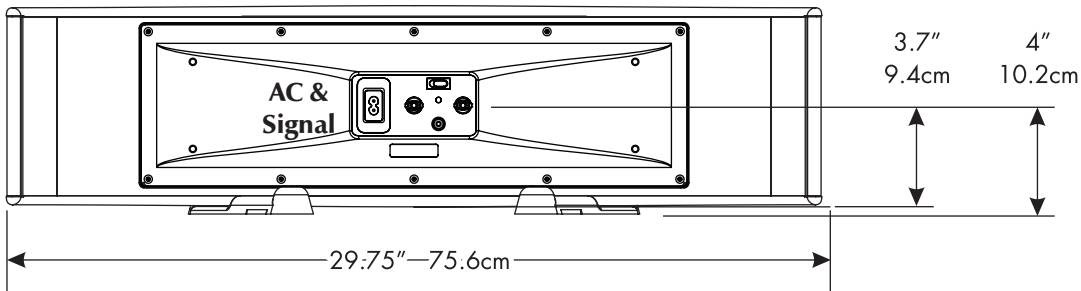

Side Elevation

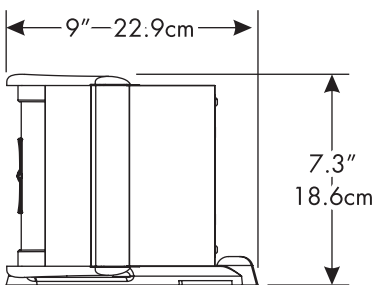

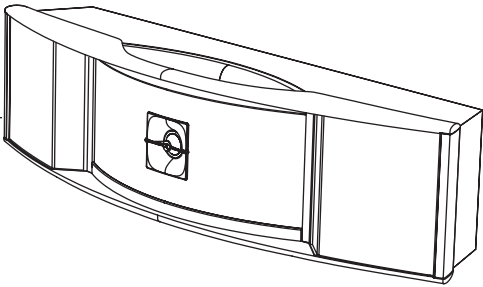

With Bracket

Plan View (Top)

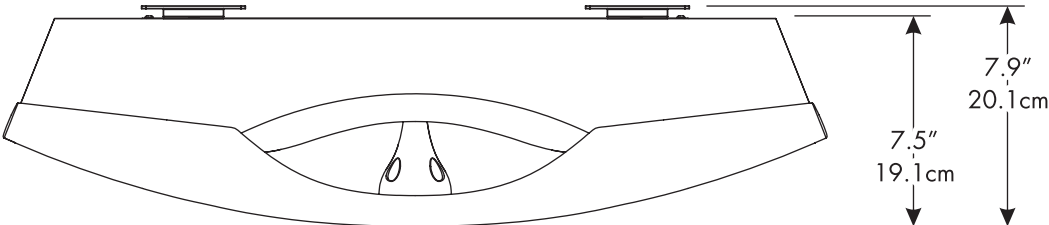

Front Elevation: (no stand rotation)

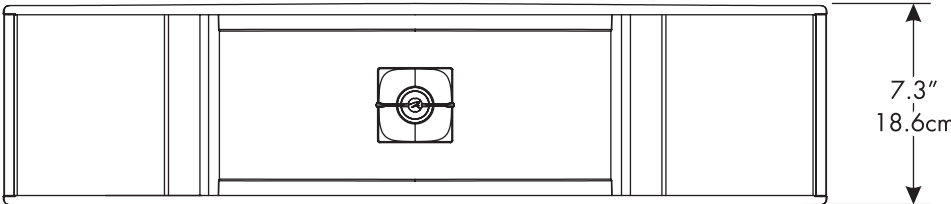

Back Elevation: (no stand rotation)

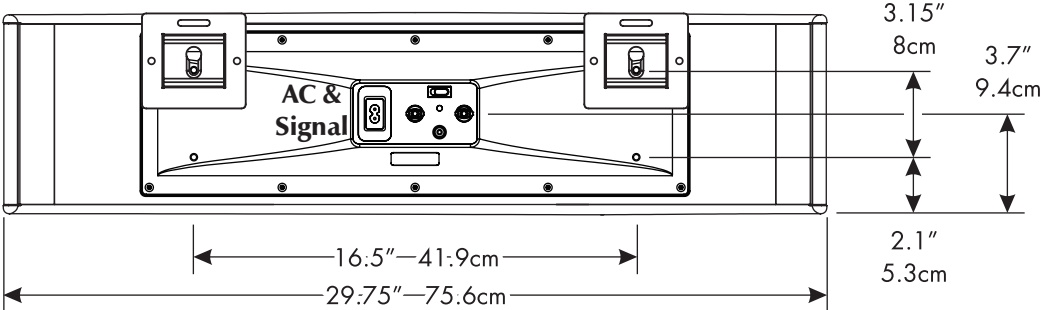

Side Elevation

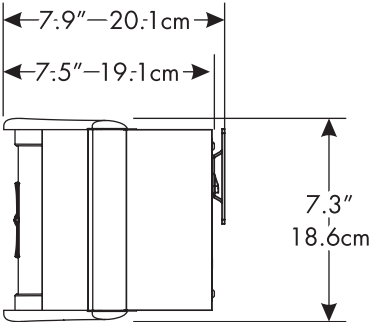

Wall Bracket

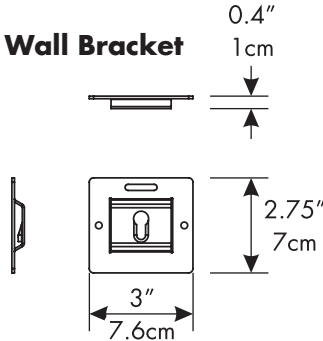

GLOSSARY OF AUDIO TERMS

AC. Abbreviation for alternating current.

Active crossover. Uses active devices (transistors, IC's, tubes) and some form of power supply to operate.

Amplitude. The extreme range of a signal. Usually measured from the average to the extreme.

Arc. The visible sparks generated by an electrical discharge.

Bass. The lowest frequencies of sound.

Bi-Amplification. Uses an electronic crossover, or line-level passive crossover, and separate power amplifiers for the high and low frequency loudspeaker drivers.

Capacitance. That property of a capacitor which determines how much charge can be stored in it for a given potential difference between its terminals, measured in farads, by the ratio of the charge stored to the potential difference.

Capacitor. A device consisting of two or more conducting plates separated from one another by an insulating material and used for storing an electrical charge. Sometimes called a condenser.

Clipping. Distortion of a signal by its being chopped off. An overload problem caused by pushing an amplifier beyond its capabilities. The flat-topped signal has high levels of harmonic distortion which creates heat in a loudspeaker and is the major cause of loudspeaker component failure.

CLS. The abbreviation for curvilinear linesource.

Crossover. An electrical circuit that divides a full bandwidth signal into the desired frequency bands for the loudspeaker components.

dB (decibel). A numerical expression of the relative loudness of a sound. The difference in decibels between two sounds is ten times the Base 10 logarithm of the ratio of their power levels.

DC. Abbreviation for direct current.

Diffraction. The breaking up of a sound wave caused by some type of mechanical interference such as a cabinet edge, grill frame or other similar object.

Diaphragm. A thin flexible membrane or cone that vibrates in response to electrical signals to produce sound waves.

Distortion. Usually referred to in terms of total harmonic distortion (THD) which is the percentage of unwanted harmonics of the drive signal present with the wanted signal. Generally used to mean any unwanted change introduced by the device under question.

Driver. See transducer.

Dynamic Range. The range between the quietest and the loudest sounds a device can handle (often quoted in dB).

Efficiency. The acoustic power delivered for a given electrical input. Often expressed as decibels/watt/meter (dB/w/m).

ESL. The abbreviation for electrostatic loudspeaker.

Headroom. The difference, in decibels, between the peak and RMS levels in program material.

Hybrid. A product created by the marriage of two different technologies. Meant here as the combination of a dynamic woofer with an electrostatic transducer.

Hz (Hertz). Unit of frequency equivalent to the number of cycles per second.

Imaging. To make a representation or imitation of the original sonic event.

Impedance. The total opposition offered by an electric circuit to the flow of an alternating current of a single frequency. It is a combination of resistance and reactance and is measured in ohms. Remember that a speaker's impedance changes with frequency, it is not a constant value.

Inductance. The property of an electrical circuit by which a varying current in it produces a varying magnetic field that introduces voltages in the same circuit or in a nearby circuit. It is measured in henrys.

Inductor. A device designed primarily to introduce inductance into an electrical circuit. Sometimes called a choke or coil.

Linearity. The extent to which any signal handling process is accomplished without amplitude distortion.

Midrange. The middle frequencies where the ear is the most sensitive.

Passive crossover. Uses no active components (transistors, IC's, tubes) and needs no power supply (AC, DC, battery) to operate. The crossover in a typical loudspeaker is of the passive variety. Passive crossovers consist of capacitors, inductors and resistors.

Phase. The amount by which one sine wave leads or lags a second wave of the same frequency. The difference is described by the term phase angle. Sine waves in phase reinforce each other; those out of phase cancel.

Pink noise. A random noise used in measurements, as it has the same amount of energy in each octave.

Polarity. The condition of being positive or negative with respect to some reference point or object.

RMS. Abbreviation for root mean square. The effective value of a given waveform is its RMS value. Acoustic power is proportional to the square of the RMS sound pressure.

Resistance. That property of a conductor by which it opposes the flow of electric current, resulting in the generation of heat in the conducting material, usually expressed in ohms.

Resistor. A device used in a circuit to provide resistance.

Resonance. The effect produced when the natural vibration frequency of a body is greatly amplified by reinforcing vibrations at the same or nearly the same frequency from another body.

Sensitivity. The volume of sound delivered for a given electrical input.

Stator. The fixed part forming the reference for the moving diaphragm in a planar speaker.

THD. The abbreviation for total harmonic distortion. (See Distortion)

TIM. The abbreviation for transient intermodulation distortion.

Transducer. Any of various devices that transmit energy from one system to another, sometimes one that converts the energy in form. Loudspeaker transducers convert electrical energy into mechanical motion.

Transient. Applies to that which lasts or stays but a short time. A change from one steady-state condition to another.

Tweeter. A small drive unit designed to reproduce only high frequencies.

Wavelength. The distance measured in the direction of progression of a wave, from any given point characterized by the same phase.

White noise. A random noise used in measurements, as it has the same amount of energy at each frequency.

Woofers. A drive unit operating in the bass frequencies only. Drive units in two-way systems are not true woofers but are more accurately described as being mid/bass drivers.



WARNING! Do not use your Feature loudspeaker outside of the country of original sale—voltage requirements vary by country. Improper voltage can cause damage that will be potentially expensive to repair. The Feature is shipped to authorized MartinLogan distributors with the correct power supply for use in the country of intended sale. A list of authorized distributors can be accessed at www.martinlogan.com or by emailing info@martinlogan.com.



Lawrence, Kansas, USA tel 785.749.0133 fax 785.749.5320 www.martinlogan.com