

FRESCO™

u s e r ' s m a n u a l



MARTIN LOGAN®

the loudspeaker technology company

CONTENTS AND INTRODUCTION

Contents

Contents and Introduction	2
Contents	
Introduction	
Installation in Brief	3
Operation	4
Signal Connection	
On Wall/Off Wall Switch	
Break-In	
Mounting the Fresco On A Wall or Ceiling	5
Which Way Should It Rotate?	
Preparing For Vertical Installation	6
Preparing For Horizontal Installation	
Changing the Direction of Rotation	7
Installing the Bracket Assembly	8
Installing the Fresco	9
Home Theater	13
ATF (Advanced Thin Film)	14
Frequently Asked Questions and Troubleshooting .	16
General Information	17
Specifications	
Warranty and Registration	
Service	
Glossary of Audio Terms	18

Introduction

Congratulations! You have invested in a new world of home cinema!

The MartinLogan Fresco represents the culmination of an intensive, dedicated group research program directed toward establishing a world class reference monitor utilizing leading-edge technology, without compromising durability, reliability, craftsmanship or aesthetic design.

The advantages of MartinLogan ATF (advanced thin film) technology will present themselves to you from the moment the movie begins. The box effect (a phenomenon similar to cupping your hand around your mouth when speaking) produced by dynamic midrange drivers is absent and the natural openness of the human voice comes through. Sounds float around the screen clearly defining the area from where they were created, not the area of the speaker that created them.

The materials in your new Fresco speaker are of the highest quality and will provide years of enduring enjoyment and deepening respect. The cabinetry is constructed from the highest quality HIPP (high-impact polypropylene) to create an acoustically inert, high-density enclosure.

This User's Manual will explain in detail the operation of your Fresco speaker and the philosophy applied to their design. A clear understanding of your speakers will insure that you obtain maximum performance and pleasure from this most exacting transducer. It has been designed and constructed to give you years of trouble-free listening enjoyment.

INSTALLATION IN BRIEF

We know you are eager to hear your new Fresco loudspeaker, so this section is provided to allow fast and easy set up. Once you have it operational, please take the time to read, in depth, the rest of the information in this manual. It will give you perspective on how to attain the greatest possible performance from this most exacting transducer.

If you should experience any difficulties in the setup or operation of your Fresco speaker, please refer to the Operation or Mounting sections of this manual.

Should you encounter a persistent problem that cannot be resolved, please contact your authorized MartinLogan dealer. They will provide you with the appropriate technical analysis to alleviate the situation.



WARNING!

- Refer servicing to a qualified technician.
- To prevent fire or shock hazard, do not expose this module to moisture.
- Turn amplifier off should any abnormal conditions occur.
- Do not drive speaker beyond its rated power.



The lightning bolt flash with arrowhead symbol within an equilateral triangle is intended to alert the user to the presence of uninsulated “dangerous voltage” within the product’s enclosure that may be of sufficient magnitude to constitute a risk of electric shock.



The exclamation point within an equilateral triangle is intended to alert the user to the presence of important operating and maintenance (servicing) instructions in the literature accompanying the appliance.

Step 1: Unpacking

Remove your new Fresco speaker from the packing.

Step 2: Placement

Place the Fresco near the desired location. Please see the ‘Mounting the Fresco On a Wall or Ceiling’ section (page 5–12) for more placement details.

Step 3: Signal Connection

Use the best speaker cables you can. Higher quality cables, available from your specialty dealer, are recommended and will give you superior performance. Spade connectors are suggested for optimum contact and ease of installation.

Attach your speaker cables to the signal input section on the rear panel. Be consistent when connecting speaker leads to the terminals on the back of the Fresco. Take great care to assign the same color to the (+) terminal on both the speaker and the amplifier. Please see the ‘Operation’ section (page 4) for more details.

Step 4: Listen and Enjoy

Now, you may turn on your system and enjoy!

OPERATION

Signal Connection

Use the best speaker cables you can. The length and type of speaker cable used in your system will have an audible effect. Under no circumstance should a wire of gauge higher (thinner) than #16 be used. In general, the longer the length used, the greater the necessity of a lower gauge, and the lower the gauge, the better the sound, with diminishing returns setting in around #8 to #12.

A variety of speaker cables are now available whose manufacturers claim better performance than standard heavy gauge wire. We have verified this in many cases, and the improvements available are often more noticeable than the differences between wires of different gauge. The effects of cables may be masked if the equipment is not of the highest quality.

We also recommend, if possible, that short runs of speaker cable connect the power amplifier and speaker and that high quality long interconnect cables be used to connect the preamplifier and power amplifier. This results in the power amplifiers being close to the speakers, which may be practically or cosmetically difficult, but if the length of the speaker cables can be reduced to a few meters, sonic advantages may be obtained.

Connections are done at the signal input section on the rear electronics panel of the Fresco (see figure 1). Use spade connectors for optimum contact. Make certain that all of your connections are tight.

Be consistent when connecting speaker leads to the terminals on the back of the Fresco. Take great care to assign the same color to the (+) terminal on both the speaker and the amplifier.

 **WARNING!** Turn your amplifier off before making or breaking any signal connections!

On Wall/Off Wall Switch

Fresco features a unique 'on-wall/off-wall' switch that tailors Fresco's acoustic equalization to either installation option. Simply set this switch to On Wall if the Fresco is mounted to a wall or ceiling. Set the switch to Off Wall if the Fresco is more than four inches from a wall (see figure 1).

Break-In

When you first begin to play your Fresco speaker, it will sound a bit bass shy. This is due to the high-quality, long-life components used in our woofer. Our custom made woofers require at least 30 hours of break-in at 90 dB (moderate listening levels) before any critical listening. The break-in requirements of the crossover components (and, to a lesser degree, the ATF transducer) are equal.

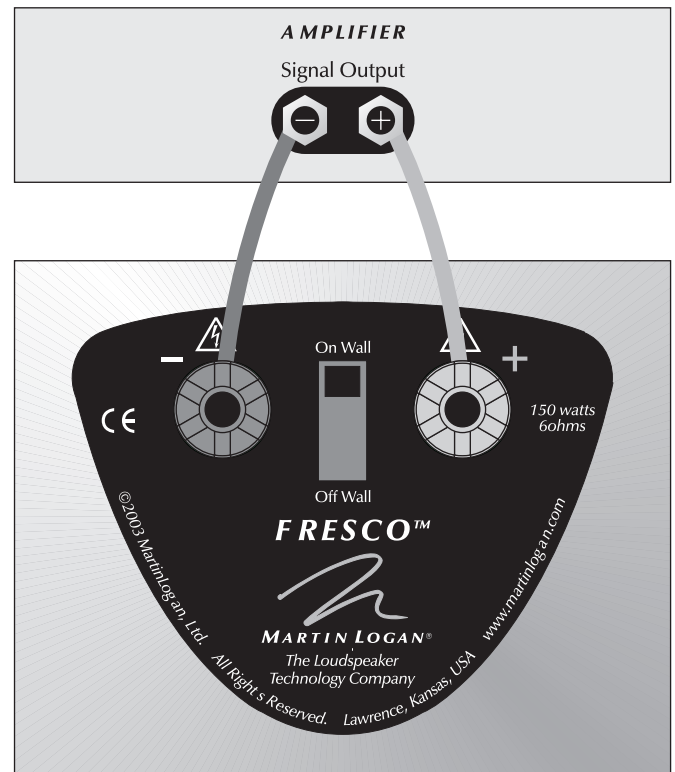

Figure 1. Single wire connection. One channel shown.

MOUNTING THE FRESCO ON A WALL OR CEILING

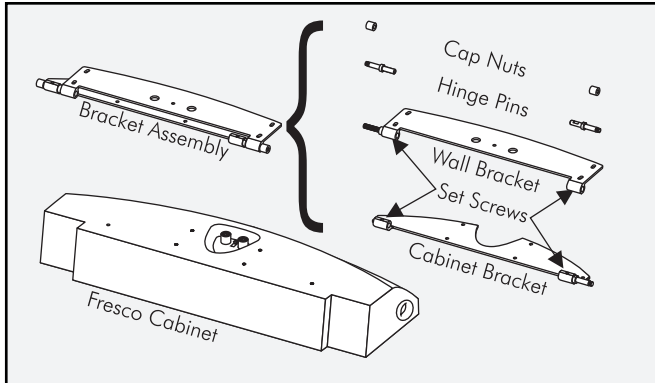

Figure 2. The parts of the Fresco bracket assembly.

NOTE: MartinLogan recommends using 5 wall anchors to secure each Fresco to a wall. During the installation, if any of the screw/wall anchor positions are over a stud, it is recommended to screw directly into the stud.

NOTE: To assure that your Fresco is safely wall mounted, these instructions must be carefully followed. Study them thoroughly before installing your Fresco's.

NOTE: The following instructions assume the mounting surface is of standard wood frame and standard sheet rock construction. If you wish to mount the Fresco to another type of material, you should consult a bonded contractor.



WARNING! Installing the Fresco on a wall requires only 1 person, but an assistant will be helpful.

The bracket assembly shipped with the Fresco loudspeaker is designed for use only with the Fresco. Use with other appliances may result in instability causing possible injury. To prevent injury, this apparatus must be securely attached to the wall in accordance with the installation instructions.

Which Way Should It Rotate?

The bracket assembly supplied with the Fresco allows the speaker to mount flat against a wall and pivot up to 90°. Depending on the installation locations, the Fresco on-wall bracket will need to be modified to allow either right/up or left/down rotation (see figure 3 and 4). The configuration of Fresco's bracket assembly is identical for right and up rotation and is identical for left and down rotation.

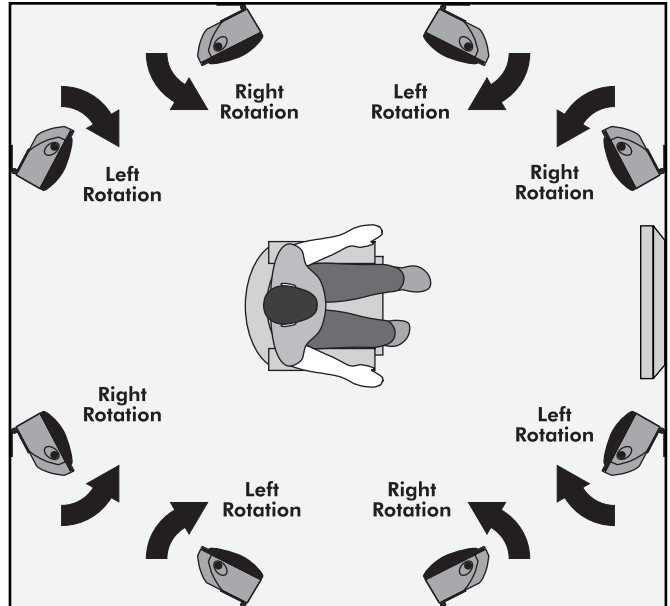

Figure 3. Vertical Installation. Rotation direction for various installation locations.

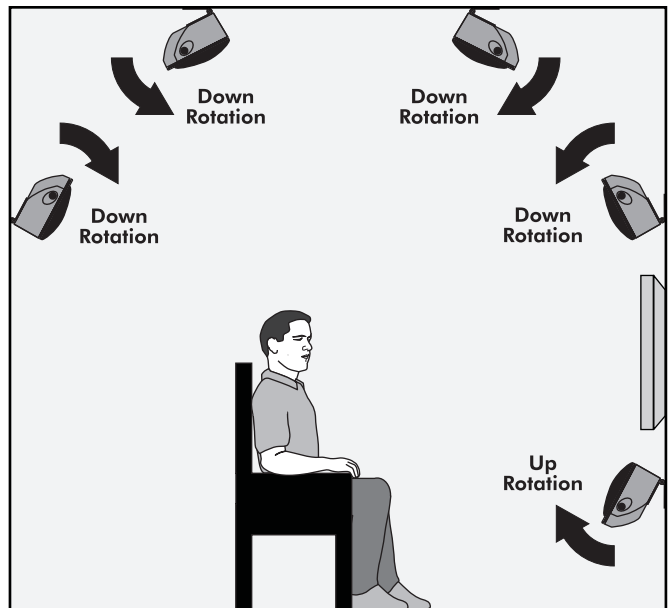

Figure 4. Horizontal Installation. Rotation direction for various installation locations.

INSTALLATION

Preparing For Vertical Installation

NOTE: Fresco’s bracket assembly consists of two main parts: the wall bracket (attaches to the wall) and the cabinet bracket (attaches to the Fresco). When correctly configured the wall and cabinet brackets should each have one pin installed—the wall bracket with an upward pointing pin in the upper hinge, and the cabinet bracket with a downward pointing pin in the lower hinge (see figures 5 and 6).

NOTE: When correctly installed in a vertical orientation, the Fresco’s cabinet bracket (installed on the cabinet) should slide down, onto the wall bracket (installed on the wall).

Each Fresco should be installed so that it can rotate to point towards your listening position (see figure 3). Hold each Fresco near its desired location and try pivoting it to assure that each speaker is correctly configured.

Preparing for Horizontal Installation

NOTE: Fresco’s bracket assembly consists of two main parts: the wall bracket (attaches to the wall) and the cabinet bracket (attaches to the Fresco). When correctly configured each bracket should have one pin installed—the wall bracket with a pin installed in the left hinge, pointing to the left and the cabinet bracket with a pin installed in the right hinge, pointing to the right (see figures 5 and 6).

NOTE: When the Fresco is correctly installed in a horizontal orientation, gravity will pull on the speaker trying to rotate down. The Fresco bracket assembly is designed in such a way that the force of gravity will tighten the left cap nut and prevent the speaker from rotating.

Each Fresco should be installed so that it can rotate to point towards your listening position (see figure 4). Hold each Fresco near its desired location and try pivoting it to assure that each speaker is correctly configured.

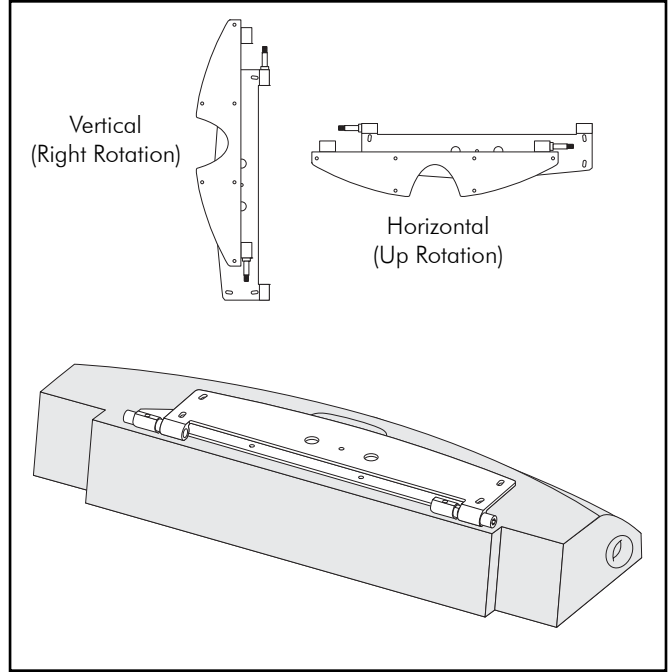

Figure 5. Fresco’s bracket assembly configured for right/up rotation

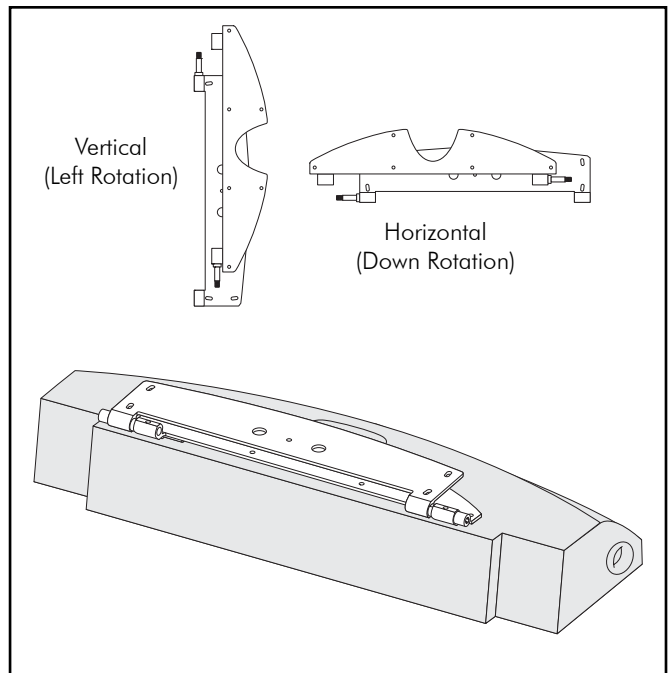

Figure 6. Fresco’s bracket assembly configured for left/down rotation

Changing the Direction of Rotation

Required tools (included):

2.5mm Allen tool, 6mm Allen tool

NOTE: This procedure can be performed either with the bracket assembly installed on the Fresco cabinet or with the bracket assembly uninstalled. For the purpose of illustrating this procedure, the bracket assembly is depicted installed on a cabinet.

- 1 Ignore this step if the bracket assembly is not installed on the Fresco. Prepare a flat surface with padding and sheets to protect the speaker as you work on it. Remove the Fresco's grill cover and carefully place the Fresco face down on the work surface, using books or pieces of cardboard to keep the speaker from rocking.
- 2 Using the 6mm Allen tool, remove the 2 cap nuts and washers from the hinges. Place them aside (see figure 7).
- 3 Carefully remove the wall bracket from the cabinet bracket (see figure 8).
- 4 Using the 2.5mm Allen tool, carefully remove the 2 set screws that hold the 2 hinge pins in place (see figure 9).
- 5 Move the wall bracket hinge pin to the outside of the opposite hinge. Move the cabinet bracket hinge pin to the outside of the opposite hinge (see figure 10).
- 6 Using the 2.5mm Allen tool, reinstall the 2 set screws to lock the hinge pins in place. Make sure the set screw tightens against the flat surface of the pin (see figure 11).
- 7 Reinstall the washers and cap nuts.

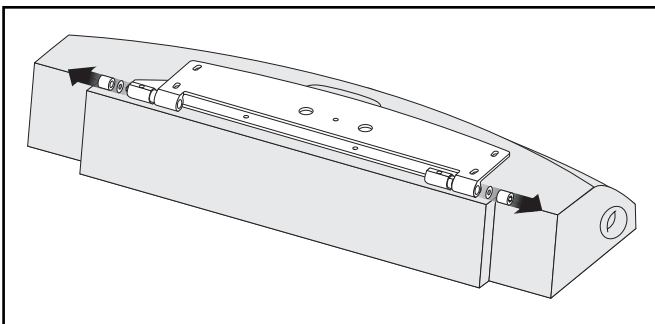

Figure 7. Remove the 2 cap nuts and washers from the hinges.

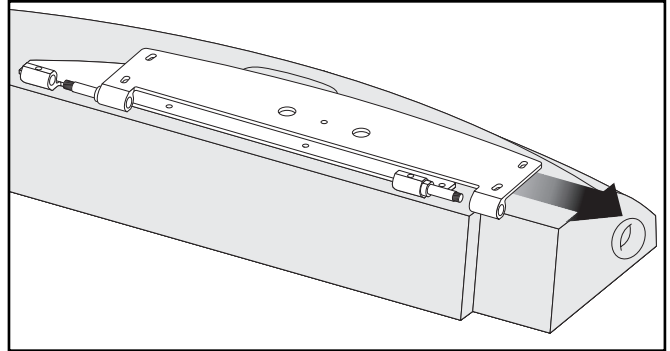

Figure 8. Remove the wall bracket from the cabinet bracket.

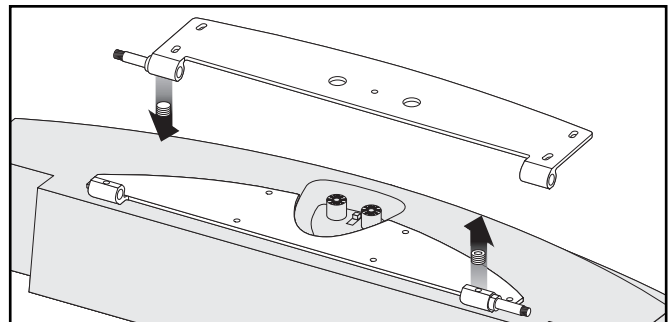

Figure 9. Remove the 2 set screws.

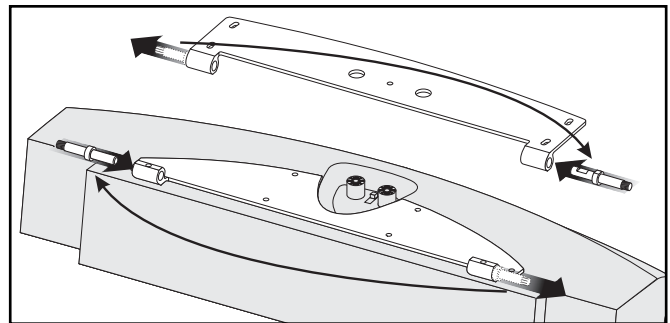

Figure 10. Change hinge pin locations.

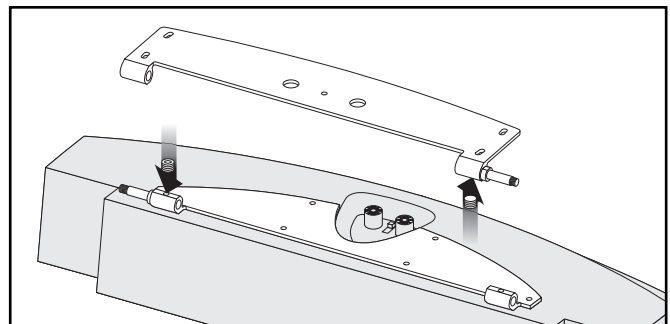

Figure 11. Reinstall the two set screws to hold hinge pins in place.

Installing the Bracket Assembly

Required hardware (included):

(6) M4 screws

Required tools (included):

2.5mm Allen tool

- 1 Prepare a flat surface with padding and sheets to protect the speaker as you work on it. Remove the Fresco's grill cloth and carefully place the Fresco face down on the work surface, using books or pieces of cardboard to keep the speaker from rocking.
- 2 Using the 6mm Allen tool, loosen the 2 cap nuts (see figure 12).
- 3 Rotate/open the wall bracket away from the cabinet bracket (see figure 13).
- 4 Align the 6 holes in the Fresco's wall mounting bracket with the holes on the back of the Fresco's cabinet. Please note that the wall bracket should lie flat against the Fresco cabinet with the hinges along the flat, straight edge of the cabinet (see figure 14).
- 5 Using the 2.5MM Allen tool, install the 6 screws that attach the cabinet bracket and firmly tighten them (see figure 15).

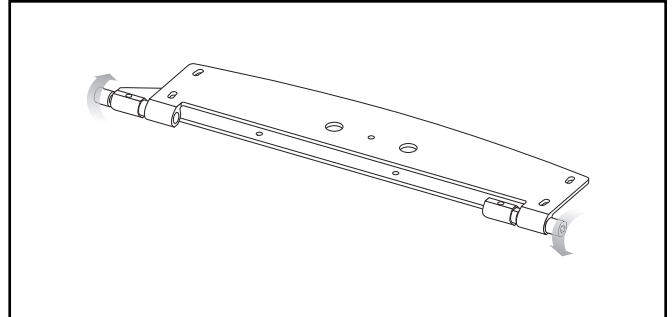

Figure 12. Loosen the 2 cap nuts.

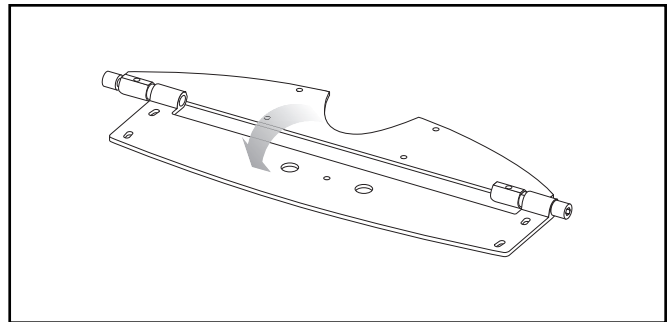

Figure 13. Rotate/open the wall bracket away from the cabinet bracket.

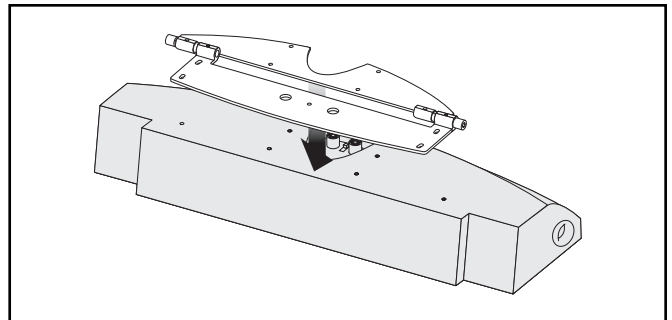

Figure 14. Align the 6 holes on the mounting bracket with those of the Fresco.

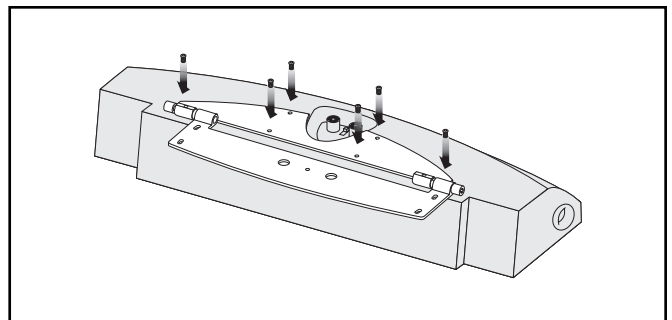

Figure 15. Install 6 screws.

Installing the Fresco

Required hardware (included):

- (5) wall anchors
- (5) 1" Phillips head wood screws

Required tools (included):

- 6mm Allen tool

Required tools (not included):

- Level
- Electric drill and 1/4" and 1/8" drill bits
- Phillips screwdriver

- 1 Hold the Fresco at the desired location. Examine the mounting location to assure that the wall is free of obstructions.

Test the direction of rotation to assure that the speaker can rotate toward your listening position. If the speaker rotates away from your listening position, please refer to 'Which Direction Should It Rotate?' (page 5) and 'Changing the Direction of Rotation' (page 7).

- 2 **NOTE:** These instructions describe the position of the wall bracket with the Fresco mounted flush against a wall (not rotated on its bracket).

NOTE: The center point of the wall-bracket is not the same as the center of the Fresco. These directions describe the location of the center of the wall-bracket, which you will need to know in order to mount the speaker at your desired location.

Determine where the center point of the wall bracket should be marked (see figures 16 and 17).

Will the Fresco remain flat against the wall? If so, it can be installed flush against an object such as a plasma screen (see figure 18).

Will the Fresco be rotated to point towards the listening position? If so you need to leave space between the nearest object to allow clearance for the speaker to pivot (see figure 18). At least 6.75" (17.2cm) of clearance will allow the Fresco to pivot within its full range of motion. Less space is needed if the Fresco does not need to fully rotate. As recommended above, before drilling any holes, hold the Fresco at its desired location and rotate it into place to assure you have adequate clearance.

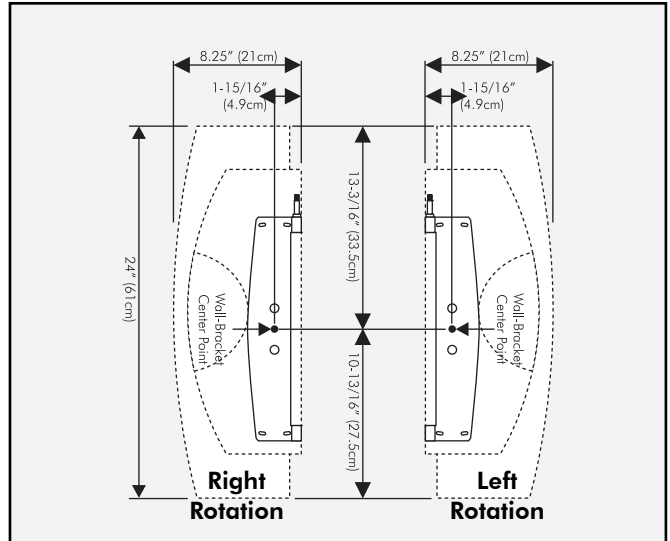

Figure 16. Determining the wall brackets center point in a vertical installation.

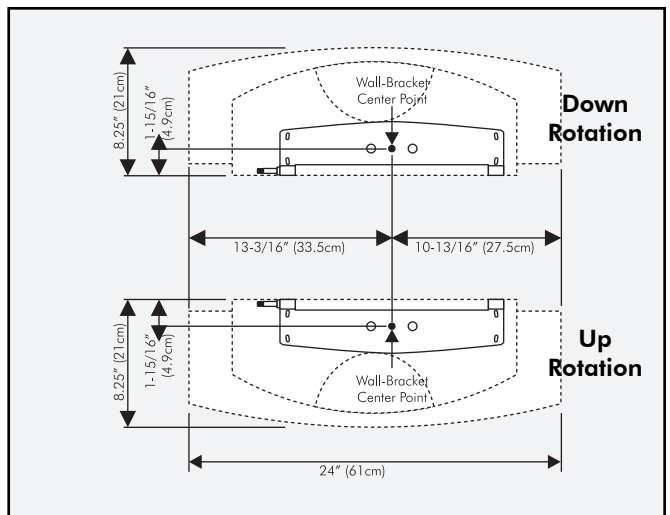

Figure 17. Determining the wall brackets center point in a horizontal installation.

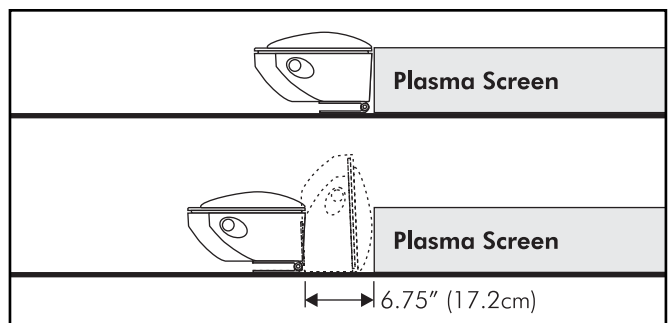

Figure 18. Clearance requirements to allow rotation of the Fresco.

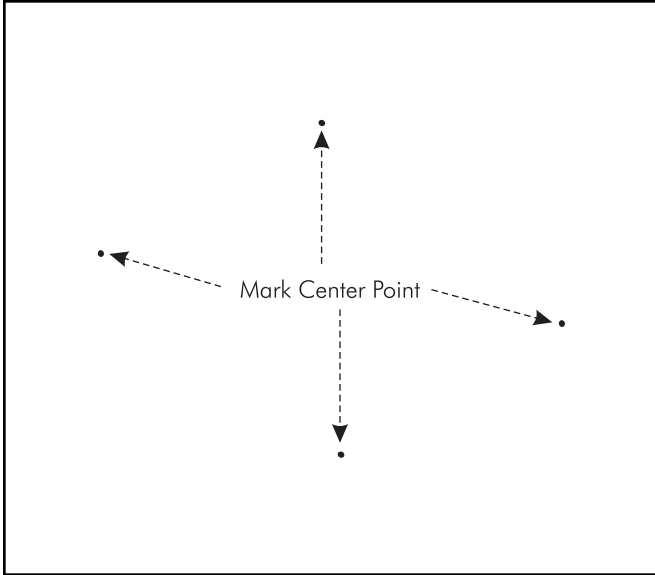

Figure 19. Mark the center points.

NOTE: Figures 19–24 illustrate the Fresco mounted in 4 different configurations.

- 3 Mark your wall with the center point for the wall bracket (see figure 19).

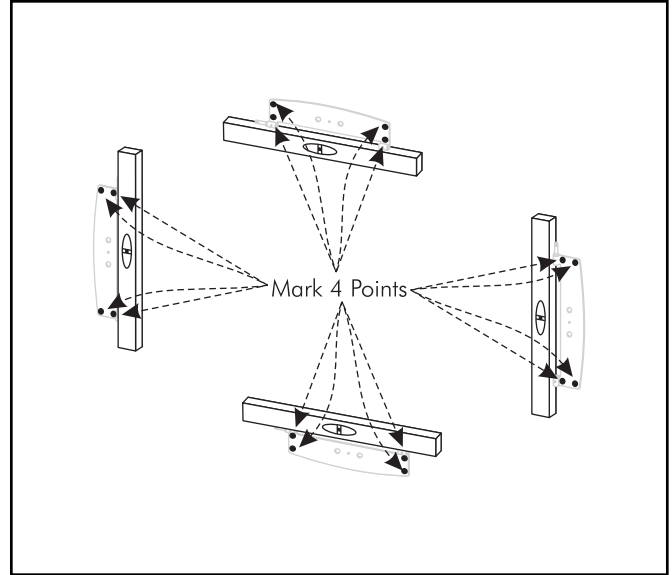

Figure 20. Use a level to square the wall bracket and mark the other 4 holes.

- 4 Using a level, square the wall bracket and hold it flush against the wall with the wall bracket's center hole over the point you just marked. The cylindrical hinges on the wall bracket should point away from the wall and the flat plane of the wall bracket should be flush against the wall. Mark 4 points inside of the wall bracket's arc shaped cut outs located at either end of the wall bracket (see figure 20).

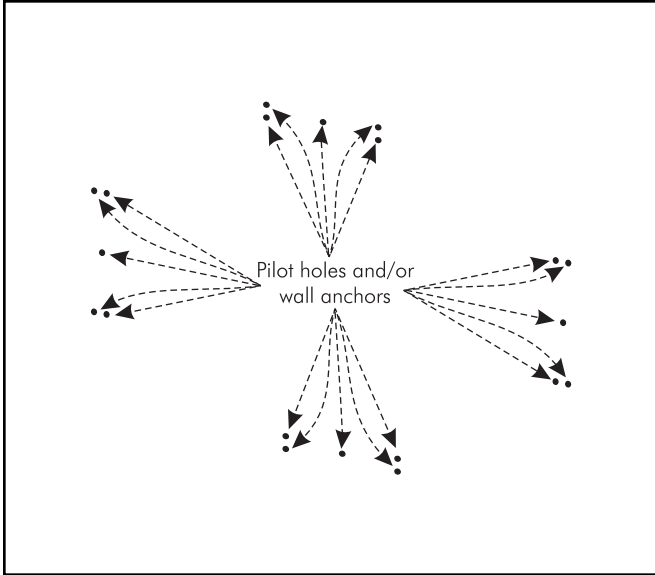

Figure 21. Drill pilot holes and/or sink wall anchors at the 5 marked locations.

- 5 Set the wall bracket aside. Using a 1/8" bit, drill a pilot hole at all five points marked in the previous steps.

If a pilot hole *hits a stud* during this step, **DO NOT WIDEN** that pilot hole or install a wall anchor at that location.

If a pilot hole *does not hit a stud*, use a 1/4" bit to widen that pilot hole and using a Phillips screwdriver install a wall anchor so that it is flush with the wall (see figure 21).

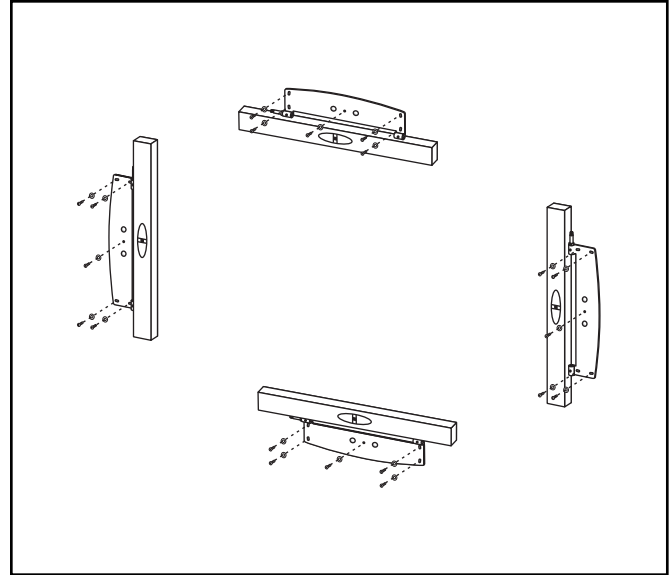

Figure 22. Using a level, square the wall bracket and install the screws.

- 6 Mount the wall bracket to the center wall anchor (or pilot hole) using a 1" Phillips head screw driven through the wall brackets center point. Do not fully tighten the screw—the bracket must be leveled before installing the remaining screws (see figure 22).
- 7 Using a level, square the bracket and drive the four remaining 1" Phillips head screws into the wall anchors (or pilot holes). Do not fully tighten the screws (see figure 22).
- 8 Using a level, make sure the bracket is level and tighten all five screws (see figure 22).

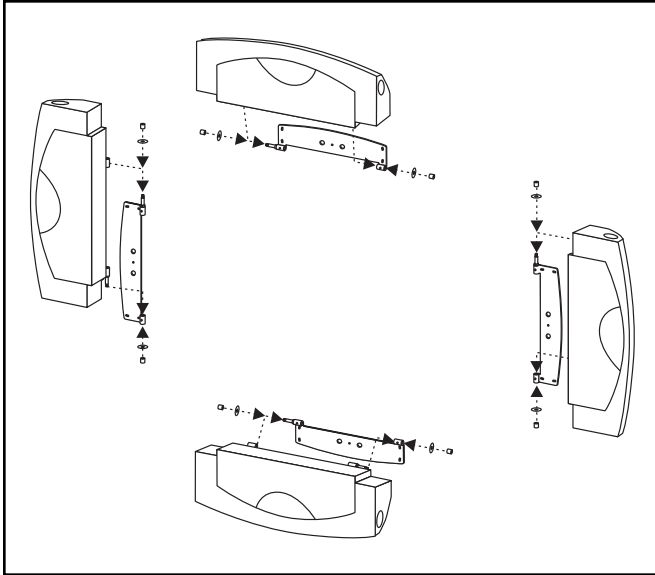

Figure 23. Install the Fresco and the washers and cap nuts.

- 9 Place the Fresco onto the wall bracket and carefully slide the Fresco into place (see figure 23).
- 10 Using a 6mm Allen tool, attach a washer and cap nut onto each pin. Do not fully tighten the cap nuts (see figure 23).
- 11 Make the signal connections from the amplifier (see 'Operation', pages 4).

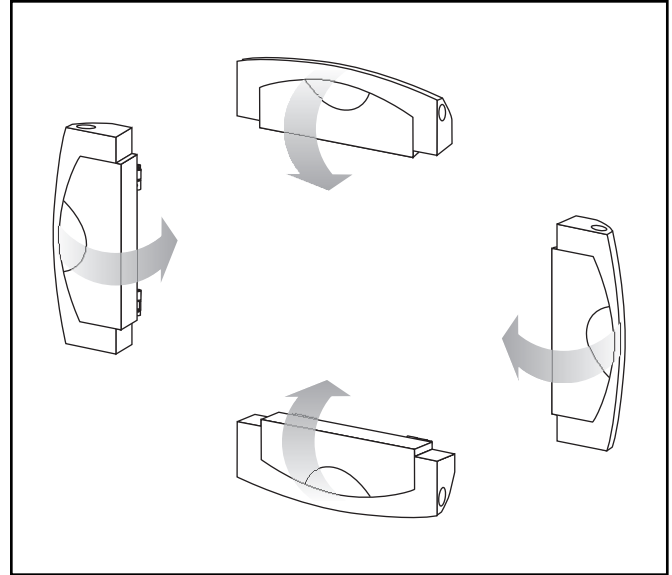

Figure 24. Rotate the Fresco into position and tighten the cap nuts.

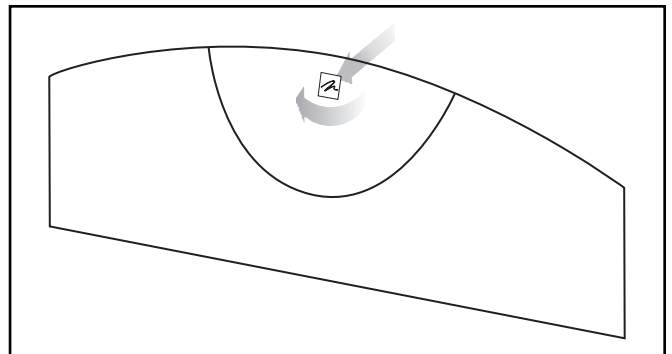

Figure 25. Rotate the Fresco's logo medallion so it is correctly orientated.

- 12 Rotate the Fresco to point at the listening position and tighten the cap nuts (see figure 24).
- 13 Rotate the Fresco's logo medallion, by removing the grill cloth cover, gently pressing the medallion from behind and turning it to the correct orientation (see figure 25).

It had long been the practice of stereo buffs to connect their television to a stereo system. The advantage was the use of the larger speakers and more powerful amplifier of the stereo system. Even though the sound was greatly improved, it was still mono and limited by the broadcast signal.

In the late 1970's and early 1980's two new home movie formats became widely available to the public: VCR and laser disc.

By 1985, both formats had developed into very high quality audio/video sources. In fact, the sonic performance of some video formats exceeded audio-only formats. Now, with theater-quality sound available at home, the only element missing was the "surround sound" presentation found in movie houses.

Fortunately, Dolby and DTS-encoded movies (which include almost all movies) have the same surround sound information encoded on home releases as the theater films. All that is required to retrieve this information is a decoder and additional speakers and amps to reproduce it.

Home theater is a complex purchase and we recommend that you consult your local MartinLogan dealer, as they are well versed in this subject.

Each piece of a surround system can be purchased separately. Take your time and buy quality. No one has ever complained that the movie was too real. The following list and descriptions will give you only a brief outline of the responsibilities and demands placed on each speaker.

Front Left and Front Right

If these speakers will be the same two used for your stereo playback, they should be of very high quality and able to play loudly (over 102 dB) and reproduce bass below 80 Hz.

Center Channel

This is the most important speaker in a video system, as almost all of the dialogue and a large portion of the front speaker information is reproduced by the center channel. It is important that the center speaker be designed by the same manufacturer as the front speakers, and that it is recommended for use as a center speaker. This is not the place to cut corners.

Surround Speakers

We recommend that the surround speakers play down to 80 Hz or below. The surround speakers contain the information that makes it appear that planes are flying over your head. Some may suggest that this is the place to save money and purchase a small, inexpensive speaker. If you choose to do so, be prepared to upgrade in the future as discrete six-channel digital encoding becomes available and the demands on the surround speakers increase.

Subwoofer

With any good surround system you will need a high-quality subwoofer (the .1 in a 5.1 channel surround system). Most movie soundtracks contain large amounts of bass information as part of the special effects. Good subwoofers will provide a foundation for the rest of the system.

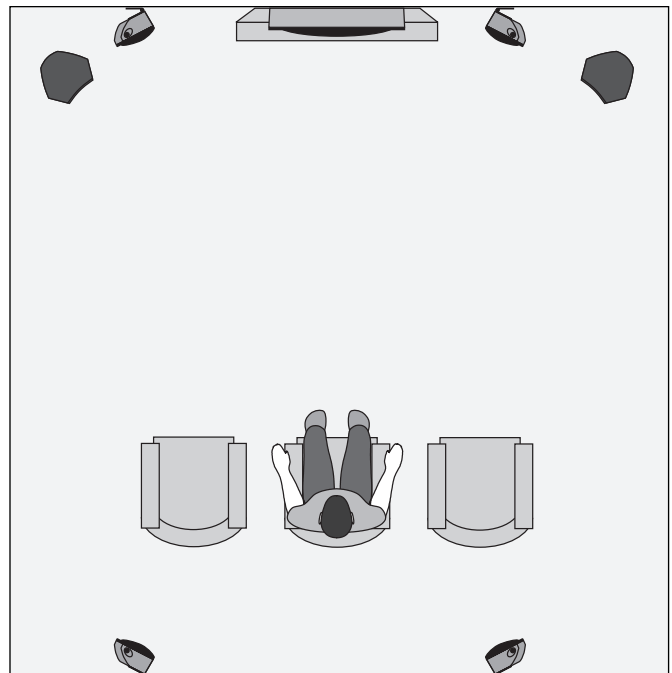

Figure 26. Fresco loudspeakers as front, center and surround (effects) channels. Grotto subwoofers as 0.1 (effects) channel.

ATF (ADVANCED THIN FILM)

ATF Operation

The MartinLogan ATF transducer (based on RADIA planar technology) consists of a micro-thin, low-mass Kaladex diaphragm with an ultra-light, etched conductive aluminum surface suspended between two high field strength neodymium super magnet arrays (see figure 27). When an electrical current (music signal) passes through the etched aluminum on the diaphragm's surface it is simultaneously pulled towards one of the neodymium arrays and pushed away from the opposing array. When the direction of current is reversed the diaphragm is simultaneously pushed and pulled in the opposite direction, thus producing sound.

Extremely Low-Mass Diaphragm

—Blazing Speed and Inner Detail

Low-mass diaphragms are crucial to a loudspeakers ability to accurately reproduce sound. As the mass of a transducer's diaphragm decreases, its ability to resolve detail increases. With extremely low-mass characteristics, the ATF transducer tracks the audio signal with almost perfect accuracy.

MartinLogan ATF diaphragms are constructed of extremely low mass Dupont Kaladex® PEN (polyethylene naphthalate) —a material chemically similar to the low-mass PET (polyethylene terephthalate) film used in MartinLogan's generation 2 electrostatic transducers, yet capable of handling the high thermal requirements required for stable magnetic thin film operation.

High Field Strength

—Superb Control and Efficiency

With a field strength almost 2000% more powerful than traditional systems, Neodymium iron boron (NIB) rare-earth super magnets are one of the world's strongest commercially available magnetic materials. This incredible field strength proves ideal for maintaining perfect control over the low-mass Kaladex diaphragm. Super-low distortion levels, high-resolution, and crystal-clear transparency are just a few of the benefits resulting from this superb combination of low-mass diaphragm and high field strength.

Push-Pull Operation = Ideal Linearity

Linearity is another factor contributing to a loudspeaker's ability to achieve ultimate clarity, detail and resolution. By positioning neodymium magnet arrays in a push-pull configuration, MartinLogan ATF transducer technology maintains uniform diaphragm control, regardless of position as it traverses the entire audio signal. The push-pull concept is a major contributor to the linearity and sonic superiority of ATF transducers.

Direct Full-Surface Drive Provides Outstanding Clarity

Unlike traditional voice coil driven systems, ATF diaphragms are directly and uniformly driven throughout their entire surface. This full-surface drive system results in ultra-fast transient response with no cone break up and the ability to accurately reproduce sound with great delicacy, nuance and clarity.

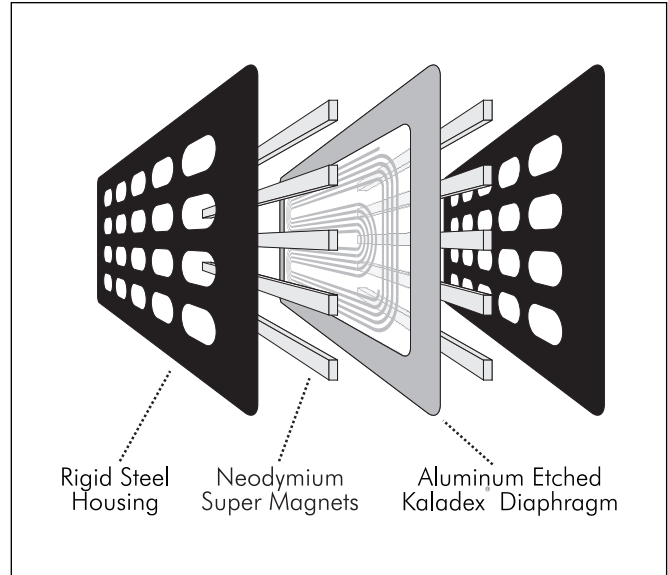

Figure 27. Cut away view of an ATF transducer. Note the simplicity due to minimal parts usage.

FREQUENTLY ASKED QUESTIONS AND TROUBLESHOOTING

Frequently Asked Questions

How do I clean my speakers?

Just use a dust free cloth or a soft brush to remove the dust from your speakers. We recommend a specialty cloth (available at the Xtatic shop at www.martinlogan.com) that cleans your speakers better than anything else we have tried. **Do not spray any kind of cleaning agent on or in close proximity to the ATF element.**

What size amplifier should I use?

We recommend an amplifier with 100 watts per channel for most applications. Probably less would be adequate when used in home theater where a subwoofer is employed. Our hybrid designs will perform well with either a tube or transistorized amplifier, and will reveal the sonic character of either type. However, it is important that the amplifier be stable operating into varying impedance loads: a stable amplifier will be able to deliver twice its rated wattage into 4 Ohms and should again double into 2 Ohms.

Could you suggest a list of suitable electronics and cables that would be ideal for MartinLogan speakers?

The area of electronics and cable choice is probably the most common type of question that we receive. It is also the most subjective. We have repeatedly found that brands that work well in one setup will drive someone else nuts in another. We use many brands with great success. Again, we have no favorites; we use electronics and cables quite interchangeably. We would suggest listening to a number of brands—and above all else—trust your ears. Dealers are always the best source for information when purchasing additional audio equipment.

Is there likely to be any interaction between my speakers and the television in my Audio/Video system?

The MartinLogan Fresco loudspeaker is fully shielded and can go anywhere.

Will exposure to sunlight affect the life or performance of my speakers?

We recommend that you not place any loudspeaker in direct sunlight. The ultraviolet (UV) rays from the sun can cause deterioration of grill cloth, speaker cones, etc. Small exposures to UV will not cause a problem. In general, the filtering of UV rays through glass will greatly reduce the negative effects.

Troubleshooting

Output

- Check that all your system components are turned on.
- Check your speaker wires and connections.
- Check all interconnecting cables.

Specifications

System Frequency Response

75–20,000 Hz \pm 3 dB

Sensitivity

90 dB/2.83 volts/meter

Impedance

5 ohms

Crossover Frequency

500, 3200 Hz

Components

Air core coils, metal film and low dissipation electrolytic capacitors

Woofers Type

Two 4" (10.2cm) magnetically shielded high rigidity aluminum cone with extended throw drive assembly, non-resonance asymmetrical chamber format; bass reflex

ATF Mid-Range Driver

1.5" x 6" (3.8cm x 15.2cm) ATF Transducer

ATF High Frequency Driver

1.5" x 2.25" (3.8cm x 5.7cm) ATF Transducer

Power Handling

150 watts rms

Weight

16 lbs. each (7.3 kg)

Size Without Stand

24" inches W \times 4.9375" inches D \times 8.25" inches H
(61cm W \times 12.54cm D \times 21.6cm H)

Size With Stand

24" inches W \times 5.6875" inches D \times 8.25" inches H
(61cm W \times 14.45cm D \times 21.6cm H)

Warranty and Registration

Your Fresco speaker is provided with an automatic Limited 90 Day Warranty coverage.

You have the option, at no additional charge, to receive a Limited 5 Year Warranty coverage. To obtain the Limited 5 Year Warranty coverage you need to complete and return the Certificate of Registration, included with your speakers, and provide a copy of your dealer receipt, to MartinLogan within 30 days of purchase.

For your convenience MartinLogan also offers online warranty registration at www.martinlogan.com.

MartinLogan may not honor warranty service claims unless we have a completed Warranty Registration on file!

If you did not receive a Certificate of Registration with your new Fresco speaker, you cannot be assured of having received new units. If this is the case, please contact your authorized MartinLogan dealer.

Service

Should you be using your MartinLogan product in a country other than the one in which it was originally purchased, we ask that you note the following:

- 1 The appointed MartinLogan distributor for any given country is responsible for warranty servicing only on units distributed by or through it in that country in accordance with its applicable warranty.
- 2 Should a MartinLogan product require servicing in a country other than the one in which it was originally purchased, the end user may seek to have repairs performed by the nearest MartinLogan distributor, subject to that distributor's local servicing policies, but all cost of repairs (parts, labor, transportation) must be born by the owner of the MartinLogan product.
- 3 If, after owning your speakers for six months, you relocate to a country other than the one in which you purchased your speakers, your warranty may be transferable. Contact MartinLogan for details.

GLOSSARY OF AUDIO TERMS

AC. Abbreviation for alternating current.

Active crossover. Uses active devices (transistors, ICs, tubes) and some form of power supply to operate.

Amplitude. The extreme range of a signal. Usually measured from the average to the extreme.

Arc. The visible sparks generated by an electrical discharge.

ATF. The abbreviation for advanced thin film.

Bass. The lowest frequencies of sound.

Bi-Amplification. Uses an electronic crossover, or line-level passive crossover, and separate power amplifiers for the high and low frequency loudspeaker drivers.

Capacitance. That property of a capacitor which determines how much charge can be stored in it for a given potential difference between its terminals, measured in farads, by the ratio of the charge stored to the potential difference.

Capacitor. A device consisting of two or more conducting plates separated from one another by an insulating material and used for storing an electrical charge. Sometimes called a condenser.

Clipping. Distortion of a signal by its being chopped off. An overload problem caused by pushing an amplifier beyond its capabilities. The flat-topped signal has high levels of harmonic distortion which creates heat in a loudspeaker and is the major cause of loudspeaker component failure.

CLS. The abbreviation for curvilinear linesource.

Crossover. An electrical circuit that divides a full bandwidth signal into the desired frequency bands for the loudspeaker components.

dB (decibel). A numerical expression of the relative loudness of a sound. The difference in decibels between two sounds is ten times the Base 10 logarithm of the ratio of their power levels.

DC. Abbreviation for direct current.

Diffraction. The breaking up of a sound wave caused by some type of mechanical interference such as a cabinet edge, grill frame or other similar object.

Diaphragm. A thin flexible membrane or cone that vibrates in response to electrical signals to produce sound waves.

Distortion. Usually referred to in terms of total harmonic distortion (THD) which is the percentage of unwanted harmonics of the drive signal present with the wanted signal. Generally used to mean any unwanted change introduced by the device under question.

Driver. See transducer.

Dynamic Range. The range between the quietest and the loudest sounds a device can handle (often quoted in dB).

Efficiency. The acoustic power delivered for a given electrical input. Often expressed as decibels/watt/meter (dB/w/m).

ESL. The abbreviation for electrostatic loudspeaker.

Headroom. The difference, in decibels, between the peak and RMS levels in program material.

Hybrid. A product created by the marriage of two different technologies. Meant here as the combination of a dynamic woofer with an electrostatic or ATF transducer.

Hz (Hertz). Unit of frequency equivalent to the number of cycles per second.

Imaging. To make a representation or imitation of the original sonic event.

Impedance. The total opposition offered by an electric circuit to the flow of an alternating current of a single frequency. It is a combination of resistance and reactance and is measured in ohms. Remember that a speaker's impedance changes with frequency, it is not a constant value.

Inductance. The property of an electrical circuit by which a varying current in it produces a varying magnetic field that introduces voltages in the same circuit or in a nearby circuit. It is measured in henrys.

Inductor. A device designed primarily to introduce inductance into an electrical circuit. Sometimes called a choke or coil.

Linearity. The extent to which any signal handling process is accomplished without amplitude distortion.

Midrange. The middle frequencies where the ear is the most sensitive.

NAC. The abbreviation for natural ambience compensation.

Passive crossover. Uses no active components (transistors, ICs, tubes) and needs no power supply (AC, DC, battery) to operate. The crossover in a typical loudspeaker is of the passive variety. Passive crossovers consist of capacitors, inductors and resistors.

Phase. The amount by which one sine wave leads or lags a second wave of the same frequency. The difference is described by the term phase angle. Sine waves in phase reinforce each other; those out of phase cancel.

Pink noise. A random noise used in measurements, as it has the same amount of energy in each octave.

Polarity. The condition of being positive or negative with respect to some reference point or object.

RMS. Abbreviation for root mean square. The effective value of a given waveform is its RMS value. Acoustic power is proportional to the square of the RMS sound pressure.

Resistance. That property of a conductor by which it opposes the flow of electric current, resulting in the generation of heat in the conducting material, usually expressed in ohms.

Resistor. A device used in a circuit to provide resistance.

Resonance. The effect produced when the natural vibration frequency of a body is greatly amplified by reinforcing vibrations at the same or nearly the same frequency from another body.

Sensitivity. The volume of sound delivered for a given electrical input.

Stator. The fixed part forming the reference for the moving diaphragm in a planar speaker.

THD. The abbreviation for total harmonic distortion. (See Distortion)

TIM. The abbreviation for transient intermodulation distortion.

Transducer. Any of various devices that transmit energy from one system to another, sometimes one that converts the energy in form. Loudspeaker transducers convert electrical energy into mechanical motion.

Transient. Applies to that which lasts or stays but a short time. A change from one steady-state condition to another.

Tweeter. A small drive unit designed to reproduce only high frequencies.

Wavelength. The distance measured in the direction of progression of a wave, from any given point characterized by the same phase.

White noise. A random noise used in measurements, as it has the same amount of energy at each frequency.

Woofers. A drive unit operating in the bass frequencies only. Drive units in two-way systems are not true woofers but are more accurately described as being mid/bass drivers.



MARTIN LOGAN®

the loudspeaker technology company

2101 Delaware Street, Lawrence, Kansas 66046, USA tel 785.749.0133 fax 785.749.5320 www.martinlogan.com

©2004 MartinLogan. All rights reserved.

Rev. #101104